

**EXPLORATORY PROBLEM #1:
Light Patterns**

Because of your physics background, you have been asked to consult for the FBI on an industrial espionage investigation. A new invention has been stolen from a workroom, and the FBI is trying to determine the time of the crime. They have found several witnesses who were walking outside the building that evening, but their only recollections are of unusual light patterns on the side of the building opposite the workroom. These patterns were caused by light from the workroom coming through two holes in the window shade, a circular hole and a triangular hole. The room has several lights in it, including two long workbench bulbs. During the theft, the burglar hit one of the workbench lamps and broke the supporting wire, leaving it hanging straight down. Together with the other bulb, it forms a large “L” shape. Going outside, you see that the lamps do leave interesting patterns on the sidewalk. Your job is to determine, based on the light patterns the witnesses recall seeing, when the theft took place. You decide to model the crime scene in your lab using the equipment shown below.



What patterns of light are produced with different shaped holes and light sources?

EQUIPMENT

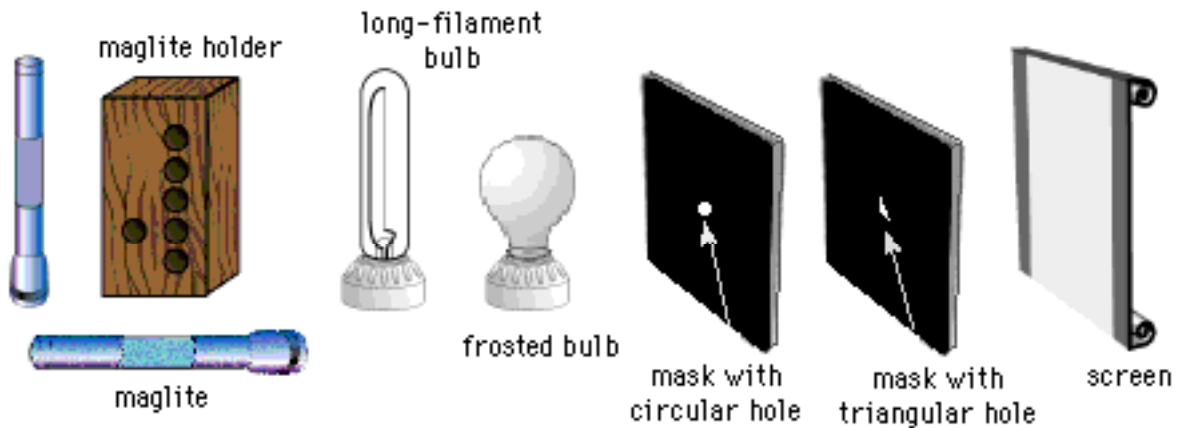

You will have: a maglite holder; two mini maglites; a clear tubular bulb with a straight filament mounted in a socket (representing a long workbench bulb); two cardboard masks, one with a circular hole and one with a triangular hole (representing the holes in the window shade); and a large white cardboard screen (representing the side of the building).

PREDICTIONS

1. Suppose you took a Maglite flashlight, took the cover off, and held it close to a card with a small circular hole in it. What would you see on the screen behind the card? Draw what you think you would see on the screen.

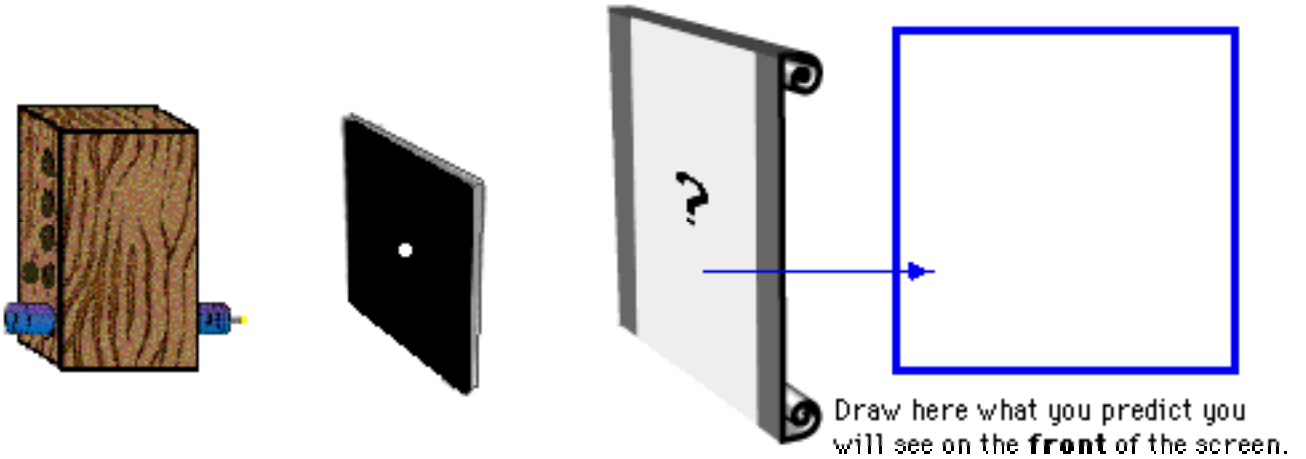

Explain your reasoning. Why do you think this is what you will see?

2. Now suppose you had a bulb with a long filament inside. Imagine you were to hold this near the card with a small circular hole in it. Draw what you predict you would see on the screen.

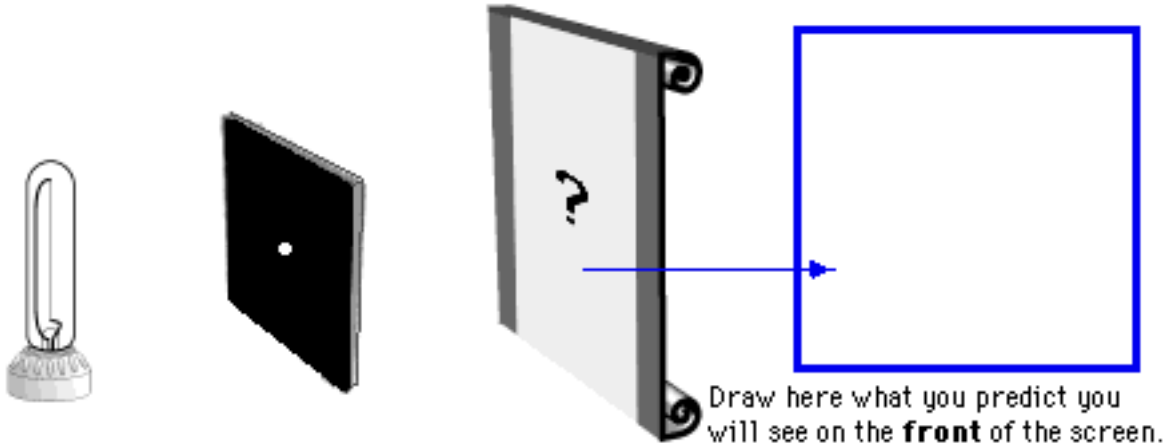

Why did you draw what you drew? Explain your reasoning.

3. Suppose you took two of the long filament bulbs and held them together to form an “L” shaped filament, and held this setup near a card with a small circular hole in it. What would you see on the screen? Draw your prediction.

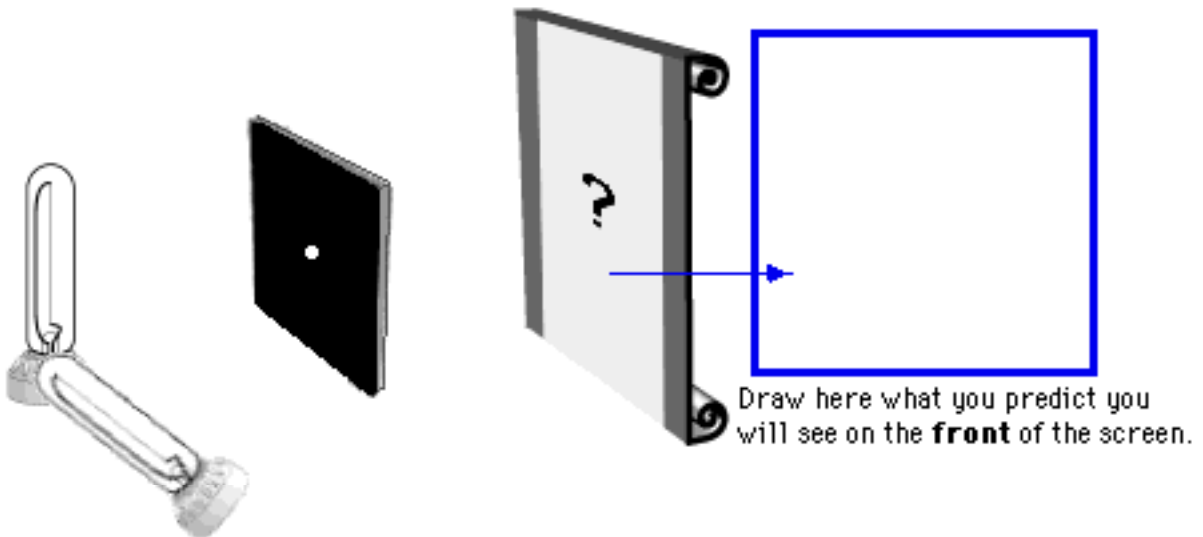

What was your reasoning?

4. Now imagine you kept the bulbs in the shape of an “L”, but now replace the hole in the card with a triangle instead of a circle. Predict what you would see on the screen, and draw your prediction.

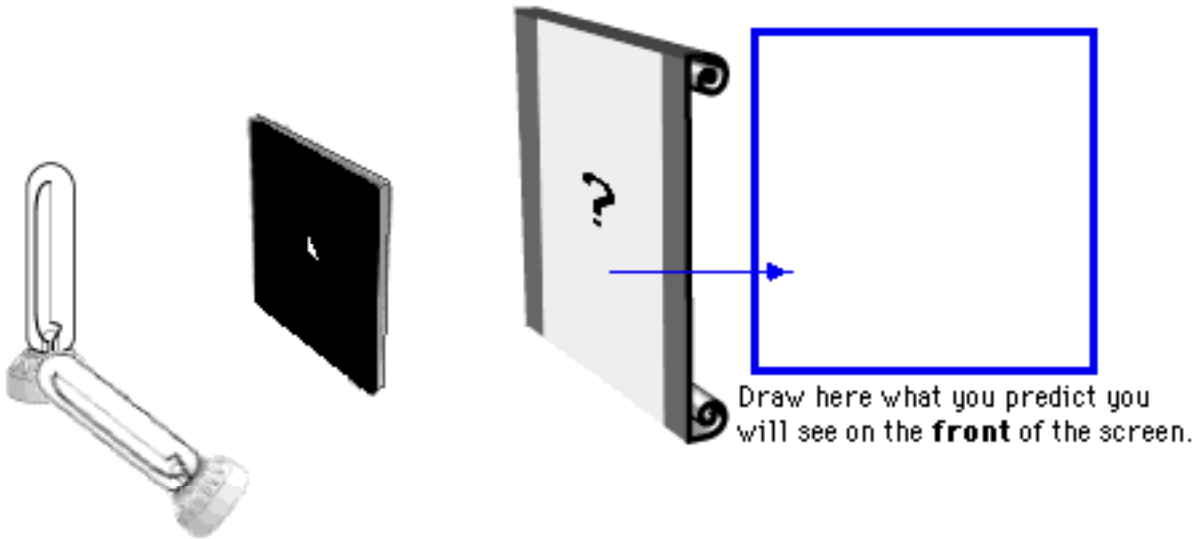

Explain your reasoning.

EXPLORATION

Before you tackle the complex problem, you decide to explore the different light patterns you can get on a screen when light from different kinds of sources shine through holes with different shapes.

1. Suppose you had a maglite, arranged as shown below, close to a card with a small circular hole. **Predict** what you would see on the screen with a lit maglite in a darkened room.

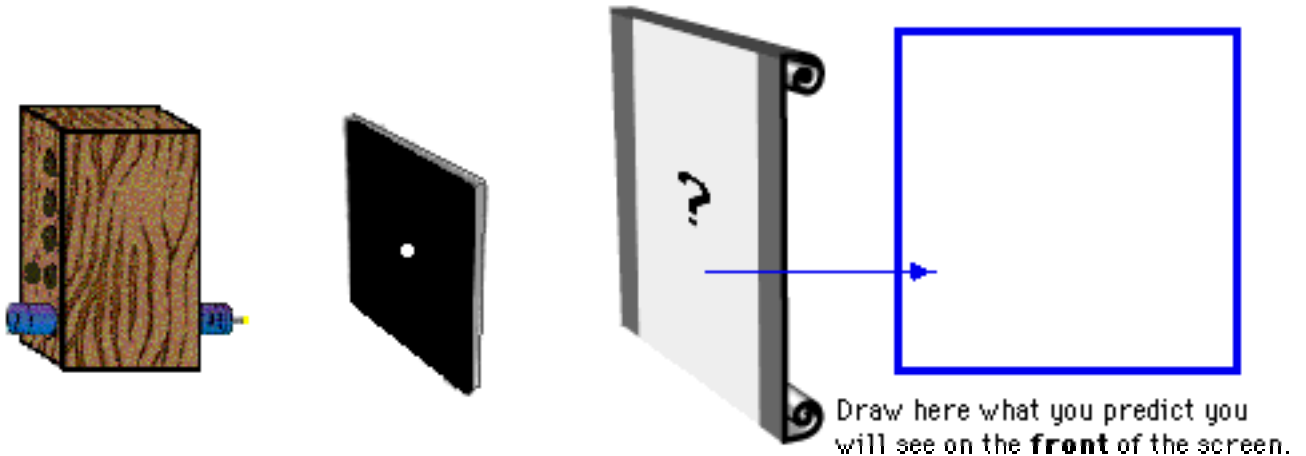

Explain your reasoning.

Predict how moving the maglite upward would effect what you see on the screen. Explain.

Test your predictions. Ask an instructor for a maglite. Unscrew the top of a maglite, and mount the maglite in the lowest hole of the maglite holder, as shown above. Place the card with the circular hole between the maglite and the screen.

If any of your predictions were incorrect, resolve the inconsistency.

2. **Predict** how each of the following changes would affect what you see on the screen. Explain your reasoning and include sketches that support your reasoning.

A. The mask is replaced by a mask with a triangular hole.

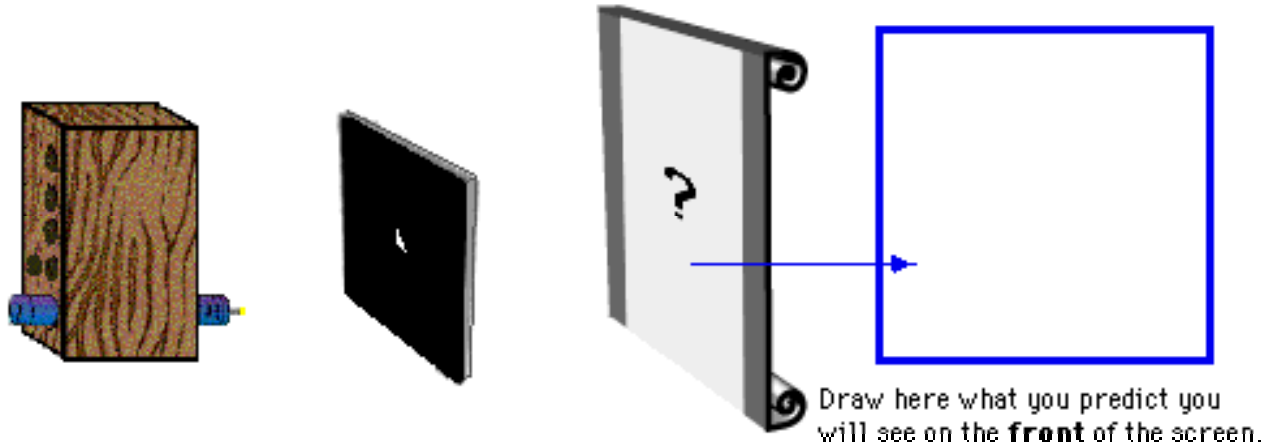

B. The bulb is moved further from the mask.

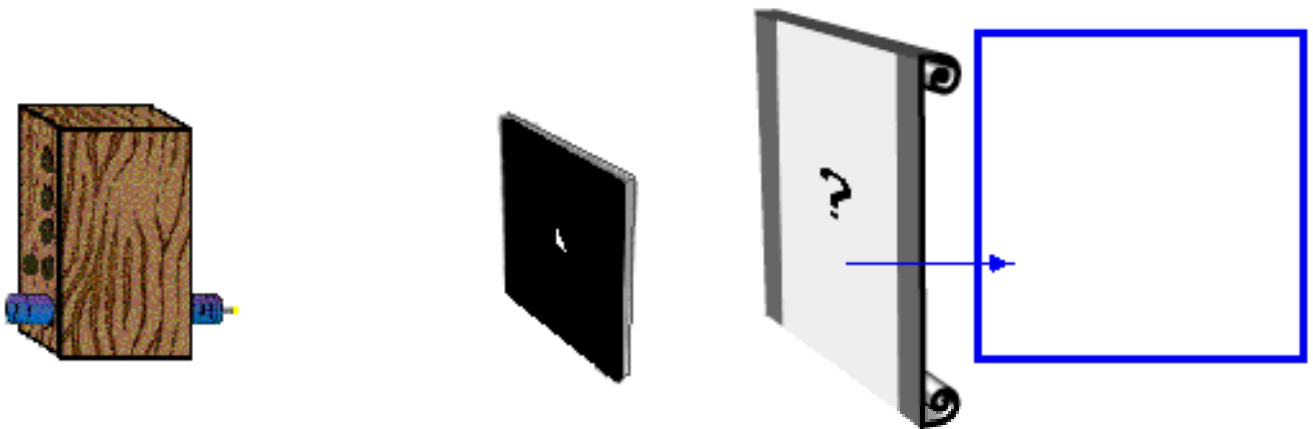

- C. **Test your predictions.** Ask your instructor for a card with a triangular hole, and perform the experiments. If any of your predictions were incorrect, resolve the inconsistency.

3. **Predict** how placing a second maglite above the first would affect what you see on the screen.

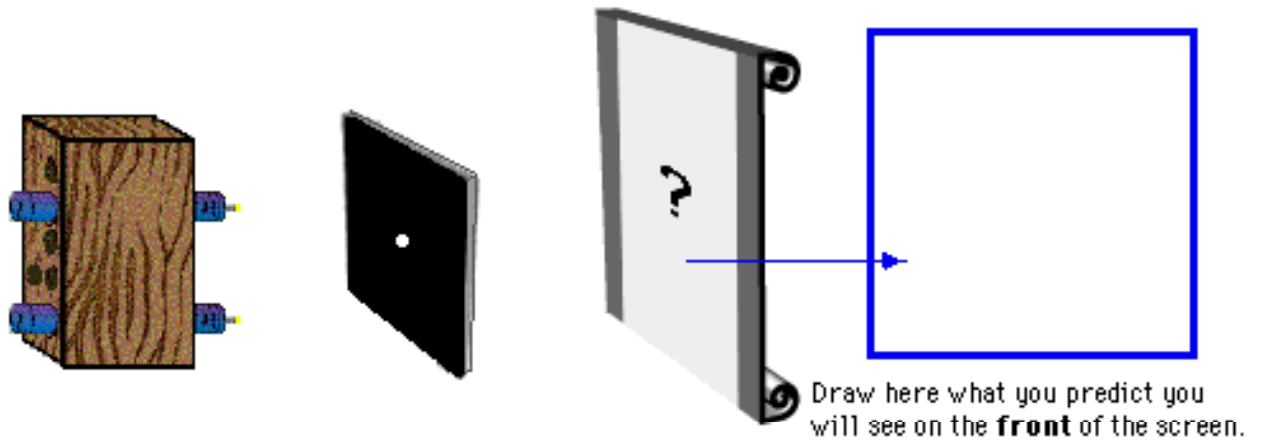

Explain your reasoning.

Test your predictions. Ask an instructor for a second maglite, and perform the experiments. If any of your predictions were incorrect, resolve the inconsistency.

4. What do your observations suggest about the **path** taken by the light from the maglite to the screen?

5. Imagine that you had several maglites held close together, as shown below. **Predict** what you would see on the screen. Explain.

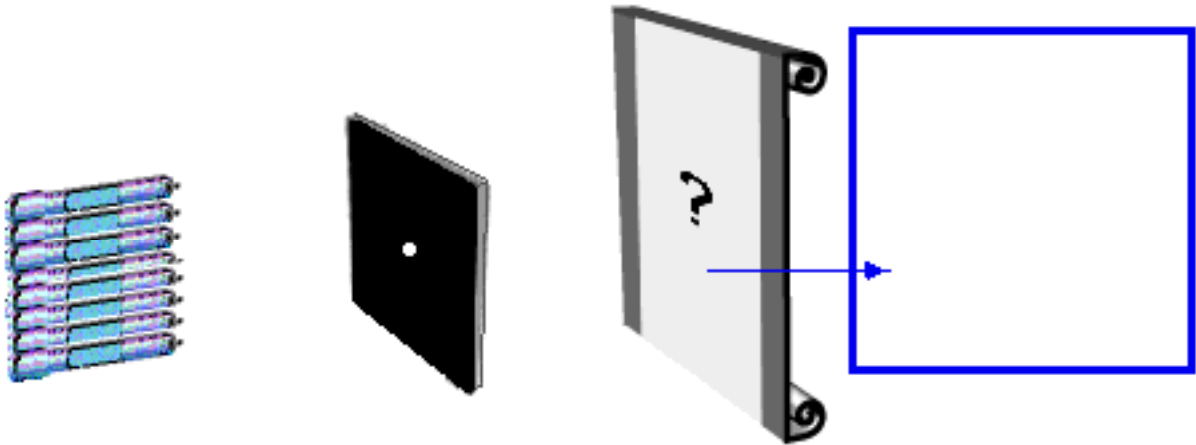

Predict what you would see on the screen if you used a bulb with a long filament instead, as shown below. Explain.

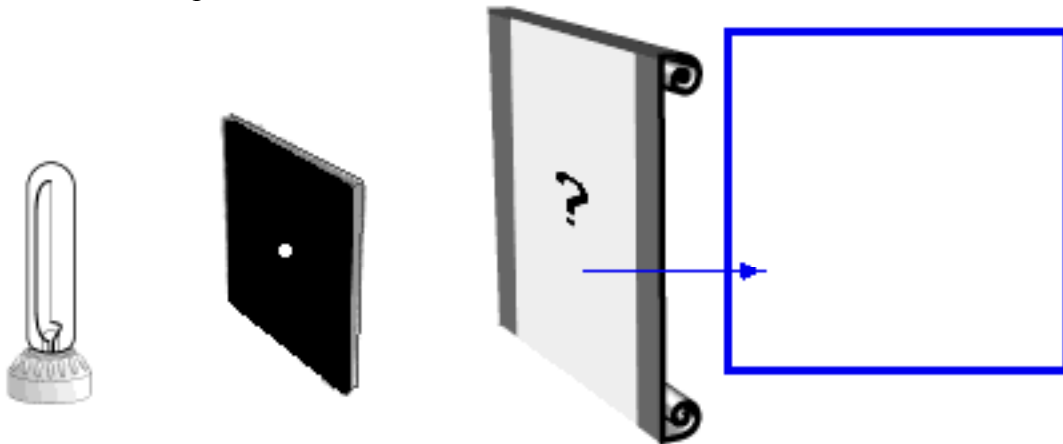

Test your predictions. Ask an instructor for a long filament bulb, and perform the experiments. If any of your predictions were incorrect, resolve the inconsistency.

6. **Individually predict** what you would see on the screen if you had both a maglite and a long filament bulb arranged side by side, as shown at right and below.

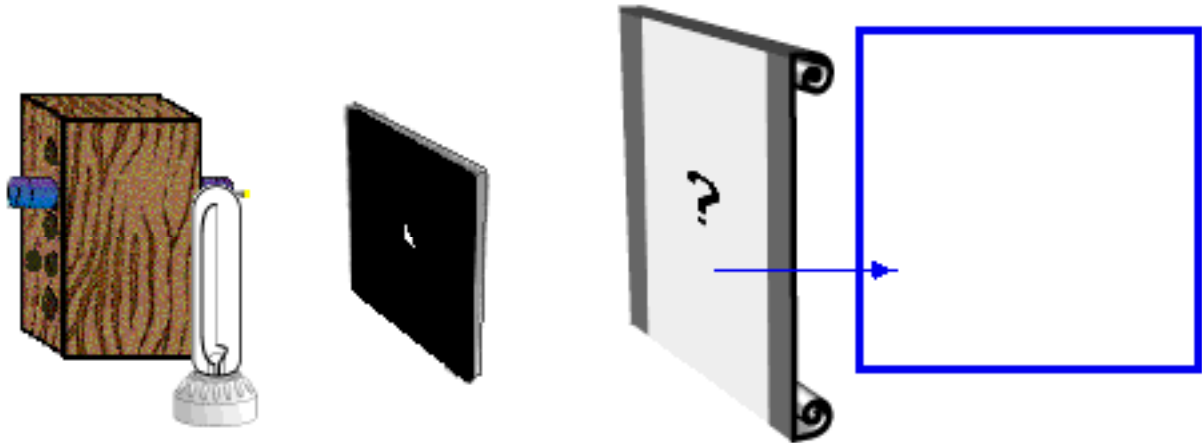

Explain your reasoning.

Compare your prediction with those of your partners. After you and your partners have come to an agreement, **test your prediction** by performing the experiment. Resolve any inconsistencies.

MEASUREMENT & ANALYSIS

You are now ready to investigate the light patterns that would be seen by the witnesses who passed the crime scene.

1. **Predict** what you would see on the screen if you had two long filament bulbs arranged as shown at right and below.

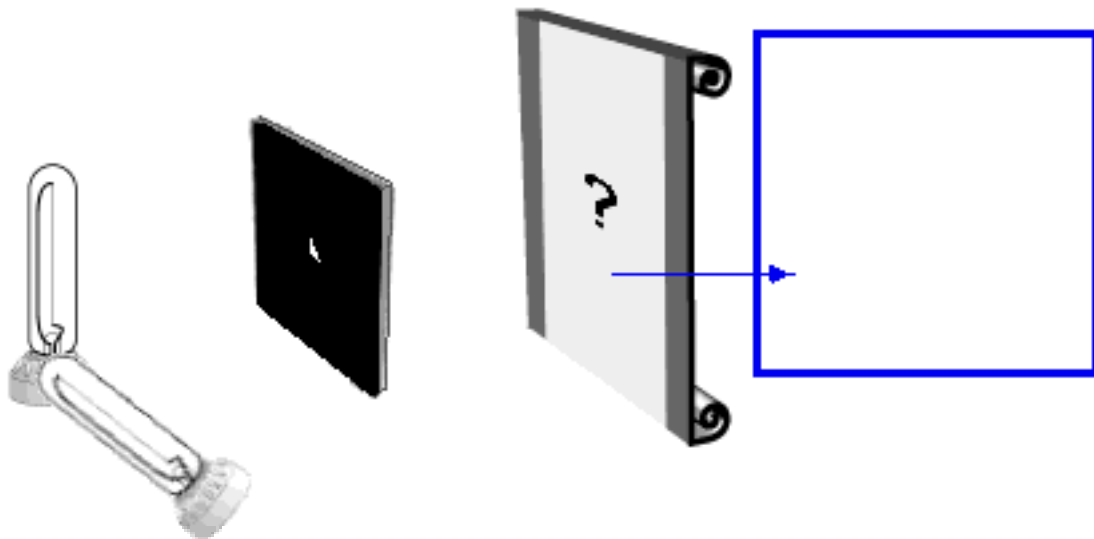
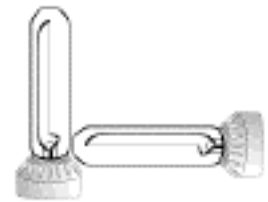

Predict what you would see on the screen if the mask were *removed*.

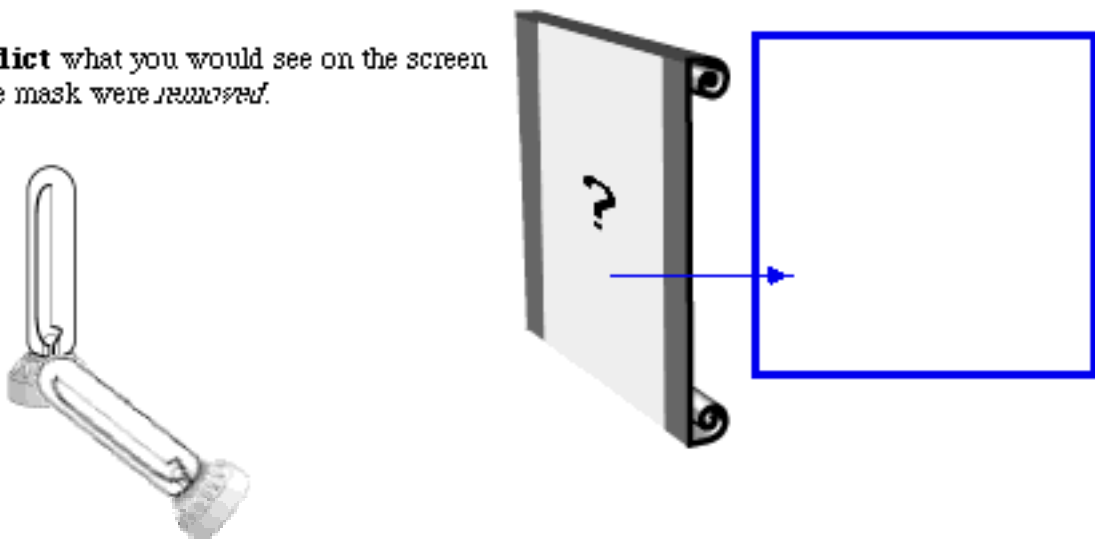

Test your predictions. Ask your instructor for a second long-filament bulb, and perform the experiments. If any predictions were incorrect, resolve the inconsistency.

CONCLUSION

What pattern would a witness see on the building wall from two horizontal lit bulbs through a circular hole and a triangular hole in the window shade? What would a witness see when one bulb was horizontal but the other bulb was vertical? How would you determine the approximate time of the crime?

CHECK YOUR UNDERSTANDING

A mask containing a hole in the shape of the letter **L** is placed between the screen and a very small bulb of a maglite as shown below.

1. On the diagram below, sketch what you would see on the screen when the maglite is turned on.

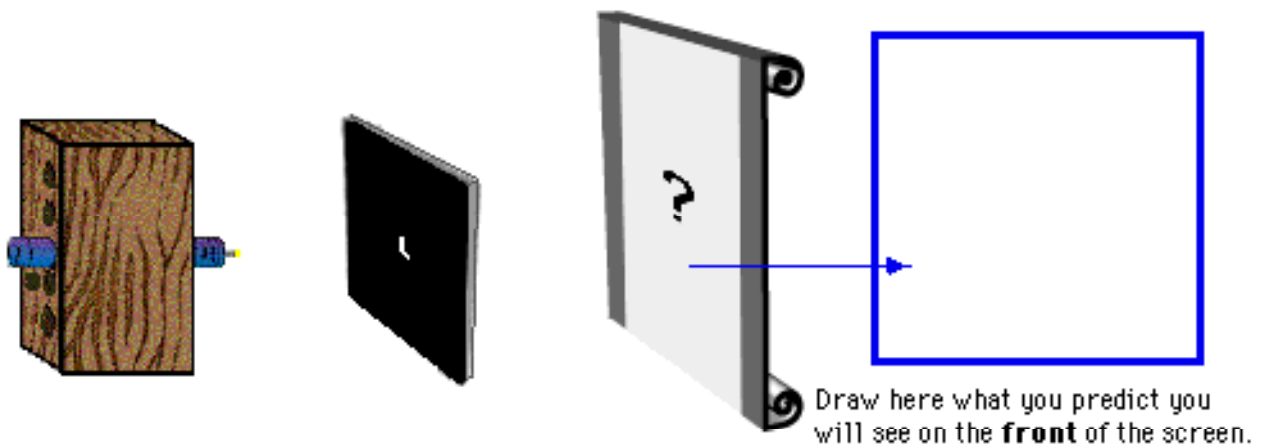

2. The maglite is replaced by three long filament light bulbs that are arranged in the shape of the letter **F**, as shown at right a below.



On the diagram, sketch what you would see on the screen when the bulbs are turned on.
Explain how you determined your answer.

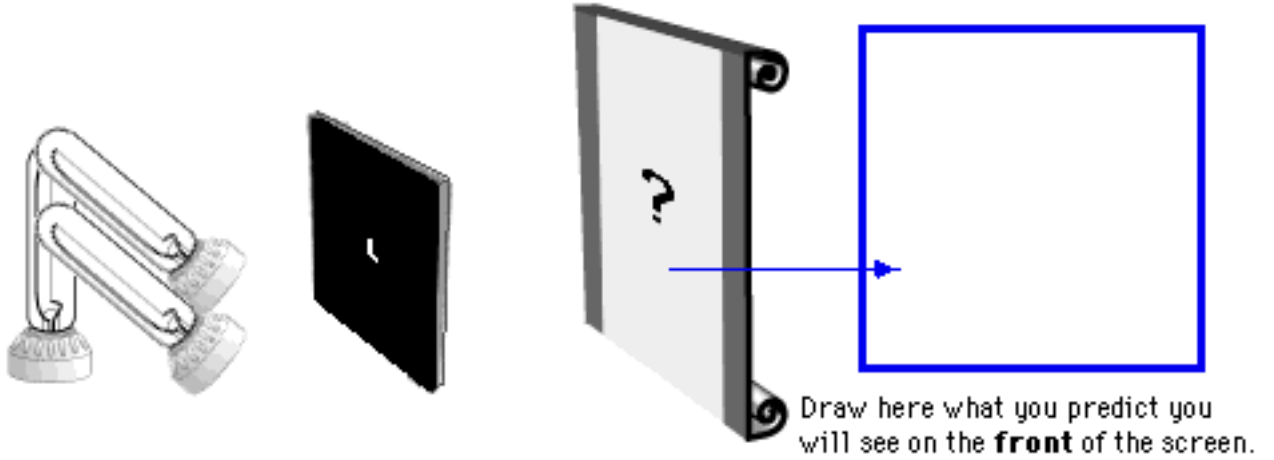

- 3 **Predict** what you would see on the screen when an ordinary frosted bulb is held in front of the mask with the triangular hole, as pictured below. Explain your reasoning.

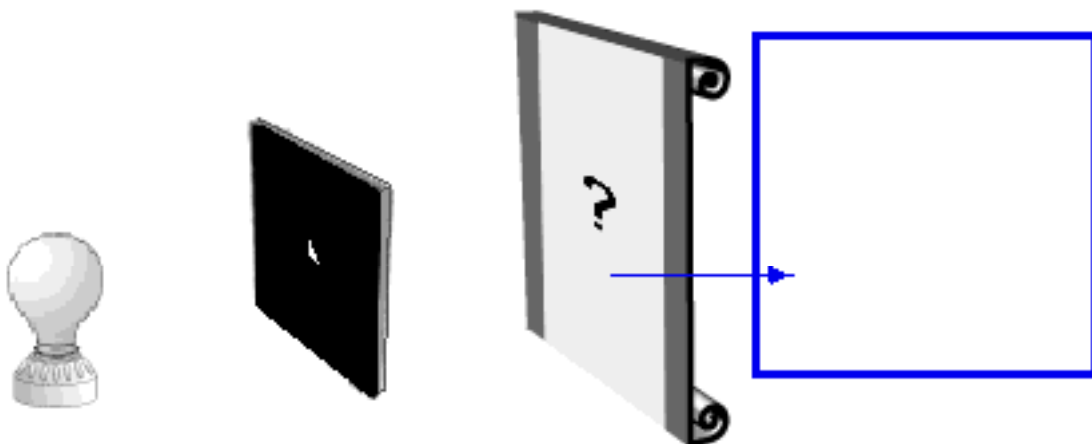

Alternative Conceptions -- Light Patterns

James Wandersee, Joel Mintzes, and Joe Novak (1994) describe several "knowledge claims" that have emerged from the research on students' alternative conceptions in the past 20 years. As you reflect on the activity, *Light Patterns*, describe briefly any examples you experienced of these claims.

Knowledge Claims	Examples from <i>Your Experience</i>
Claim 1: Learners come to formal science instruction with a diverse set of alternative conceptions concerning natural objects and events.	
Claim 2: The alternative conceptions that learners bring to formal science instruction cut across age, ability, gender, and cultural boundaries.	
Claim 3: Alternative conceptions are tenacious and resistant to extinction by conventional teaching strategies.	
Claim 4: Alternative conceptions often parallel explanations of natural phenomena offered by previous generations of scientists and philosophers.	
Claim 5: Alternative conceptions have their origins in a diverse set of personal experiences including direct observation and perception, peer culture, and language, as well as in teachers' explanations and instructional materials.	
Claim 6: Teachers often subscribe to the same alternative conceptions as their students.	
Claim 7: Learners' prior knowledge interacts with knowledge presented in formal instruction, resulting in a diverse set of unintended learning outcomes.	
Claim 8: Instructional approaches that facilitate conceptual change can be effective classroom tools.	

NOTES

LN **What are Alternative Conceptions?**

All learners come to instruction with their own common-sense ideas about how the world works.

These ideas have been gained through their attempts to make sense of the world by describing, explaining, predicting and designing the world around them.

Sometimes learners' ideas match the scientific view of the world. But most often they do not match. When students' ideas do not match the scientific conceptions, students are said to have "alternative conceptions" or "misconceptions."



2

LN **Reconstruction of Knowledge**

Problem (disequilibrium)	"My explanation didn't work." or "My explanation is not the same as my friends' explanations."
Intelligible	"I can at least understand the scientific concept, even if it doesn't make sense."
Plausible	"I see how the scientific concept solves the problem. It is also consistent with other things I know."
Fruitful	"The scientific concept is useful because it solves a lot of other related and seemingly unrelated problems."

3

LS1

What do students learn from traditional physics instruction?



1. **Undisturbed Outcome:** Students' views remain substantially unchanged.
2. **Reinforced Outcome:** Students incorporate the new ideas in ways that reinforce their alternative conceptions.



"It's like the first photographic machine, the camera obscura."

REINFORCES

student's idea that a symmetrical hole produces a symmetrical light pattern on the screen.

4

LS1

3. Two Perspectives Outcome

Students retain two, opposing perspectives:

- (a) their own, used in everyday situations, and
- (b) the scientific view, applied only in school situations (like tests).

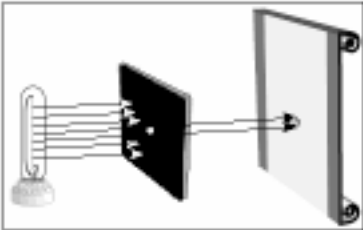
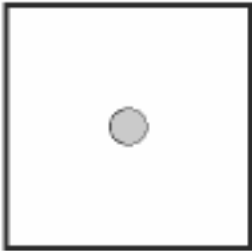



For example, a student who can state correctly that "an extended light source acts like an infinite number of point sources," but still believes that light travels from the source in parallel rays.

5

LN

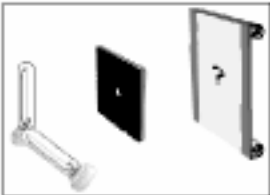
4. **Mixed Outcome:** Students lose confidence in their earlier ideas, but better ideas are not constructed. Students end up with confused or incoherent ideas.

“The form (L shape of bulb filaments) will affect the picture, but there will be a triangle corresponding to the shape of the hole.”

5. Hypothetical “Unified Scientific Outcome:” Students restructure their ideas and build up a coherent, scientific view.

6

LN

Passage

The procedure is actually quite simple. First you arrange them into different groups. Of course, one pile may be sufficient depending on how much there is to do. If you have to go somewhere else due to lack of facilities that is the next step; otherwise, you are pretty well set.

It is important not to overdo things. That is, it is better to do too few things than too many. In the short run this may not seem important, but complications can easily arise. A mistake can be expensive as well. At first, the whole procedure will seem complicated. Soon, however, it will become just another fact of life. It is difficult to foresee any end of the necessity of the task in the immediate future, but then, one can never tell.

After the procedure is completed, one arranges the materials into different groups again. Then they can be put into their appropriate places. Eventually they will be used once more and the whole cycle will then have to be repeated. However, that is a part of life.

7

LSM

Alternative Conceptions of Current Electricity

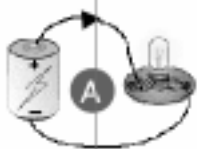

A

All the current is used up by the bulb.

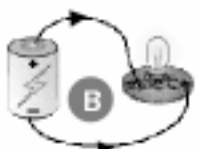

B

"Clashing currents" flow from both end of the battery.

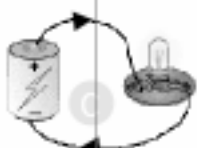

C

Some of the current is used up by the bulb.



D

Current is conserved.

8

LSM

The "Clashing Currents" Model in the History of Science

"Two electricities are carried in such a way that there results a double current, one of positive electricity, the other of negative electricity, starting out in opposite senses from the point where the electromotive action arises, and going out to reunite in the parts of the circuit remote from these points it is this state of electricity in a series of electromotive and conducting bodies which I name for brevity electric current."

Andre Marie Ampere
1775 - 1836

9