

# College Ready Physics Standards: A Look to the Future

**Patricia Heller**  
Physics Education Research Group  
Department of Curriculum and Instruction  
University of Minnesota

**Gay Stewart**  
Department of Physics  
University of Arkansas

## Acknowledgments

The following people assisted in the creation of this document through stimulating discussions of the issues. Thank you to the following:

Ken Heller  
Professor of Physics  
School of Physics and Astronomy  
University of Minnesota  
Minneapolis, Minnesota

Ramon E. Lopez  
Professor  
Department of Physics  
University of Texas at Arlington  
Arlington, Texas

Donovan Hylton  
Assessment Specialist  
Research and Development  
The College Board  
New York, New York

Wolfgang Christian  
Professor  
Department of Physics  
Davidson College  
Davidson, North Carolina

## TABLE OF CONTENTS

<b>Standards Outline</b>	<b>iii</b>
<b>Introduction to College-ready Physics Standards: A Look to the Future</b> .....	<b>v</b>
Organization and Structure of the Standards	vi
Breadth of Coverage versus Depth of Understanding	vii
Goal of Conceptual Understanding	vii
The Learning Outcomes	viii
Instructional Guidance for Each Standard	ix
Using the Physics Objectives	ix
<b>Guide to Using the College-ready Physics Standards</b> .....	<b>x</b>
<b>Standard 1: Interactions, Models, and Scales</b>	<b>1</b>
1.1 Interactions, Systems, and Scale (5-8)	2
1.2 Interactions and Properties (5-8)	4
1.3 Interactions and Atomic and Subatomic Models (5-8 and 9-12)	6
1.4 Interactions and Objects Moving Very Fast (9-12)	10
<b>Standard 2: Conservation Principles</b> .....	<b>13</b>
2.1 Conservation of Mass, Energy, and Charge (5-8 and 9-12)	14
2.2 Conservation of Linear Momentum (9-12)	17
2.3 Nuclear Interactions and The Conservation of Mass-Energy (9-12)	20
<b>Standard 3: Newton’s Laws of Motion</b> .....	<b>23</b>
3.1 Constant and Changing Linear Motions (5-8 and 9-12)	24
3.2 Forces, and Changes in Motion (5-8 and 9-12)	28
3.3 Contact Interactions and Forces (5-8 and 9-12)	31
3.4 Gravitational Interactions and Forces (5-8 and 9-12)	35
3.5 Magnetic and Electrical Interactions and Forces (5-8 and 9-12)	38
<b>Standard 4: Energy Transfer and Storage</b> .....	<b>43</b>
4.1 Contact Interactions and Energy (5-8 and 9-12)	44
4.2 Circuit Interactions and Energy (5-8 and 9-12)	47
4.3 Mechanical Wave Interactions and Energy (5-8 and 9-12)	51
4.4 Radiant Energy Interactions (5-8 and 9-12)	54
4.5 Heating and Cooling Interactions and Energy (5-8 and 9-12)	58
<b>Standard 5: Forces, Energy, and Fields</b> .....	<b>63</b>
5.1 Forces and Fields (5-8 and 9-12)	64
5.2 Energy and Fields (5-8 and 9-12)	66
5.3 Electromagnetic Interactions and Fields (5-8 and 9-12)	70
<b>Guide for Using Instructional Guidance for Each Standard</b> .....	<b>73</b>
<b>Instructional Guidance for Standard 1</b> .....	<b>77</b>

**Instructional Guidance for Standard 2** ..... 89

**Instructional Guidance for Standard 3** ..... 99

**Instructional Guidance for Standard 4** ..... 117

**Instructional Guidance for Standard 5** ..... 139

**Appendix A. Five Principles for How Students Learn** ..... 151

**Appendix B. Research Used for the Tables of Common Student Conceptual Difficulties** ..... 155

**Appendix C. Summary of Research Used to Develop the Standards** ..... 157

**Glossary** ..... 159

**References** ..... 165

# LIST OF STANDARDS AND OBJECTIVES

## STANDARD 1. INTERACTIONS, MODELS, AND SCALE

*Changes in the natural world are the result of interactions. The description, explanation, and prediction of interactions depend on the size and time scale and our models of the structure of matter. For objects moving very fast, the macro (human) scale ideas of absolute time and space must be revised.*

### Objective 1.1 Interactions, Systems, and Scale

(Grades 5-8)

*Students understand that observed changes in our world are the result of interactions. The description, explanation, and prediction of interactions depends on the defined system and defined time interval, and the size and time scales involved [cosmic, macro (human), and the atomic and subatomic domains of magnitude].*

### Objective 1.2 Interactions and Properties (Grades 5-8)

*Students understand that at the macro (human) scale, the properties of objects are qualitative and quantitative descriptions of how the objects interact with other objects or systems. Properties that do not depend on the amount of material can be used to identify the material.*

### Objective 1.3 Interactions and Atomic and Subatomic Models

(Grades 5-8 and Grades 9-12)

*Students understand that different mental models are useful at the atomic scale (small particle model of matter) and subatomic scale (quantum mechanics) for describing, explaining and predicting events, processes, and the properties of systems.*

### Objective 1.4 Interactions and Objects Moving Very Fast

(Grades 9-12)

*Students understand that the Newtonian ideas about absolute space and time are incorrect, as Einstein demonstrated with his special theory of relativity.*

## STANDARD 2. CONSERVATION PRINCIPLES

*The interaction of one object with another object is governed by a few conservation principles. These principles are considered fundamental because they apply to interactions at all time and size scales and cannot be derived from other theories.*

### Objective 2.1 Conservation of Mass, Energy, and Charge

(Grades 5-8 and Grades 9-12)

*Students understand that at the macro (human) scale, mass and energy are conserved separately, within measurement errors, for all types of interactions and defined systems (open or closed). Charge is always conserved at all scales.*

### Objective 2.2. Conservation of Linear Momentum

(Grades 9-12)

*Students understand that linear momentum is conserved at all size and time scales, and for all types of interactions and defined systems (open or closed).*

### Objective 2.3. Nuclear Interactions and the Conservation of Mass-Energy

(Grades 9-12)

*Students understand that nuclear interactions result in product particle(s) with less mass than the original particle(s); the missing mass appears as an energy transfer out the system. Mass-energy is conserved at all size and time scales, for all types of interactions, and for all defined systems (open or closed).*

## STANDARD 3. NEWTON'S LAWS OF MOTION

*Interactions of an object with other objects can be described, explained, and predicted using the concept of forces, which can cause a change in motion of one or both interacting objects. Different types of interactions are identified by their defining characteristics. At the macro (human) scale, interactions are governed by Newton's second and third laws of motion.*

### Objective 3.1 Constant and Changing Linear Motion

(Grades 5-8 and Grades 9-12)

*Students understand that linear motion is characterized by speed, velocity, and acceleration, and that velocity and acceleration are vectors.*

### Objective 3.2 Forces and Changes in Motion

(Grades 5-8 and Grades 9-12)

*Students understand that interactions can be described in terms of forces. The acceleration of an object is proportional to the vector sum of all the forces (net force) on the object and inversely proportional to the object's mass ( $a = \Sigma F/m$ ). When two interacting objects push or pull on each other, the force on one object is equal in magnitude but opposite in direction to the force on the other object.*

### Objective 3.3 Contact Interactions and Forces

(Grades 5-8 and Grades 9-12)

*Students understand that contact interactions occur when two objects in contact push or pull on each other, which can cause a change in the motion of the objects. Some types of contact interactions have force laws that are empirical approximations; some have no force laws.*

### Objective 3.4 Gravitational Interactions and Forces

(Grades 5-8 and Grades 9-12)

*Students understand that gravity is an attractive interaction between any two objects with mass, which can cause a change in the motion of the objects. Gravitational interactions are governed by a force law.*

### Objective 3.5 Magnetic and Electrical Interactions and Forces

(Grades 5-8 and Grades 9-12)

*Students understand that both magnetic interactions and electrical interactions occur between mutually attracting or repelling objects, which can cause a change in the motion of the objects. Electrical interactions apply to point charges and are governed by a force law.*

## **STANDARD 4. ENERGY TRANSFERS AND STORAGE**

*Interactions of an object with other objects can be described and explained by using the concept of the transfer of energy from one object to another, both within a defined system and across the boundary of the system. Energy transfers across the boundary of a system can change the energy within the system. In the conservation of energy equation, one or more energy transfers across the system boundary or energy changes within the system could be applicable, not applicable, or too small of an effect to be measurable, depending on the problem situation.*

### **Objective 4.1 Contact Interactions and Energy** (Grades 5-8 and Grades 9-12)

*Students understand that a mechanical energy transfer (work) across the boundary of a system can change the stored kinetic energy, elastic energy, thermal energy, chemical energy, or other types of energy stored within the system.*

### **Objective 4.2 Electric Circuit Interactions and Energy** (Grades 5-8 and Grades 9-12)

*Students understand that the electric charges that flow in the circuit are in the conductors of the circuit. A battery or other source moves electric charges through the circuit but does not create electric charges. An electrical energy transfer from the source of electric current to the electrical device(s) in a circuit can change the energy stored in the system. All electrical devices transfer energy out of the system. The energy changes within the system depend on the properties of the electrical energy source and the electrical device(s) in the circuit.*

### **Objective 4.3 Mechanical Wave Interactions and Energy** (Grades 5-8 and Grades 9-12)

*Students understand that a mechanical wave from a vibrating source transfers energy through a material to surrounding objects without a transfer of material. Interaction of a mechanical wave with different objects can cause the path of the wave to change. Energy changes within the receiver object depend on the properties of the object.*

### **Objective 4.4 Radiant Energy Interactions** (Grades 5-8 and Grades 9-12)

*Students understand that radiant energy from a source can be transferred to surrounding objects without a material (medium), and there are two models of how this happens. The energy*

*changes within a receiver object depend on the properties of the object. There is a continuous range of radiant energies, which includes visible light. Humans can only perceive visible light energy — either from a source or that which is reflected off objects — when the light interacts with the eye–brain system.*

### **Objective 4.5 Heating and Cooling Interactions and Energy** (Grades 5-8 and Grades 9-12)

*Students understand that a thermal energy transfer (heat) from one object to another can change the thermal energies of the objects. The interactions depend on the properties of the materials and on how far the system is from equilibrium. There are three different methods of thermal energy transfer: conduction, convection, and thermal radiation. At a constant temperature in any time interval, the amount of thermal radiation emitted by an object to its surroundings is equal to the amount of thermal radiation absorbed by the object from its surroundings in that same time interval (thermal equilibrium).*

## **STANDARD 5. FORCES, ENERGY, AND FIELDS**

*Attractive and repulsive interactions at a distance (e.g., gravitational, magnetic, electrical and electromagnetic) can be described and explained using a field model. The field model explains how objects exert attractive and repulsive forces on each other at a distance, and where energy is stored in the system.*

### **Objective 5.1 Forces and Fields** (Grades 5-8 and Grades 9-12)

*Students understand that the field model explains how objects exert attractive and repulsive forces on each other at a distance: their fields are the agents of the interaction.*

### **Objective 5.2 Energy and Fields** (Grades 5-8 and Grades 9-12)

*Students understand that the field model explains where the energy is stored in a system of two mutually attracting or repelling objects -- in the field of the system. Only systems (not single objects) can have field (potential) energies. Energy can be transferred to and from the field of the system.*

### **Objective 5.3 Electromagnetic Interactions and Fields** (Grades 5-8 and Grades 9-12)

*Students understand that an electromagnetic interaction occurs when a flow of charged particles creates a magnetic field around the moving particles, or when a changing magnetic field creates an electric field.*

# COLLEGE-READY PHYSICS STANDARDS: A LOOK TO THE FUTURE

## INTRODUCTION

### **Standard 1 Interactions, Models and Scale**

*Changes in the natural world are the result of interactions. The description, explanation, and prediction of interactions depend on the distance and time scale and our models of the structure of matter. For objects moving very fast, the macro (human) scale ideas of absolute space and time must be revised.*

### **Standard 2: Conservation Principles**

*The interaction of one object with another object is governed by a few conservation principles. These principles are considered fundamental because they apply to interactions at all time and distance scales and cannot be derived from other theories.*

### **Standard 3: Newton's Laws of Motion**

*Interactions of an object with other objects can be described, explained, and predicted using the concept of forces, which can cause a change in motion of one or both interacting objects. Different types of interactions are identified by their defining characteristics. At the macro (human) scale, interactions are governed by Newton's second and third laws of motion.*

### **Standard 4: Energy Transfers and Storage**

*Interactions of an object with other objects can be described and explained by using the concept of the transfer of energy from one object to another, both within a defined system and across the boundary of the system. Energy transfers across the boundary of a system can change the energy within the system. In the conservation of energy equation, one or more energy transfers across the system boundary or energy changes within the system could be applicable, not applicable, or too small of an effect to be measurable, depending on the problem situation.*

### **Standard 5: Forces, Energy, and Fields**

*Attractive and repulsive interactions at a distance (e.g., gravitational, magnetic, electrical and electromagnetic) can be described and explained using a field model. The field model explains how objects exert attractive and repulsive forces on each other at a distance, and where energy is stored in the system.*

Since the 1990's, there have been several projects to develop national science standards. In 1993, the American Association for the Advancement of Science published the Project 2061 *Benchmarks for Science Literacy* (BSL). The benchmarks are reported for three grade level bands, grades K-5, grades 6-8, and grades 9-12. A few years later (1996), the National Research Council published the *National Science Education Standards* (NSES). The purpose of these standards was improvement in the scientific literacy of *all* Americans. Many states adopted one of these national science standards.

One problem for K-12 physics education is that the national standards embed the physics content standards with many other standards, such as standards for the nature of science, science as inquiry, the history of science, science and technology, unifying concepts and processes of science, and many others. The content standards seemed to be less important than all the other standards. For example, physics standards are in only in one of thirteen chapters of BSL (The Physical Setting), along with all the content standards for earth sciences, astronomy, and chemistry. This made it difficult for state curriculum supervisors or curriculum developers to place some of the broad content standards in a meaningful curriculum context.<sup>1</sup> The overwhelming number of benchmarks or standards also led to diffuse, unfocused state content standards (Fordham Institute, 2005; Pacific Research Institute, 1999).

Another problem with the K-12 national and state standards is the lack of learning outcomes for students – what we expect students to do with their knowledge to both build their understanding of the content and to demonstrate their mastery of the content. This became an issue in 2000 with the advent of No Child Left Behind, which emphasized assessment of content knowledge. In 2009, the College Board published *Science Standards for College Success* [SSCS], which focuses on science content standards and includes examples of learning outcomes (performance expectations). The purpose of these standards is to help states, school districts and schools provide students with the rigorous education that will prepare them for success in college introductory science courses and enriched opportunities in the workplace.

The state standards based on the national standards and the College Board standards have one issue that that has not been addressed. Physics and chemistry are always combined into “physical science” at the middle school level. Consequently, middle school standards are often unfocused and the level of physics knowledge and reasoning required does not prepare students for high school physics (Fordham Institute, 2005).

The K-12 physics standards in this document resolve this issue. They reflect the rigorous progression of learning from elementary school

<sup>1</sup> The AASA addressed this issue, in part, by publishing concept maps for different topics, filling in some of the missing content. [AAS, Atlas for Science Literacy, Volume 1 (2001) and Volume 2 (2007)]

through middle school to high school that is required to meet the goal of depth of conceptual understanding of physics. The standards look to the future, when school districts vertically align their curriculum and instruction K - 12, avoiding unnecessary repetition of content. With the depth of understanding and qualitative and quantitative problem solving skills that could be developed by the time students graduate high school, the introductory physics courses in college could reflect the kind of preparation students need to enter many different professions. Additionally, the College Board AP Physics B™ course could be reduced from two years to one year.

## ORGANIZATION AND STRUCTURE OF THE STANDARDS

The Advanced Placement (AP) Physics Redesign Commission for the College Board completed a physics-domain analysis, which resulted in seven “big ideas” or core principles of physics for the new AP Physics B courses. The authors of these College Ready Physics Standards revised this analysis to be suitable for grades K-12. The physics standards are organized around five core ideas of physics: Interactions, Models, and Scale; Conservation Principles; Newton’s Laws of Motion; Energy Transfers and Storage; and Forces, Energy, and Fields (see sidebar on previous page). The central organizing theme of the standards is the concept of interaction. Two objects (which can be a defined quantity of a solid, liquid or gas) interact when they act on or influence each other to cause some effect. The evidence of the interaction is usually the effect — an observed change (e.g., change in motion, shape, mass, temperature, state) in one or both objects. Interaction is a causality statement in physics. In classical physics, the concepts of forces, energy transfers, linear momentum transfers, and fields are four ways physicists describe, explain, and predict events, processes, and the properties of systems.

While there are five standards, they are not meant to represent an equal division of physics concepts and principles. Each standard has three to five objectives that provide detailed descriptions of specific physics concepts students should learn. The objectives are the focus of student mastery, and the key elements of the interactions conceptual framework.

Each objective is, in turn, supported by:

- Elementary Foundational Knowledge – a set of 3 - 6 statements of what students should know by the end of the fourth grade. These statements primarily come from the AAAS *Benchmarks for Science Literacy, Online Version* [BSL].
- A set of 4 - 8 essential knowledge (EK) statements for both middle school (grades 5-8) and high school (grades 9-12). The EK statements are the conceptual targets for student learning. They provide a more detailed description of the broader knowledge delineated in the objective statement. The EK statements should not be viewed as a list of discrete, unrelated facts for students to memorize, but as a set of interrelated ideas. The essential knowledge statements also provide the language and appropriate terminology that students should use as they complete the tasks described in the learning outcomes.
- A set of 5 - 10 learning outcomes (LOs) for both middle school (grades 5-8) and high school (grades 9-12). The learning outcomes describe what students should be able to do in order to build and reason with, as well as apply the essential knowledge that is necessary to understand the content delineated in the objectives. In general, the LOs for each grade level are ordered from the least to most difficult.

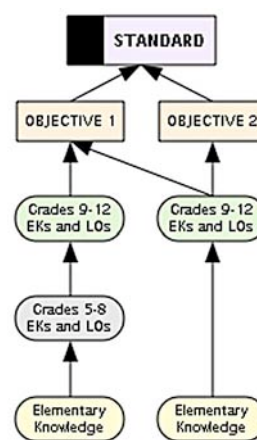

The physics standards reflect current research about student learning by identifying and building on previous knowledge in a cumulative manner, and requiring increasing intellectual sophistication and higher levels of abstraction from elementary school to middle school through high school. See Appendix B for the Principles of Learning used in these standards, and Appendix C for a research summary of conceptual and problem-solving difficulties students have learning physics.

The order of the standards and objectives does not indicate a linear progression through physics. For example, two of the high school objectives in the first standard would not be addressed until near the end of a course. The learning pathways within each objective are not developmentally inevitable, nor is there a single “correct order” (Smith, Wisner, Anderson, Krajcik, & Coppola, 2004). There are multiple pathways by which certain understandings can be reached. Learning outcomes and essential knowledge statements from more than one objective, possibly from more than one standard, are often required for students to apply their knowledge in a particular physics topic. Within each objective, the learning progression is rigorous, but this provides the curriculum specialists and curriculum developers more possible pathways through a curriculum because the prior knowledge to develop a new understanding can be determined from



the essential knowledge statements. The number of learning objectives or essential knowledge statements required to support the understanding of any objective does not reflect the importance of the objective. Some objectives require more supporting knowledge than others. Similarly, research indicates that some learning outcomes must be given more instructional time than others.

## BREADTH OF COVERAGE VERSUS DEPTH OF UNDERSTANDING

Two current issues within science education are the large number of concepts taught in each science discipline and the repetition of the same discipline content in middle school and high school science courses. Both of these practices leave little time in a school year for developing students' depth of understanding of key physics concepts and core principles. The physics standards are designed to address these issues.

In order to provide adequate time for instructors to teach fewer concepts in depth during each grade band, tough decisions were made to restrict the breadth of coverage and prevent unnecessary redundancy of basic ideas in middle school and high school. For example, the physics standards for force and motion are limited to straight-line motion and horizontal and vertical forces. (The exceptions are uniform circular motion and forces, which were included because of their importance for astronomy topics in the earth sciences, and a suggested extension activity for projectile motion.) Two- and three-dimensional forces are excluded from the standards. This decision narrows the breadth of information and leaves time for students to develop depth of physics understanding both within the *Newton's Laws of Motion* standard, as well as in the other physics standards. Limitations to breadth of coverage are indicated in boundary statements that appear after standard or objective statements.

The physics objective for force and motion also illustrates the prevention of unnecessary repetition of basic ideas. At the middle school level, students learn and apply the concepts of constant and average speeds for straight-line motion. A *change in motion* (speeding up, slowing down, and/or changing direction) is associated with the sum of the forces on an object. These ideas are not repeated at the high school level. Instead, the high school level builds on and extends these ideas to the more abstract concepts of displacement, constant and average velocity, instantaneous velocity, and acceleration in the horizontal or vertical direction. The linear acceleration of an object is related to the sum of forces (net force) on the object [ $a = \Sigma F/m$ ]. Similarly, in middle school the students develop the important basic skills of defining a system of interest and identifying interactions by their defining characteristics. These skills are used and reinforced at the high school level, without the need for repeat teaching of the basic skills. The principle of conservation is carefully developed at the middle school level in the context of conservation of mass, a quantity that can be understood and measured at this level. The high school level extends the use of the conservation principle to charge, energy (macro scale), linear momentum and mass-energy.

A further example of reduction of breadth of coverage is placing less emphasis on plug-and-chug calculations and limiting the number of equations students are required to understand and use. Research indicates that students can often manipulate equations without understanding the concepts. Real problem solving skills are developed with the depth of conceptual understanding that allows a student to understand why they would choose to use an equation. For some learning outcomes, an equation *is* required. In these cases, the equation appears within an essential knowledge statement or in parentheses at the end of the statement. At the middle school level (grades 5-8), only 9% of the learning outcomes require students to solve a simple quantitative problem involving density, average speed, or wave speeds. Only 26% of the high school (grades 9-12) learning outcomes require students to write an equation or solve a problem mathematically. It should be noted that the symbols in the equations do not have to be the same as those shown.

Another difficult decision was made regarding depth of understanding of energy and the conservation of energy principle, particularly at the middle school level. Energy is not a mechanism that explains how things happen, nor can students at the middle school level measure energies. Consequently, energy conservation has no immediate practical use at this level. The introduction to energy concepts at the middle school level should provide an integrating framework that can be used to think about an enormously wide range of phenomena, across all the sciences (Millar, 2005). Standard 4 emphasizes the representation, both verbally and with diagrams, of a variety of events and physical processes in terms of energy transfers within a defined system, energy transfers across the boundary of the system, and the changes of energy within the system. At the high school level, a few different forms of energy and methods of energy transfer can be measured and calculated. The verbal and diagrammatic energy representations of phenomena are extended to include the mathematical representation and interpretation of

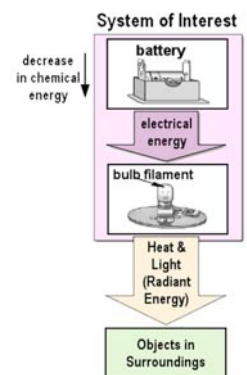

---

the conservation of energy principle: the total change in energy within a defined system is equal to the total transfer of energy into or out of the system (Jewett, 2008d).

## GOAL OF CONCEPTUAL UNDERSTANDING

For physics to be useful and interesting to students, they must understand the core principles of physics in terms of how the ideas are related to a wide range of phenomena (see Appendix A, page 151). This learning principle also influences the depth vs. breadth issue as students see there is only one conservation principle which they can apply to mass, charge, energy, mass-energy and linear momentum, or that so many separate laws and theorems are simply special cases of the law of conservation of energy. To reduce the students' tendency to rely on memorization, the advice of Arnold Arons (1996) was adopted. He showed that depth of understanding requires students to first develop the idea that requires the technical term. In these standards, before a technical term is introduced, a simpler term or statement that summarizes the meaning of the technical term is used. This applies to Greek and Latin terms, such as motion (kinetic) energy, as well as common words that have a different, very specific physics definition, such as thermal energy transfer (heat).

These standards also take into account the large number of research studies in physics education and cognitive psychology that address how students learn physics concepts and problem-solving skills, and that address students' pervasive conceptual difficulties.<sup>‡</sup> It would be a disservice to students to ignore this extensive research literature. The research literature guided the writing of the learning outcomes and the essential knowledge statements. Appendix B contains a description of the process used to summarize the research literature on a *Table of Common Student Conceptual Difficulties* for each physics objective. Each Table includes the most relevant essential knowledge statements and learning outcomes that give teachers the opportunity to address the conceptual difficulty.

Only appropriate curricula and instruction can address students' pervasive conceptual difficulties as found in the extensive research literature. Conceptual understanding cannot be achieved, however, without developing some qualitative and quantitative problem-solving skills. For example, to collect and share information and to build understanding of the world around them, students must be able to use many different forms of representation, and also be able to translate between representations. They must be able to identify what concepts or principles are applicable in any situation, recognize interactions and identify the interactions through their defining characteristics, and recognize when a simplifying assumption can be made. In addition, these standards assume that students are enrolled in mathematics courses that meet the *College Board Standards for College Success: Mathematics and Statistics*<sup>™</sup> (2006).

## LEARNING OUTCOMES

The types of tasks and activities students should engage in to build their knowledge and demonstrate mastery include: calculate; compare and contrast; give real-world examples of; describe; translate among different representations; analyze different real-world situations; explain why or how; and predict (qualitatively and quantitatively). Several themes are also carried out in the learning objectives. One theme is investigation. Below is an example from the *Newton's Laws of Motion* standard for the middle school level.

*Investigate the patterns of motion of objects in different experimental situations (limited to straight-line motion):*

- ◆ *Ask and refine a scientific question about the basic pattern of motion of the object.*
- ◆ *Determine and justify the data needed to answer the scientific question about the pattern of motion of the object*
- ◆ *Follow a protocol to collect, record and organize data about the position of the moving object at different times (clock readings). Data include estimates of measurement errors.*
- ◆ *Analyze the data for outliers, and represent the motion of the object on a graph showing distance versus time, and with a motion diagram.*
- ◆ *Determine whether the data can be used as evidence to support a claim about the pattern of motion.*
- ◆ *Make a claim about the pattern of motion of the object. Justification should include the evidence and knowledge of the different patterns of motion of objects (i.e., no motion, moving with a constant speed, speeding up, slowing down, and changing (reversing) direction of motion).*

A related theme is recognizing (grades 5-8) and evaluating (grades 9-12) when the evidence is convincing enough to support a claim. For example:

---

<sup>‡</sup> Underlined words and phrases are defined in the glossary.

---

Recognize when the evidence is convincing or not convincing to support claims about the pattern of motion of an object, using the criteria: (a) appropriate match of the evidence to the question; (b) adequate precision and accuracy (i.e., adequate precision of measuring instruments, adequate care taken in measurement procedures, and sufficient data was collected – sample size was large); (c) adequate data analysis and representation procedures were used; and (d) the investigation was replicated (by other groups or classes).

Another theme is constructing mental models and analogue models and evaluating the usefulness of the models. Two examples from middle school include:

*Construct analogue models of the conservation principle from everyday life. Explain how the analogue model is the same and different from the conservation of mass principle.*

*Recognize when small-particle explanations of different physical properties of room temperature gases, liquids, and solids are good or poor, using the criteria: (a) the explanation links the macroscopic property of the gas, liquid, or solid to the relevant small-particle model idea(s); (b) the explanation is based on the correct small-particle model idea(s), and (c) the explanation is complete (no important small-particle model ideas are missing from the explanation).*

A final theme that pervades the objectives is the domains of magnitude of distance and time (i.e., cosmic scale, macro (human) scale, atomic scale, and subatomic scale). An example from the middle school objective about the small particle model of matter is:

*Give examples of objects to add to a chart that shows the atomic and part of the macro (human) size scale (about  $10^{-10}$  m to  $10^{+3}$  m). Investigate the range in sizes that can be seen with the unaided eye, a visible light microscope, and instruments like the electron microscope.*

## INSTRUCTIONAL GUIDANCE FOR EACH STANDARD

The second part of this document comprises five sections of instructional guidance, one for each standard. Each standard is divided by objective. These sections provide guidance for interpreting the essential knowledge statements and learning outcomes in each objective, particularly the difference in the level of intellectual abstractness and sophistication of reasoning expected at the middle school and high school levels.

Three items in each objective guide the interpretation of the essential knowledge (EK) statements and learning outcomes (LOs). The first is a *Table of Common Student Conceptual Difficulties* for the content of the objective. The table also includes the specific LOs and EK statements that most directly provide teachers the opportunity to address the conceptual difficulty. The second item of instructional guidance is a *Table of Content Boundaries* for each grade level band. These tables outline the objects and phenomena appropriate for the learning outcomes, and any other limitations to the content. They also summarize the models and representations, as well as the technical terms introduced in the objective. Finally, most objectives include some example questions and problem situations for a few of the learning outcomes. These examples are intended to illustrate how the essential knowledge in the objective is to be developed and used through reasoning and in problem solving.

## USING THE PHYSICS OBJECTIVES

The objectives in these standards are longer than other national and state standards because they are research-based and explicitly incorporate several themes. While the extra length requires more effort to read, the learning progressions from elementary school to middle school through high school are unmistakable. This should make it easier for school districts to plan any required changes needed in their physics curriculum and instruction K-12 to prepare students for success in college and the work place.

While these are physics standards, some of the content at the middle school level (grades 5 – 8) could be addressed in the other sciences. For example, the properties of objects (including density), thermal energy transfers (heat) by conduction, convection, and radiation, and the transfer of mechanical waves in solids could be addressed in an earth science class.

Some essential knowledge statements and learning outcomes, especially at the high school level, are the same as in the College Board *Science Standards for College Success™* (SSCS, 2009). They are referenced by page number.

# Guide to Using the College-ready Physics Standards

Since the physics standards do not imply a curriculum or instructional order, the reader should begin where he or she is the most comfortable. If you want an overview of the major themes of the standards, start with Standard 1 (Interactions, Scales, and Models) and Standard 2 (Conservation Principles). If you want to begin with familiar content, go to Standard 3 (Newton's Laws of Motion) or Standard 4 (Energy Transfer and Storage).

**Objectives** describe the target understanding for college readiness; they explain specific learning goals that relate to the corresponding standard. Like the standards, each objective has a unique code as well as a corresponding key phrase.

**Elementary Foundations** specify what student should know at the end of Grade 4. The number in square brackets refers to the statement in *Benchmarks for Science Literacy: Online*.

**Related Objectives** are provided to show how the content of a given objective links to the content of other objectives in different standards.

**Essential Knowledge** statements describe the key concepts for student learning that support the corresponding objective. They provide the language and boundaries of the learning outcomes.

**Footnotes** refer to sections of the document that contain instructional guidance and a *Table of Common Student Conceptual Difficulties* for each objective.

**OBJECTIVE 4.1**  
**CONTACT INTERACTIONS AND ENERGY (Grades 5-8 and Grades 9-12)**

*Students understand that a mechanical energy transfer (work) across the boundary of a system can change the kinetic energy, stored elastic energy, thermal energy, chemical energy, or other types of energy stored within the system.*

**Elementary Foundations**

By the end of grade 4, students should know:

1. The way to change how something is moving is to give it a push or a pull. [BSL 4F/P2]
2. Changes in speed or direction of motion are caused by forces. [BSL4F/E1a]
3. The greater the force is, the greater the change in motion will be. The more massive an object is, the less effect a given force will have. [BSL 4F/E1bc]

**Grades 5 - 8**

**Clarification.** Students begin to develop fluency in qualitatively describing contact interactions in terms of a mechanical energy transfer (work) from one object, the energy source, to the interacting object, the energy receiver. Students are also introduced to four methods of energy storage by objects; motion (kinetic) energy; thermal energy, elastic energy, and chemical energy.

**RELATED OBJECTIVES:** Interactions, Systems, and Scale (1.1); Conservation of Mass, Energy, and Charge (2.1); Contact Interactions and Forces (3.3); Heating and Cooling Interactions and Energy (4.5)

**BOUNDARY:**<sup>1</sup> *Problems are limited to events involving horizontal, one-dimensional contact interactions (see Objective 5.2 for gravitational interactions and energy). All other simultaneous interactions should be negligible. Excluded are situations that require Newton's third law, such as a person who is walking or a moving car. The term "work" is not used until grades 9 - 12 because of the conceptual difficulties students have using this term.*

**ESSENTIAL KNOWLEDGE\***

Students reason with and apply the following concepts in the learning outcomes:

**M.4.1.2** During an interaction between two objects or systems, energy is transferred from one system (energy source) to the interacting system (energy receiver). The energy of the source decreases and the energy of the receiver increases. There are different methods of energy transfer. [SSCS, pages 103-104]

**M.4.1.2** Mechanical energy transfer occurs when one object (energy source) pushes or pulls another object (energy receiver). The amount of mechanical energy transfer during an interaction depends on the strength of the force (the greater the force, the larger the energy transfer) and the distance the force acts (the greater the distance, the larger the energy transfer).

**M.4.1.3** A useful analogy (analogue model) for the energy of objects or systems is: Just as material objects are kept stored in containers, energy is "stored" in physical and chemical systems. The different methods of energy storage in a physical system are associated with different observable *changes* that can indicate an increase or decrease of the stored energy when energy is transferred into or out of the system.

**M.4.1.4** There are different methods of storing energy in objects/systems.

- a. Energy can be stored in elastic objects, such as rubber bands or springs. The elastic energy of an object *changes* when it is stretched or compressed.

<sup>1</sup> For further background and instructional guidance, including restrictions in the scope of the content for the learning outcomes, see the objective chart in Instructional Guidance for Standard 4.

\* For further clarification of the learning outcomes and essential knowledge statements, see the objective *Table of Common Student Conceptual Difficulties* in Instructional Guidance for Standard 4.

## Guide to Using the College-ready Physics Standards (continued)

Each essential knowledge statement has its own unique code with the letter indicating the grade level band (middle school or high school), and the first two numbers are the standard and objective number.

### ESSENTIAL KNOWLEDGE 5-8, continued

- b. Energy can be stored in the motion of objects. Motion (kinetic) energy *changes* when an object's speed changes. [SSCS, page 104]
- c. Energy can be stored in a system of chemicals. The chemical energy of a system *changes* when the chemicals are allowed to react and new substances are produced.
- d. Energy can be stored because objects have a temperature and state (solid, liquid, or gas). The thermal energy of an object *changes* when its temperature or state changes.

**M.4.1.5** The oxygen we breathe reacts chemically with digested food in the blood in our muscles (food-oxygen subsystem in humans)<sup>1</sup> when the muscles are used to push or pull on an object and move it some distance. After the push or pull (force) has stopped, the human body has less food in the food-oxygen subsystem, and the chemical energy of the human decreases.

A **Learning Outcome** specifies what students should know, understand and be able to do in order to meet the overall goal of depth of conceptual understanding of the objective. They also illustrate the types of tasks in which students can engage to build their understanding of the objective.

### LEARNING OUTCOMES

Ways in which students engage with and apply the essential knowledge in order to understand the objective:

- Represent, verbally and with a diagram, the energy source, energy receiver, and the direction of energy transfer in simple contact interactions or a chain of interactions (i.e., the object that is energy receiver of first interaction is energy source for second interaction, and so on).  
[**BOUNDARY:** Representations do not need to include the type of energy transfer or the changes in the stored energy of the source or receiver.]
- Investigate the variables that influence the amount of mechanical energy transfer in different real-world situations involving a contact interaction (e.g., the strength of the force; the distance the force acts):
  - ◆ Identify the energy source and the energy receiver. Predict how changing the variable will influence the amount of mechanical energy transfer.
  - ◆ Decide how you will determine the change in the energy transfer (more, less or the same).
  - ◆ Gather data and record observations.
  - ◆ Make a claim about how the variable influences how much energy is transferred during the interaction.
- Analyze simple, real-world situations involving contact interactions between two objects defined as a system. (a) Observe changes in each object during the interaction. (b) Make claims about the direction of the energy transfer and energy changes within the system. Justification is based on observations and knowledge of mechanical energy transfer and the characteristics of the different methods of storing energy. (c) Construct an energy diagram for the interaction.
- Give real-world examples of mechanical energy transfers that result in a change in the motion (kinetic) energy, elastic energy (e.g., stretched rubber band or compressed spring), thermal energy (e.g., baseball player sliding to home base), or chemical energy (e.g., a human pushes or pulls on an object) of the energy source or receiver.
- Analyze, and represent with energy diagrams, different real-world situations that involve a *chain of contact interactions* and mechanical energy transfers. Justification is based on observations of changes and knowledge of mechanical energy transfer and the characteristics of the different methods of storing energy.

**Boundary** statements provide instructional guidance by restricting the scope of the content.

<sup>1</sup> The level of sophistication of this knowledge depends on what students have previously learned about respiration in their life science classes.



## STANDARD 1 INTERACTIONS, SCALE, AND MODELS

*Changes in the natural world are the result of interactions. The description, explanation, and prediction of interactions depend on the size and time scale and our models of the structure of matter. For objects moving very fast, the macro (human) scale ideas of absolute time and space must be revised.*

Students understand that at the macro (human) scale\* (length and time larger than about  $10^{-6}$  and smaller than about  $10^{+10}$ ) descriptions, explanations, and predictions of the changes that occur during all events (simple interactions, multiple simultaneous interactions, and complex interaction chains) depend on defining a time interval and a system of interest. Macro-scale objects are identified by their properties – how they interact with our senses or measuring instruments, and the substances that make up objects are identified by unique sets of properties.

Different mental models are useful at the atomic scale ( $\sim 10^{-10}$  m) and subatomic scale ( $\leq 10^{-15}$  m). At the atomic scale, the small-particle model of matter is a useful for explaining the physical properties of substances, such as the state (solid, liquid, or gas) of a substance at room temperature. At the core of this model is the idea that the strength of the attraction between the particles (atoms and molecules) of a substance is different for different substances, ranging from very weak to strong. The atom consists of electrons, protons, and neutrons, and the physical and chemical properties of elements depend on the number of protons in the nucleus and the configuration of its electrons. At the subatomic scale, the quantum mechanical model is useful for describing, explaining and predicting the interaction of subatomic particles with macro-scale objects, including measuring instruments.

At the scale of the nucleus ( $\sim 10^{-15}$  m), the force that holds the protons and neutrons together in the nucleus is much stronger than the electric force that holds the electrons and nucleus together in the atom. Consequently, much larger amounts of energy can be transferred out of a system during nuclear interactions than during chemical interactions, which only involve the outermost electrons of an atom or molecule.

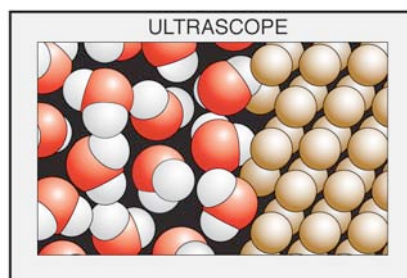

Interface between water and a metal.

### **Objective 1.1: Interactions, Systems, and Scale** (Grades 5-8)

*Students understand that observed changes in our world are the result of interactions. The description, explanation, and prediction of interactions depend on the defined system and defined time interval, and the distance and time scale involved [cosmic, macro (human), and the atomic and subatomic domains of magnitude].*

### **Objective 1.2: Interactions and Properties** (Grades 5-8)

*Students understand that at the macro (human) scale, the properties of objects are qualitative or quantitative descriptions of how the object interacts with other objects or systems. Properties that do not depend on the amount of material can be used to identify the material.*

### **Objective 1.3: Interactions and Atomic and Subatomic Models** (Grades 5-8 and 9-12)

*Students understand that different mental models are useful at the atomic scale (small particle model of matter) and subatomic scale (quantum mechanics) for describing, explaining and predicting events, processes, and the properties of systems.*

### **Objective 1.4: Interactions and Objects Moving Very Fast** (Grades 9-12)

*Students understand that the Newtonian ideas about absolute space and time are incorrect, as Einstein demonstrated with his special theory of relativity.*

\* Underlined words and phrases are defined in the glossary.



## OBJECTIVE 1.1 INTERACTIONS, SYSTEMS, AND SCALE (Grades 5-8)

*Students understand that observed changes in our world are the result of interactions. The description, explanation, and prediction of interactions depend on the defined system and defined time interval, and the distance and time scale involved [cosmic, macro (human), and the atomic and subatomic domains of magnitude].*

*Clarification.* The ideas in this objective are used throughout physics in both the grades 5 - 8 and grades 9 - 12. When considering any type of qualitative or quantitative problem, one defines the time interval, the system of interest, including boundaries, and identifies interactions within the system and between the system and its surroundings.

### Elementary Foundations

By the end of grade 4, students know that:

1. An object can change in various ways, such as in size, weight, color, or temperature. Some features of things may stay the same even when other features change. [BSL 11C/P3a\*]
2. People can keep track of some things, seeing where they come from and where they go. [BSL 11C/P2]
3. In things that are made up of many parts, the parts usually influence one another. [BSL 11A/E1]
4. Something may not work well (or at all) if a part of it is missing, broken, worn out, mismatched, or misconnected. [BSL 11A/E2]

### Grades 5 - 8

*Clarification.* Students are introduced to the central theme of interactions and to the idea that the description of an event can be different for different systems of interest and/or time intervals. This idea is developed further in Objective 1.2. Students are also introduced to domains of magnitude of size and time. [Note: Interactions and systems of interest can be introduced in grades 5 - 6. Consideration of distance and time scales should be introduced in later grades 7 - 8.]

**BOUNDARY.**<sup>†</sup> *Events are limited to simple, everyday activities. System inputs and outputs should be limited to materials unless energy has been introduced (see Standard 4).*

### ESSENTIAL KNOWLEDGE\*

Students know, apply, and reason with the following concepts in the learning outcomes:

- M.1.1.1** Scientists describe and explain observed changes in terms of interactions. Two objects (which can be a defined quantity of a solid, liquid or gas) interact when they act on or influence each other to cause some effect. The evidence of the interaction is usually the effect -- an observed change in one or both objects (e.g., change in the motion, change in properties such as mass, volume, temperature, shape, and texture).
- M.1.1.2** Sometimes an event or process involves a single interaction between two objects; sometimes it involves complex chains of interactions and/or multiple simultaneous interactions. Some events are very short, while others are very long.
- M.1.1.3** Scientists use the concept of a *system* to help in their study of processes and events. By defining a system of interest and a time interval, any inputs, outputs, and changes within the system can be tracked. A real boundary (e.g., surface of cup) or an imaginary boundary (e.g. food-oxygen system in humans) separates the system of interest from the surroundings. The system of interest can be a single object, two interacting objects, or a larger system with subsystems (e.g., car-engine system).

<sup>†</sup> For further background and instructional guidance, including restrictions in the scope of the content for the learning outcomes for each objective, see Instructional Guidance for Standards 1 (page 77).

\* For further clarification of the essential knowledge statements and learning outcomes for each objective, see the *Tables of Common Student Conceptual Difficulties* in Instructional Guidance for Standard 1.



- M.1.1.4** The interaction description of the same event is different for different defined systems and/or time intervals.
- M.1.1.5** A closed (isolated) system does not interact with its surroundings: materials and energy cannot get into or out of the system. Most systems of interest in our everyday lives are open systems. Materials and energy can be transferred into or out of the system. [SSCS, page 101]
- M.1.1.6** When defining time intervals and systems of interest, it is convenient to think about three *domains of magnitude* in size (distance in meters) and time (in seconds); the macro (human) domain, the cosmic domain, and the atomic and subatomic domains.<sup>1</sup>
- The macro (human) domain (distance and time larger than about  $10^{-6}$  and smaller than about  $10^{+10}$ ) corresponds roughly with what can be perceived and measured with either human senses or simple instruments (e.g., optical microscopes and telescopes).
  - The cosmic domain (distance and time larger than about  $10^{+10}$ ) is so great it is almost beyond imagination, and requires instruments or procedures that depend on long chains of reasoning to understand how they work.
  - Similarly, the atomic and subatomic domains (distance and time  $< 10^{-6}$  and  $< 10^{-14}$  respectively) are tiny beyond imagination and it requires a great deal of physics knowledge to understand the measurement instruments.

## LEARNING OUTCOMES

Ways in which students engage with and apply the essential knowledge in order to understand the objective:

- Represent simple events, in words and/or diagrams, by identifying the interacting objects/systems (or a successive chain of interactions between pairs of objects) and the evidence of these interactions for a defined system and time interval.
- Give examples of systems that consist of subsystems; identify the objects in the subsystems.
- Recognize when the interaction description of the same event is different for different defined systems and/or time intervals.
- Analyze simple mechanical devices in terms of interactions and evidence of interactions, system and subsystems, boundaries, and inputs and outputs. Describe what the various parts are for; estimate (predict) what the effect of making a change in one part of a device would have on the device as a whole.
- Define the time interval and system of interest for a study, including subsystems, the boundaries of the system, the objects in the surroundings that interact with the system of interest, and the inputs and/or outputs of the system during the defined time interval. Justify the usefulness of a choice of a system for the convenience of the study.
- Gives examples of objects or events to add to a chart that shows three domains of magnitude of size and time: atomic and subatomic, macro (human), and cosmic.
- Express numbers like 100, 1,000, and 1,000,000 as powers of ten. [BSL 12B/M9]

## Grades 9 - 12

None. Learning outcomes and essential knowledge of interactions, systems, and scales are included in other standards and objectives at the grades 9 - 12 level.

<sup>1</sup> The idea of domains of magnitude came from Robert Karplus's book *Interactions: A Model Approach* (1969, 2003)

## OBJECTIVE 1.2

### INTERACTIONS AND PROPERTIES (Grades 5-8)

*Students understand that at the macro (human) scale, the properties of objects are qualitative or quantitative descriptions of how the object interacts with other objects or systems. Properties that do not depend on the amount of material can be used to identify the material.*

#### Elementary Foundations

By the end of grade 4, students know that:

1. People use their senses to find out about their surroundings and themselves. Different senses give different information. [BSL 6D/P1\*]
2. Objects can be described in terms of their properties. Some properties, such as hardness and flexibility, depend upon what material the object is made of, and some properties, such as size and shape, do not. [BSL 4D/P1\*]
3. All materials have certain physical properties, such as strength, hardness, flexibility, durability, resistance to water and fire, and ease of conducting heat. [BSL 4D/E6\*\* (SFAA)]
4. Length can be thought of as unit lengths joined together, area as a collection of unit squares, and volume as a set of unit cubes. Areas of irregular shapes can be found by dividing them into squares and triangles. [BSL 9C/E1]  
Volumes of irregular shapes can be estimated by building the same shape from unit cubes.
5. Measuring instruments (e.g., clocks, stopwatches, rulers, tape measures, unit squares and cubes, simple balances) can be used to gather accurate information for making scientific comparisons of objects and events and for designing and constructing things that will work properly. [BSL 3A/E3]
6. Air is a material that surrounds us and takes up space and whose movement we feel as wind. [BSL 4B/E4\*]

#### Grades 5-8

*Clarification.* Students begin to develop their skills in precise and accurate measurement (including measurement errors) of the properties of objects. They recognize properties that do not depend on the amount of the substance

**RELATED OBJECTIVES:** Conservation of Mass, Energy and Charge (2.1); College Board *Standards for College Success: Mathematics and Statistics* MI.3.1 and MII.3.3.

**BOUNDARY:**<sup>†</sup> See *Boundary conditions for the learning outcomes in the Instructional Guidance for Standard 1 (pages 79-80).*

#### ESSENTIAL KNOWLEDGE

Students reason with and apply the following concepts in the learning outcomes:

- M.1.2.1** A property of an object is a description, qualitative or quantitative, of how the object interacts with other objects (e.g., magnetic materials are materials that are attracted to a magnet).
- a. In our everyday life, properties of objects are descriptions of how the objects interact with our senses.
  - b. The interaction of an object with a measuring instrument (e.g., ruler, thermometer, graduated cylinder, mass balance) provides more reliable information about an object's properties than our senses alone.
  - c. A pure substance has a unique set of properties (e.g., melting point, boiling point, density, color, hardness, thermal conductivity) that can be used to identify it. Under all conditions, these properties do not depend on the amount (mass or volume) of the substance. [SSCS, page 97]
- M.1.2.2** Volume and mass are two different properties of objects that help us determine the amount of material in an object (e.g., How much mayonnaise is in this jar?).
- a. The volume of an object is the number of standard unit cubes that fit inside the object. Volume tells us how much room or space an object takes up. Standard units of volume are cubic centimeters (cm<sup>3</sup>), cubic

## ESSENTIAL KNOWLEDGE (5-8), continued

- meters ( $m^3$ ), milliliters (ml), and liters (l). There are different methods of counting the number of unit cubes that fit inside the object.
- b. The mass of an object is the number of standard unit masses that balance the object on a mass balance. Standard units of mass are the gram (g) and kilogram (kg).<sup>2</sup>
- M.1.2.3** Different gases have different properties, but all gases have volume and mass.] The air in our atmosphere is a mixture of different gases, including oxygen (~20%), nitrogen (~79%), and trace amounts of water vapor, carbon dioxide, and other gases (~1%).
- M.1.2.4** When measurements are performed, a true (or exact) value is never obtained; there is always some uncertainty associated with a measurement. [SSCS, page 97]
- a. An uncertainty ( $\pm$  measurement error) should be estimated and reported with each measured value. Estimations depend on the precision of the instrument (e.g.,  $20.5 \pm 0.5$  °C).
- b. A quantity should be measured several times (trials) and the average (mean) calculated. There is always some variation in measured values. An uncertainty should be estimated and reported with the average (e.g., 105.4 grams  $\pm$  2 grams).
- M.1.2.5** The density of any object can be measured and calculated by dividing the mass of the object by the volume of the object ( $D = M/V$ ). For objects made of a (pure) uniform substance, density is the mass of each unit volume of the substance, and is the same for all samples of the substance. Density is different for different substances.

**LEARNING OUTCOMES**

Ways in which students engage with and apply the essential knowledge in order to understand the objective:

- Give real-world examples of how instruments are better than using our senses to make scientific observations (e.g. temperature, density, mass, volume).
- Draw interaction chains for determining different properties of objects.
- Measure time intervals, lengths, surface areas, mass, and temperature of different objects, estimate the measurement errors, and report each value with its measurement error (e.g., 105.4 grams  $\pm$  1.7 grams).
- Measure, using different methods, the volume of gases and liquids, the inside volume of solid containers, and the volume of regular and irregular solid objects; estimate the measurement errors and report the value and the measurement error. [SSCS, page 96]
- Investigate the relationship between the mass and the volume of different substances. (a) Develop an appropriate method of measuring the mass and the volume of different amounts of a substance. (b) Record measurements of the mass and the volume of different amounts of the substance, and organize this data in a table with estimated measurement errors. (c) Construct a graph, using collected data, to show the relationship between mass and volume, and find a best-fit representation. (d) Use the relationship between mass and volume to define density. Calculate the density of the substance. (e) Compare the densities of different substances. Explain why density can be used to help identify an unknown substance.
- Calculate the mass of different objects by using a given value of volume or measuring the volume, and using the mathematical relationship for density and a table of densities. Similarly, calculate the volume of different objects by using a given value of mass or measuring the mass, and using the mathematical relationship for density and a table of densities. [SSCS, page 96]
- Describe a substance in terms of its properties (e.g., temperature, state, density, thermal conductivity, color, hardness and magnetic properties). Identify which properties of a substance are dependent on the amount of the sample and which are not. [SSCS, page 96]

<sup>2</sup> Only gravitational mass is used in these standards. The distinction between gravitational and inertial mass is a college-level topic.

## LEARNING OUTCOMES (5-8), continued

- Identify unknown but familiar substances from descriptions of sets of properties of the unknown substances (including melting or boiling temperatures and density), using knowledge of substances, a table of densities, and a table of melting and boiling temperatures.
- Give examples of evidence that supports the idea that gases have mass and volume, and different gases (e.g., oxygen, nitrogen, hydrogen, carbon dioxide) have different properties. [SSCS, page 96]

## Grades 9-12

The quantitative measurement of properties in the grade band 9-12 are embedded in the other objectives.

### OBJECTIVE 1.3

#### INTERACTIONS AND ATOMIC AND SUBATOMIC MODELS (Grades 5-8 and Grades 9-12)

*Students understand that different mental models are useful at the atomic scale (small particle model of matter) and subatomic scale (quantum mechanics) for describing, explaining and predicting events, processes, and the properties of systems.*

*Clarification.* In grades 5 - 8, students are introduced to the small-particle model of substances (matter). They begin to develop fluency in using the model to explain different physical properties of room temperature gases, liquids, and solids. Students in grades 9 - 12 are introduced to some qualitative ideas in quantum mechanics.

### Elementary Foundations

By the end of grade 4, students know that:

1. Science is a process of trying to figure out how the world works by making careful observations and trying to make sense of those observations. [BSL 1A/E2\*\*] Scientists' explanations about what happens in the world come partly from what they observe, partly from what they think. [BSL1B/E3a]
2. A model of something is similar to, but not exactly like, the thing being modeled. Some models, like toys, are physically similar to what they are representing, but others are not. [BSL 11B/P]
3. Geometric figures, diagrams, sketches, number sequences, graphs, number lines, maps, and oral and written descriptions can be used to represent objects, events, and processes in the real world. [BSL 11B/E2\*]
4. Representations and models are very useful for communicating ideas about objects, events, processes, and interactions. When using a representation or model to communicate about something, it is important to keep in mind how it is different from the thing being represented or modeled. [BSL 11B/E4\*]
5. Materials may be composed of parts that are too small to be seen without magnification. [BSL4D/E3]

## Grades 5 - 8

*Clarification.* In grades 5 - 8, the nature of the interaction forces between the particles in the small-particle model is not specified, but if students have already studied electrical forces (Objective 3.4) the fact that this force is electrical in nature can be discussed.

**RELATED OBJECTIVES:** Contact Interactions Forces (3.3); Heating and Cooling Interactions and Energy (4.5)

### ESSENTIAL KNOWLEDGE

Students reason with and apply the following concepts in the learning outcomes:

- M.1.3.1** Collections of small pieces (sand, powders, marbles, sugar cubes) may have properties that the individual pieces do not. [BSL4D/E7\*\* (ASL)]
- M.1.3.2** Scientists find it useful to compare a new idea about a system, process, or event with something that is familiar. The thing that is familiar is called an analogue model of the system, process, or event. Analogue models can be physical (e.g., small model car in wind tunnel), verbal, and/or visual. [Same as in Objective 2.1]
- M.1.3.3** Theories often make use of a set of related ideas that are simplified and idealized – without the complexities of the full theory. This set of simplified, idealized ideas is a mental model.
- M.1.3.4** All models have some similarities but also some differences from the real thing. Deciding what kind of model to use depends on its purpose: (1) to help us initially make sense of (understand) the ideas in a mental model, or (2) to help us figure out how a system or process works. A model is considered useful when the difference(s) between the model and the things they represent are not important *for the purpose of the model*.
- M.1.3.5** A useful mental model of substances (gas, liquid, or solid) that helps us make sense of the physical properties of substances is:
- Substances are made up of a huge number of very tiny particles (atoms or molecules). The particles are too small to see with a visible-light microscope.
  - All particles of a (pure) substance have identical mass, volume, and shape, but are different from the particles of all other substances.
  - There is nothing between the particles of a substance (the space is empty of stuff).
  - The particles move continually in all directions with a large range of speeds.
  - The interaction between the particles of a substance is an attraction when they are relatively far apart, and a repulsion when very close during collisions.
  - The strength of the attractive forces between particles is different for different substances, ranging from very weak to strong.
- M.1.3.6** The small-particle idea that the strength of the attractive forces between particles is different for different substances helps us explain many physical properties of materials, including *why different substances are a gas, liquid, or solid near room temperature*.
- When the attractive forces between the particles of a substance are *very weak* (almost none), then the substance is usually a gas near room temperature. Consequently, the particles move (almost) *independently* in all directions with a large range of speeds, and on the average, are far apart compared to the size of the particles. The average speed of the particles of air between collisions is about the speed of sound (about 770 miles per hour) at room temperature.
  - When the attractive forces between the particles of a substance are weak to medium, then the substance is usually a liquid near room temperature. In a liquid, the attractive forces are strong enough to keep the particles clumped close together, but weak enough so the particles can bump and slide past each other.
  - When the attractive forces between the particles of a substance are *strong*, then the substance is usually a solid near room temperature. In a solid, the attraction is strong enough so that the particles can only vibrate back and forth about (relatively) fixed positions.

## LEARNING OUTCOMES

Ways in which students engage with and apply the essential knowledge in order to understand the objective:

- Investigate and compare, qualitatively, several properties of room temperature solids, liquids, and gases (e.g., shape, volume, how easy they are to pull apart [tensile strength], how easy they are to compress).
- Give real-world examples of collections of small pieces (e.g., sand, powders) that have properties that the individual pieces do not have. From collections of small pieces, construct physical analogue models of the small-particle explanations of the shape and volume properties of liquids and solids. Explain how the physical model is the same as and different from the small particle model ideas.

## LEARNING OUTCOMES (5-8), continued

- Rank the strength of the attractions between the particles of three room-temperature (pure) substances (a solid, a liquid and a gas) in order from greatest to least. [SSCS, page 99]
- Give examples of objects to add to a chart that shows the atomic and part of the macro (human) size scale (about  $10^{-10}$  m to  $10^{+3}$  m). Investigate the range in sizes that can be seen with the unaided eye, a visual light microscope, and instruments like the electron microscope.
- Recognize when different visual representations of an idea in the small-particle model of gases, liquids, and/or solids are good or poor for the purpose of helping us understand the model idea. When appropriate, revise the visual representation.
- Recognize when small-particle explanations of different physical properties of room temperature gases, liquids, and solids are good or poor, using the criteria: (a) the explanation links the macroscopic property of the gas, liquid, or solid to the relevant small-particle model idea(s); (b) the explanation is based on the correct small-particle model idea(s), and (c) the explanation is complete (no important small-particle model ideas are missing from the explanation).
- Explain why solids, liquids and gases have different physical properties (e.g., thermal expansion, how easy they are to compress) at room temperature. Justification is based on the small-particle model of substances.

## Grades 9 - 12

*Clarification.* While some quantum mechanics ideas are abstract and rigorous, the purpose of this objective is not deep understanding at the level of manipulating probability functions. The purpose is to leave students with the modern view that photons and subatomic particles do not have wave-like or particle-like properties – it is the probabilities that are wavelike.

**RELATED OBJECTIVES:**  
Mechanical Wave  
Interactions and Energy (4.3);  
Radiant Energy Interactions  
(4.4).

**BOUNDARY.<sup>†</sup>** Excluded are the historical wave-particle duality arguments, the uncertainty principle, and de Broglie's wavelength.

## ESSENTIAL KNOWLEDGE

Students reason with and apply the following concepts in the learning outcomes:

- H.1.3.1** All atoms consist of three subatomic particles, called protons, neutrons, and electrons. Atoms are mostly empty space. Essentially all of the mass of the atom is in a tiny, dense center or *nucleus* of the atom, which contains positively charged protons and neutral neutrons, which have almost the same mass. Electrons are much lighter than the other subatomic particles, are negatively charged, and are within the empty space that surrounds the nucleus. The electron and proton have equal but opposite charges. In neutral atoms, the number of protons is the same as the number of electrons.
- H.1.3.2** Electrons in an electron-rest of atom system have definite energy levels, with no values in between. Electrons usually occupy the lowest available energy levels (ground state). When an electron moves from one energy level to another, the electron-rest of atom system emits or absorbs a photon that has energy equal to the energy difference between the levels. The energy levels of electrons are different for each element. Consequently, each element has a unique emission spectrum or absorption spectrum. [SSCS, Chemistry, page 116]
- H.1.3.3** The theory called quantum mechanics describes, explains, and predicts subatomic interactions. The quantum mechanical consequences of these interactions are sometimes directly visible on the human scale. In quantum mechanics, *interactions* can be modeled as particle-like or wave-like, depending on the number of ways that the interaction can happen. The evidence for these models includes:
- a. Experiments with light interacting with single or double slits that result in a diffraction pattern or two-source interference pattern, which are characteristic of the interaction of mechanical waves with slits.
  - b. Experiments with light interacting with metals (photoelectric effect), which result in data patterns characteristic of the interaction of objects (called photons) with discrete energies interacting with other

## ESSENTIAL KNOWLEDGE (9-12), continued

objects (electrons of the electron-rest of metal atom system);

- c. Experiments with electrons interacting with crystals (whose atomic structure acts like slits) resulting in diffraction or interference patterns, which are characteristic of the interaction of mechanical waves with slits; and
- d. Experiments with high-energy particles interacting with materials that result in data patterns characteristic of the interaction of discrete objects.

**H.1.3.4** At the macro (human) scale, the properties<sup>3</sup> of an object are descriptions of how the object interacts with other objects, including measurement instruments, and it appears that the effect of the measuring instrument is insignificant. On the other hand, the properties of objects are among the quantities that define interactions (e.g., charges and masses are part of force laws and energy equations). This paradox causes no difficulty until we reach the scale of very small “objects,” like electrons and photons. At this scale, the presence of measurement instruments changes the result of an interaction. We cannot ask questions such as: which slit did the particle (e.g., electron or a photon) go through? We cannot determine precisely both the momentum and the position of an object at the same time. All we can calculate are probabilities.

**H.1.3.5** A simplified quantum mechanical mental model of interactions is that there is a set of rules for adding up the probabilities of all possible paths a particle (e.g., photon, electron, or other subatomic particle) could follow from one location to another. The probabilities have the same mathematical form as a wave that changes with time.

- a. Sometimes the probabilities add in such a way that the final location of a particle is the same as predicted from classical mechanics (e.g., light travels in straight lines, the laws of reflection and the refraction of light).
- b. Sometimes the sum of probabilities result is a probability “cloud” for the final location of the subatomic particle. The thicker the probability cloud, then the more likely (probable) it is to find the subatomic particle at that location at any given time. The thinner the cloud, then the less likely it is to find the particle at that location at any given time. For the two-slit experiment, the probability cloud for a photon or electron is the same as the observed interference pattern.
- c. The electrons in an atom do not orbit the nucleus. The sum of the probabilities for the location of a specific electron in an atom is a probability cloud (called an *orbital*). The shape of the probability cloud differs for different electrons in an atom.

**H.1.3.6** There are pairs of quantities that can be measured and obtained individually, but never at the same time (e.g., momentum and position, energy and time). You can know one precisely, but then you will know nothing about the other and vice versa. This is called the principle of complementarity.

**H.1.3.7** Light and subatomic particles are not particles at one time and waves at another, nor do they have innate particle-like and/or wave-like properties. They are neither particles nor waves. An analogy for quantum mechanics is the flight of a baseball. The path of the baseball is not due to an innate “ballness” property; the path depends of the interactions of the ball with its surroundings (the air and the Earth), and is different in different surroundings (i.e., in the space station). Similarly, the path of an electron (or photon or other subatomic particle) does not depend on whether the electron is a particle, a wave, or something else. The path depends on the interaction of the electron with its surroundings, including measurement instruments. The path of a particle to some final location is described in terms of a set of rules for interactions – classical mechanics “rules” or laws for the baseball, and quantum mechanics rules for summing probabilities for subatomic particles.<sup>4</sup>

## LEARNING OUTCOMES\*

Ways in which students engage with and apply the essential knowledge in order to understand the objective:

<sup>3</sup> At this level, students do not need to develop a deeper understanding of the meaning of the properties of subatomic particles (e.g., color, strangeness, and so on).

<sup>4</sup> The flight of a baseball analogy is an adaptation of a personal communication from Ken Heller.



## LEARNING OUTCOMES (9-12), continued

- Compare and contrast the mass, charge and location of protons, neutrons and electrons in an atom. [SSCS, page 155]
- Explain, using absorption and emission spectra, how this evidence supports the idea that electrons have discrete energy levels. Justification includes the use of analogue models and visual representations, and a discussion of how emission and absorption spectra arise, why these spectra are unique to each element, and how these spectra are limited to a set of discrete energies. Compare the spectra of elements to standard spectra in order to identify elements in stars. [SSCS, Chemistry, page 115]
- Justify, based on evidence, the particle model and the wave model of *interactions* of light and subatomic particles with macro (human) scale objects and instruments.
- Compare the effect of a measuring instrument on the results of an interaction at the macro (human) scale and at the subatomic scale.
- Identify, from different pictures of a probability cloud, the regions where a photon or electron is most likely to be found, and justify using knowledge of probability clouds.
- Explain why we cannot say that light and electrons are sometimes particles and sometimes waves, or that they each have both wavelike and particle-like properties. Justification is based on knowledge of the quantum mechanical model of interactions with subatomic particles.

## OBJECTIVE 1.4

### INTERACTIONS AND OBJECTS MOVING VERY FAST (Grades 9 - 12)

*Students understand that the Newtonian ideas about absolute space and time are incorrect, as Einstein demonstrated with his special theory of relativity.*

*Clarification.* The knowledge about the special theory of relativity is conceptual and limited to a few consequences of relativity (time dilation, length contraction, addition of velocities, and space-time). The purpose is not deep understanding of relativity, but an introduction to a different way of thinking about space and time

**RELATED OBJECTIVES:**  
Interactions, Forces, and Motion (3.2). Forces and Fields (5.1)

**BOUNDARY.**<sup>†</sup> *Evidence is limited to historical experiments for time dilation and length contraction.*

### ESSENTIAL KNOWLEDGE

Students reason with and apply the following concepts in the learning outcomes:

- H.1.4.1** While Newton's laws of motion, including the universal law of gravitation, can be used to explain and predict many physical events and have many practical applications, they are not correct for objects traveling near the speed of light. In these cases, Einstein's special theory of relativity must be applied.
- H.1.4.2** Newtonian physics is based on the assumption that space and time are absolute and independent. Newton assumed that space itself is a fixed (stationary) reference frame from which all motion can be determined absolutely, and time is constant, progressing at a fixed rate at all locations in space.
- H.1.4.3** Einstein's special theory of relativity overthrows Newtonian notions of absolute space and time, although the effects are only noticeable for objects moving very fast -- a significant fraction of the speed of light. The theory is based on two postulates:
- a. *The Principle of Relativity.* The laws of physics are the same in all uniformly moving coordinate systems (inertial frames of reference). So there is no absolute time or motion.



## ESSENTIAL KNOWLEDGE (9-12), continued

- b. *The Constancy of Speed of Light in Vacuum.* The speed of light in vacuum has the same value  $c$  in all uniformly moving coordinate systems. So there is no coordinate system that is at absolute rest.

**H.1.4.4** The consequences of the special relativity postulates have been experimentally verified (including the Michelson-Morley experiment). For example:

- a. When an object (with mass) is in motion, the passage of time, measured with a clock (including a biological clock like pulse rate), is slowed. Only a person that is in a different frame of reference from the object would be able to detect the slowing of time - as far as the object is concerned, in its frame of reference, the passage of time is the same. This phenomenon is referred to as time dilation.
- b. When an object (with mass) is in motion, its measured length shrinks in the direction of its motion. Only a person that is in a different frame of reference from the object would be able to detect the shrinking - as far as the object is concerned, in its frame of reference, its size remains the same. This phenomenon is referred to as length contraction.
- c. Relative velocities of uniformly moving observers never exceed the speed of light. For example if a rocket is moving at  $2/3$  of the speed of light relative to an observer, and the rocket fires a missile at  $2/3$  of the speed of light relative to the rocket, the missile does not exceed the speed of light relative to the observer.
- d. Time cannot be separated from space because the *rate at which time passes depends on an object's velocity relative to the speed of light*. The concept of space-time combines space and time within a single coordinate system, typically with 4 dimensions: length, width, height, and time. The space-time coordinate grid is used to locate "events" rather than just points in space.

## LEARNING OUTCOMES

Ways in which students engage with and apply the essential knowledge in order to understand the objective:

- Investigate the experimental evidence for time dilation, length contraction, and/or the rules for the addition of velocities in special relativity. Explain how the evidence supports the theory.
- Explain why a stationary observer measures the light clock in a fast-moving system as running slow. Justification includes appropriate diagrams of what an observer in the moving system measures and what the stationary observer measures.
- Explain why a stationary observer measures the distance between objects in a fast-moving system as shorter. Justification includes appropriate diagrams of what an observer in the moving system measures and what the stationary observer measures.
- Evaluate explanations of special relativity as good or poor based on the criteria: (a) the explanation links the evidence to the statement in the explanation; (b) the explanation is based on the correct special relativity idea(s); (c) the explanation is complete (no important special relativity ideas are missing from the explanation); and (d) the explanation is logical.
- Describe the difference between Newtonian space and time and relativistic space-time, using the consequences of the special theory of relativity.



## STANDARD 2 CONSERVATION PRINCIPLES

*The interaction of one object with another object is governed by a few conservation principles. These principles are considered fundamental because they apply to interactions at all time and size scales and cannot be derived from other theories.*

All interactions, at all size and time scales, are governed by conservation principles. A quantity is “conserved” when the total quantity does not change as the universe evolves. Therefore in an open system, any change in the quantity represents a transfer of the quantity into or out of the system. Mass and energy are conserved separately, within measurement errors, at the macro (human) time and size scales. The conservation of charge, mass-energy, and linear momentum are fundamental principles of science because they apply to interactions at all size and time scales and they cannot be derived from other theories. All scientific theories must be consistent with these conservation principles.

### **Objective 2.1: Conservation of Mass, Energy, and Charge** (Grades 5-8 & 9-12)

*Students understand that at the macro (human) and atomic scales, mass and energy are conserved separately, within measurement errors, for all types of interactions and defined systems (open or closed). Charge is always conserved at all scales.*

### **Objective 2.2: Conservation of Linear Momentum** (Grades 9-12)

*Students understand linear momentum is conserved at all size and time scales, and for all types of interactions and defined systems (open or closed).*

### **Objective 2.3: Nuclear Interactions and the Conservation of Mass-Energy** (Grades 9-12)

*Students understand that nuclear interactions result in product particle(s) with less mass than the original particle(s); the missing mass appears as an energy transfer out the system. Mass-energy is conserved at all size and time scales, for all types of interactions, and for all defined systems (open or closed).*

**CLARIFICATION.** The physics standards use the conservation principle<sup>❖</sup> (sometimes called the continuity principle) as a central idea to organize and understand the interactions between objects and systems. The conservation principle for a quantity is: The total change of the quantity ( $Q$ ) within a system ( $\Delta Q_{\text{system}}$ ) is equal to the quantity transferred out of the system subtracted from the quantity transferred into the system ( $Q_{\text{in}} - Q_{\text{out}}$ ).



<sup>❖</sup> Underlined words and phrases are defined in the glossary.

**OBJECTIVE 2.1****CONSERVATION OF MASS, ENERGY AND CHARGE** (Grades 5-8 and Grades 9-12)

*Students understand that at the macro (human) and atomic scale, mass and energy are conserved separately, within measurement errors, for all types of interactions and defined systems (open or closed). Charge is always conserved at all scales.*

*Clarification.* The physics standards use the conservation principle (sometimes called the continuity principle) as a central idea to organize and understand the interactions between objects and systems. For students in grades 5 - 8, the conservation of mass principle is addressed. For students in grades 9 - 12, both the conservation of charge and conservation of energy (macro scale) are addressed. The general principle of the conservation of mass–energy is introduced in Objective.2.3.

**Elementary Foundations**

By the end of grade 4, students know that:

1. No matter how parts of an object are assembled, the mass of the whole object is always the same as the sum of the parts; and when an object is broken into parts, the parts have the same total mass as the original object. [BSL 4D/E2\*]
2. Objects and substances may move from place to place, but they never appear out of nowhere and never just disappear. [BSL 4D/E8\*\*] It is helpful to keep track of where objects and substances come from and where they go. [BSL 11C/P2]
3. The number of objects in a group can stay the same even as some enter or leave, as long as each one that leaves is replaced by another one that is entering. [BSL 11C/E5\*\*]
4. Water can be a liquid or a solid and can go back and forth from one form to the other. If water is turned into ice and then the ice is allowed to melt, the amount of water is the same as it was before freezing.

**Grades 5 - 8**

*Clarification.* See Instructional Guidance for Standard 2 (page 89) for a clarification of the conservation principle and how the principle can be introduced in the early middle-school grades.

**RELATED OBJECTIVE:** Heating and Cooling Interactions and Energy (4.5)

**BOUNDARY.**<sup>†</sup> *Quantities students measure include, but are not limited to, the number of identical objects, length, perimeter, surface area, mass, volume, and density. The mass changes that students investigate should include both open and closed systems and a wide range of different types of interactions.*

**ESSENTIAL KNOWLEDGE\***

Students reason with and apply the following concepts in the learning outcomes:

- M.2.1.1** Scientists find it useful to compare a new idea about a system, process, or event with something that is familiar. The thing that is familiar is called an analogue model of the system, process, or event. [Same as in Objective 1.3]
- M.2.1.2** A quantity is “conserved” when the total change of the quantity within a defined system and time interval is equal to the total transfer of the quantity into or out of the system during the defined time interval.
- $$\text{total quantity change within system} = \text{total quantity transferred into or out of system}$$

<sup>†</sup> For further background and instructional guidance for each objective, including restrictions in the scope of the content for the learning outcomes, see Instructional Guidance for Standard 2, page 89.

\* For further clarification of the essential knowledge statements and learning outcomes for each objective, see the objective *Table of Common Student Conceptual Difficulties* in Instructional Guidance for Standard 2.

## ESSENTIAL KNOWLEDGE (5-8), continued

- a. A change in a quantity in a defined system is the value of the quantity before the event (Start Quantity) subtracted from the value of the quantity after an event (End Quantity):
- $$\text{change of quantity within system} = \text{End Quantity} - \text{Start Quantity}.$$
- b. The total transfer of a quantity into or out of a defined system is the value of the quantity transferred out of the system (Quantity Out) subtracted from the value of the quantity transferred into the system (Quantity In):

$$\text{total transfer of quantity} = \text{Quantity In} - \text{Quantity Out}.$$

**M.2.1.3** A system may stay the same because nothing is influencing it or the influences on it are balanced. [BSL 11C/M2]

**M.2.1.4** Most quantities, like surface area, perimeter, volume and density are not conserved for all types of interactions. Mass is **always** conserved, within measurement errors, for all interactions,<sup>1</sup> and for both closed and open systems.

$$\text{End Mass} - \text{Start Mass} = \text{Mass In} - \text{Mass Out}^2$$

$$\text{Start Mass} = \text{End Mass} + \text{Mass Out} - \text{Mass In}$$

$$\text{End Mass} = \text{Start Mass} + \text{Mass In} - \text{Mass Out}$$

**M.2.1.5** When energy is transferred into or out of a system without a transfer of materials, there is no change in mass of the system within measurement errors.

**M.2.1.6** The small-particle model of physical and chemical interactions is consistent with the conservation of mass principle. According to this model, during physical interactions atoms and molecules are rearranged, but the atoms do not change. During chemical reactions, the number and kinds of atoms in the reactants are the same as the number and kinds of atoms in the products – the atoms do not change.

## LEARNING OUTCOMES

Ways in which students engage with and apply the essential knowledge in order to understand the objective:

- Analyze and solve different word problems involving the conservation of identical objects by drawing a picture of the situation, writing a mathematical sentence for the conservation principle, and solving for the unknown quantity.
- Give real world examples of systems when mass is transferred into or out of the defined system, and when the rate of mass transfer into the system is the same as the rate of mass transfer out of the system (dynamic equilibrium).
- Investigate changes within a system and transfers into and/or out of the system for different quantities (e.g., mass, volume, surface area, density), for different physical interactions and chemical interactions, and different defined systems and time intervals. (a) Gather and record data on the quantity before and after a physical or chemical interaction, and the amount of the quantity transferred into and/o out of a system during the interaction. (b) Make a claim about whether the quantity is conserved or not conserved. Justification is based on the evidence and the conservation principle.
- Construct analogue models of the conservation of quantities from everyday life. Explain how the model is the same and different from the conservation of mass principle.
- Give examples of evidence supporting the conclusion that surface area, volume, and density are sometimes conserved and sometimes not conserved, while mass is conserved in all of the examples.
- Give examples of evidence supporting the conclusion that the transfer of energy into or out of an object/system (without a transfer of materials) does not change the mass of the system within the measurement errors.

<sup>1</sup> Nuclear and other subatomic interactions are excluded.

<sup>2</sup> Research indicates that different middle-school students tend to prefer one or two of three ways of representing a mathematical sentence for conservation. At this level, it is not important which way students prefer to reason with the conservation of mass principle.

## LEARNING OUTCOMES (5-8), continued

- Predict whether the mass of a defined system will decrease, stay the same, or increase for different physical and chemical interactions, and justify using the conservation of mass principle.
- Calculate the end mass of a defined system after different physical and chemical interactions, and justify by using the conservation of mass principle.

## Grades 9 - 12

*Clarification.* In these standards, the approach to energy and energy conservation is the same as in the new AP Physics B courses: there is only *one* conservation of energy equation and all other energy equations are special cases (e.g., conservation of mechanical energy, the first law of thermodynamics).<sup>3</sup>

**RELATED OBJECTIVES:** Interactions and Models of the Nucleus (1.3); Contact Interactions and Energy (4.1); Electric Current Interactions and Energy (4.2); Mechanical Wave Interactions and Energy (4.3); Radiant Energy Interactions (4.4); Heating and Cooling Interactions and Energy (4.5); and Potential Energy and Fields (5.2).

**BOUNDARY.<sup>†</sup> This is not a stand-alone objective.** The specific *methods of energy storage* and *methods of energy transfer* needed to apply the conservation of energy principle are defined in the five objectives of Standard 4 and in Objective 5.1.

## ESSENTIAL KNOWLEDGE

Students reason with and apply the following concepts in the learning outcomes: [SSCS, page 152]

- H.2.1.1** For all types of interactions (except nuclear and other subatomic particle interactions) and for all systems (open and closed), energy is always conserved within measurement errors. The mathematical form of the conservation of energy principle is the same as the conservation of mass principle: total energy change within system ( $\Delta E_{\text{system}}$ ) is equal to the total energy transfer into or out of system ( $E_{\text{in}} - E_{\text{out}}$ ):

$$\Delta E_{\text{system}} = E_{\text{in}} - E_{\text{out}}$$

where ( $\Delta E_{\text{system}}$ ) is the change in one or more methods of energy storage within a system, and  $E_{\text{in}}$  and  $E_{\text{out}}$  are one or more methods of energy transfer into or out of a system.

- H.2.1.2** The energy terms in the conservation of energy principle depend on the defined system and defined time interval. For any event or process, the terms in the conservation of energy equation will be different for different defined systems and time intervals.
- H.2.1.3** At the macro (human) scale, mass and energy are always conserved separately within measurement errors.
- H.2.1.4** Many events and processes involve multiple interactions occurring simultaneously and/or chains of interactions. When the details of the multiple transfers of energy are unknown or not of interest in a problem, the term “transformation” can be used (i.e., the initial form of energy is “transformed” into the final form of energy within the defined closed system). For radiant energy transfers into or out of a system, this description is often extended to include the transformation of radiant energy (electromagnetic waves or photons) into the final form(s) of energy within the system (e.g., chemical energy or thermal energy).
- H.2.1.5** Charge is always conserved for all types of interactions (including interactions of subatomic particles). The total change of charge within a system ( $\Delta q_{\text{system}}$ ) is equal to the total charge transferred into or out of the system ( $q_{\text{in}} - q_{\text{out}}$ ). This can be mathematically represented by:

$$\Delta q_{\text{system}} = q_{\text{in}} - q_{\text{out}}$$

- H.2.1.6** The conservation of charge, mass, and energy principles are examples of fundamental principles of science because they cannot be derived from other theories—all scientific theories must be consistent with these principles.

<sup>3</sup> A similar approach is described in a series of four articles in *The Physics Teacher* by John Jewett Jr. (2008a; 2008b; 2008c; 2008d).

## LEARNING OUTCOMES

Ways in which students engage with and apply the essential knowledge in order to understand the objective:

- Construct analogue models of the conservation of energy principle. Explain how each model is the same and different from the conservation of energy equation. Choose and justify which model (if any) is best for the purpose of making sense of (understanding) the conservation of energy equation.
- Analyze different problems involving multiple interactions (e.g., contact, electric circuit, mechanical wave, radiant energy, thermal, and/or gravitational interactions):
  - ◆ Select a system and time interval to solve the problem. Identify the interactions of the defined system with other systems. Identification is based on the defining characteristics of interactions and on information from the problem.
  - ◆ Determine and represent, with an energy diagram, the type and direction of energy transfers across the system boundary, as well as energy changes within the system.
  - ◆ Make claims about which terms in the conservation of energy equation are applicable, are zero or not applicable, or are too small to be measurable. Justify the claims based on knowledge of methods of energy storage and methods of energy transfer.
  - ◆ Write the conservation of energy equation for the problem.
  - ◆ Predict what would happen to a given energy term (increase, stay the same, decrease) in the conservation of energy equation under different conditions for the problem. Justification is based on the terms in the conservation of energy equation.
- Describe, using energy diagrams, the energy changes within a system and the transfer of energy into and out of a system, for different defined systems or time intervals of the same event. [SSCS, page 152]
- Explain why an energy description of an event for a given system can differ for different time intervals, and why an energy description of an event for a given time interval can differ for different systems of interest. [SSCS, page 152]
- Describe the same event in terms of energy transfers and energy transformations. Description is based on an energy diagram and the conservation of energy principle. [SSCS, page 152]
- Give examples of problem situations in which the conservation of charge must be used or assumed to solve the problem. (See Objective 3.5)
- Explain why the conservation of mass, charge, and energy are fundamental principles of science.

## OBJECTIVE 2.2

### CONSERVATION OF LINEAR MOMENTUM (Grades 9 - 12)

*Students understand that linear momentum is conserved at all size and time scales, and for all types of interactions and defined systems (open or closed).*

*Clarification.* Conservation of linear momentum is a fundamental principle of physics. This objective, which is limited to one dimension, provides a strong foundation for extending the content and skills to two- and three-dimensional linear momentum and angular momentum in an introductory college physics course. The objective can be introduced prior to, or after the introduction of Newton's laws (see Objective.3.2).

**RELATED OBJECTIVE:** Forces and Changing Motion (3.2)

**BOUNDARY.**<sup>†</sup> Problems are limited to motion in one dimension. A full discussion of collisions also requires conservation of energy, but collisions can be approached from the point of view of conservation of momentum, and energy can be discussed at a later time.

## ESSENTIAL KNOWLEDGE

Students reason with and apply the following concepts in the learning outcomes: [SSCS, page 154]

**H.2.2.1** All moving objects can be described by a quantity of motion called linear momentum. Momentum ( $p$ ) for objects with mass is a vector quantity that depends on the mass of the object (increasing with increasing mass), the velocity of the object (increasing with increasing velocity), and is in the direction the object is moving ( $\vec{p} = m\vec{v}$ ). There is no standard unit of momentum; the units are those of the product of mass and velocity, kg·m/sec.

**H.2.2.2** The conservation of linear momentum states that the total momentum change within a system is equal to the total momentum transfer into or out of the system. This can be mathematically represented by:

$$\Delta\vec{p}_{\text{system}} = \vec{p}_{\text{in}} - \vec{p}_{\text{out}}$$

The conservation of linear momentum is a fundamental principle of science because it cannot be derived from other theories. -- all scientific theories must be consistent with this principle.

**H.2.2.3** Linear momentum is always conserved for all types of interactions at all scales, and for both closed and open systems. For any system impulse — the total momentum transfer into or out of the system — is equal to the change in momentum for the system. This transfer is the result of interaction(s) with other systems outside the system boundary and can be mathematically represented by:

$$\Delta\vec{p}_{\text{system}} = \vec{p}_f - \vec{p}_i = \vec{F}_{\text{ave}}\Delta t,$$

where  $\vec{F}_{\text{ave}}$  is the vector sum of the *external forces* (net external force).

**H.2.2.4** Any combination of force and time could be used to produce the transfer of linear momentum (impulse) necessary for a given change of momentum of an object. The smaller the force, the longer the time interval over which the force acts; the larger the force, the shorter the time interval. Consequently, impulse is an important consideration in a number of real-world applications.

**H.2.2.5** The linear momentum of the system is constant in a system where the interactions across the system boundary may be neglected because they are insignificant compared to the interactions within the system, or because the time interval is very short.

**H.2.2.6** Newton's second and third laws of motion are a direct result of the conservation of linear momentum principle applied to cases of constant mass:

**[BOUNDARY: For inertial frames of reference, Newton's first law of motion is a special case of Newton's second law of motion. The distinction between gravitational and inertial mass is not necessary for preparing students for college success.]**

- a. The sum of external forces (net external force) acting on an object causes the object's momentum to change. The average force multiplied by the time interval is equal to the momentum change ( $m\Delta v$ ).

$$\Sigma\vec{F}_{\text{external}} = m(\Delta\vec{v} / \Delta t) = m\vec{a}$$

If there are no external forces acting on an object, the object's linear momentum (and therefore its motion) cannot change.

- b. Interaction forces between two objects cannot change the total momentum of the objects, since these forces would exist even if the system were isolated. Consequently, when two objects interact, the force on one object is equal in magnitude but opposite in direction to the force on the second object. This is the origin of Newton's third law.

**H.2.1.7** The conservation linear momentum is an example of a fundamental principle of science because it cannot be derived from other theories—all scientific theories must be consistent with this principle.

## LEARNING OUTCOMES

Ways in which students engage with and apply the essential knowledge in order to understand the objective: [SSCS, page 153]



## LEARNING OUTCOMES (9-12), continued

- **Investigate** the conservation of linear (one-dimensional) momentum for different **problem** situations involving open and closed systems and for different types of interactions (e.g., an automobile collision, a bat hitting a baseball, an object falling to the ground from rest).
  - ◆ Select a **system of interest** and time interval.
  - ◆ Predict the transfer of momentum into or out of a defined system during the interaction. Justification is based on the problem situation and the conservation of momentum principle.
  - ◆ Determine and justify the observations or data needed to test the prediction.
  - ◆ When appropriate, record and organize data, including estimates of measurement errors.
  - ◆ .When appropriate, analyze the data for outliers, and represent the data on a **momentum diagram**.
  - ◆ Make **claims** about the transfer of momentum into or out of a system. Claims are based on gathered data that can be used as evidence and the conservation of momentum principle.
- Predict qualitatively the change in direction of motion of two interacting objects. Justification is based on the initial conditions and on the relationship between the momenta of the two objects in a closed system.
- **Explain** when the external friction interaction may be ignored when using the conservation of linear momentum principle.
- Explain, using the conservation of linear momentum principle, how a process or design achieves a desired effect (e.g., reducing damage or injury, maximizing a force).
- Design or adapt a process to achieve a desired effect of increasing or decreasing the force applied to an object by using the conservation of linear momentum principle.
- Investigate **qualitatively** and make a claim about the changes in kinetic energy and linear momentum for a defined system of two objects in different problems involving inelastic collisions. Identify possible methods of energy transfer or transformation within the system to account for the “lost” kinetic energy, and construct energy and momentum diagrams. Justification is based on the conservation of energy and on the conservation of linear momentum. Explain where this energy has gone, and justify the explanation by using the conservation of energy principle and conservation of linear momentum principle.
 

*[BOUNDARY: Students are not expected to use the coefficient of restitution.]*
- Explain and justify how the conservation of linear momentum can be used in the investigation of traffic accidents to determine, based on measurements of the final motions, the initial motions of the objects.
- Calculate, using the conservation of linear momentum principle, the final velocity in a two-object system for different problems involving **totally inelastic collisions**.
- Predict algebraically the average force, initial or final velocity, mass, or time interval in **multistep** word problems. Justification is based on the conservation of linear momentum principle.
- Predict algebraically the average force, the initial or final velocity, masses or time interval in different multistep word problems in which external forces can be neglected and the approximation that no energy is dissipated can be made. Justify the prediction by constructing momentum diagrams and by using the conservation of linear momentum principle.
- Predicts algebraically the relative size of the accelerations of two interacting objects in word problems by drawing a momentum diagram and using the mathematical representation for the relationship between the momenta of the two objects in a closed system.
- Explain why the conservation of linear momentum is a fundamental principle of science. Justification should include the example of Newton’s laws derived from the conservation of linear momentum.

**OBJECTIVE 2.3****NUCLEAR INTERACTIONS AND THE CONSERVATION OF MASS-ENERGY (Grades 9 - 12)**

*Students understand that nuclear interactions result in product particle(s) with less mass than the original particle(s); the missing mass appears as an energy transfer out the system. Mass-energy is conserved at all size and time scales, for all types of interactions, and for all defined systems (open or closed).*

**Grades 9 - 12**

**Clarification.** In grades 5 - 8, students are introduced to the small-particle model of matter, chemical interactions and the periodic table. In grades 9 - 12, students extend this knowledge to include atomic structure (i.e., protons, neutrons and electrons in Objective 1.3) and nuclear interactions, which serve as an introduction to the conservation of mass-energy.

**RELATED OBJECTIVE:**  
Interactions and Atomic  
and Subatomic Models  
(1.3)

**BOUNDARY.<sup>†</sup>** Nuclear interactions are limited to radioactive decay, fusion and fission – other interactions involving protons or neutrons are excluded.

**ESSENTIAL KNOWLEDGE**

Students reason with and apply the following concepts in the learning outcomes: [SSCS, 155-156]

- H.2.3.1** The nuclear interaction between protons and neutrons is a non-electrical, attractive interaction-at-a-distance that binds them to form a stable nucleus. The nuclear force is much stronger than the electrical repulsive force between the protons for particle distances less than  $10^{-15}$  meters, but it becomes very, very weak for larger distances. Consequently, neutrons have little effect on how an atom interacts with other atoms, yet the number of neutrons does affect the mass and stability of the nucleus.
- H.2.3.2** Atoms with the same number of protons and a different number of neutrons are called isotopes. Most elements have more than one stable isotope. When an atom has an unstable nucleus, the unstable nucleus emits very fast-moving particles (e.g., alpha, beta, or positron). This process, called radioactive decay, results in nuclei of a different element being formed from the old one. Sometimes the emission of radiant energy (e.g., gamma rays) is part of this process. Atoms with an unstable nucleus are often called radioisotopes.
- H.2.3.3** Radioisotopes have several medical applications. The particles and radiant energy emitted as a result of the unstable nucleus have high energy and can be detected. These characteristics allow radioisotopes to be used as tracers of biological processes and to kill biological materials (e.g., cancer cells).
- H.2.3.4** Half-life is a measure of the rate of radioactive decay, or the amount of time it takes for half of a radioactive sample to decay to its products. For any radioisotope, the half-life is constant and unique and can be used to determine the age of the material.
- H.2.3.5** When two smaller nuclei combine to produce one larger nucleus, the interaction is called nuclear fusion. The process of fusion is the source of energy for stars. Elements heavier than hydrogen continue to be created as a result of fusion reactions in the centers of stars. In the fusion process, the mass of the product is less than the mass of the reactants. The missing mass appears as energy. These energy changes are much greater than those that accompany chemical reactions.
- H.2.3.6** When a large nucleus splits to produce two smaller nuclei, the interaction is called nuclear fission. In many fission reactions, energetic neutrons are also released, which can be absorbed by nearby nuclei, causing them to undergo fission. In the fission process, the mass of the product is less than the mass of the original nucleus. The missing mass appears as energy. These energy changes are much greater than those that accompany chemical reactions.
- H.2.3.7** As predicted by Albert Einstein in his special theory of relativity, during nuclear interactions, the transfer of energy out of a system is directly proportional to the change in mass of the system. The mass-energy equivalence principle is  $\Delta E = \Delta mc^2$ , where  $c$  is the speed of light in a vacuum. A very small change of mass within the system results in a large amount of energy transferred out of the system.

**H.2.3.8** A more general conservation principle is a combination of the conservation of mass principle and conservation of energy principle, including the mass-energy equivalence principle. Mass–energy (ME) is always conserved for all types of interactions at all scales.

$$\Delta ME_{\text{system}} = ME_{\text{in}} - ME_{\text{out}}, \text{ where ME is mass or energy.}$$

**H.2.3.9** Mass changes occur in *all* interactions. At the macro (human) scale, the mass changes are too small to be measurable, but they can be calculated.

**H.2.3.10** The conservation principles of mass-energy, linear momentum, and charge cannot be derived from other theories. They are considered to be *fundamental* principles of science and all other theories must be consistent with these fundamental principles.

## LEARNING OUTCOMES

Ways in which students engage with and apply the essential knowledge in order to understand the objective: [SSCS, page 155]

- Explain why the nuclear interaction among the protons and neutrons in the nucleus of an atom does not play a role in everyday phenomena. Justify the explanation by using knowledge of electrical and nuclear forces.
- Compare and contrast alpha and beta radioactive decay, in terms of what happens to the nuclei. Contrast includes visual representations of the two processes.
- Compare and contrast nuclear fusion with nuclear fission, in terms of what happens to the nuclei. Contrast includes visual representations of the two processes.
- Predict the new element that is formed during the radioactive decay (alpha decay or beta decay) of a given isotope. Justify the prediction by using the periodic table and knowledge of radioactive decay.
- Explain why it is possible to get more energy out of fission and fusion reactions than out of chemical reactions involving the same amount of material. Justification is based on knowledge of mass–energy equivalence.
- Calculate the energy required to fuse two atoms in a fusion reaction and the energy released in a fission reaction, using the mass–energy equivalence principle in the conservation of energy equation and knowledge of fusion and fission reactions. Calculations are based on the atomic masses of the product particle(s) and the masses of the original particle(s) that interacted to produce them.
- Explain and justify why it can be appropriate to solve some problems by using the conservation of mass principle or the conservation of energy principle, rather than the conservation of mass–energy principle.
- Explain why Newton’s laws of motion and Newton’s law of gravitation are not considered to be fundamental principles of science.



## STANDARD 3

### NEWTON'S LAWS OF MOTION

#### **Objective 3.1: Constant and Changing Linear Motion** (Grades 5-8 and 9-12)

*Students understand that linear motion is characterized by speed, velocity, and acceleration, and that velocity and acceleration are vectors.*

#### **Objective 3.2: Forces and Changes in Motion** (Grades 5-8 and 9-12)

*Students understand that interactions can be described in terms of forces. The acceleration of an object is proportional to the vector sum of all the forces (net force) on the object and inversely proportional to the object's mass ( $\vec{a} = \Sigma \vec{F} / m$ ). When two interacting objects push or pull on each other, the force on one object is equal in magnitude but opposite in direction to the force on the other object.*

#### **Objective 3.3: Contact Interactions and Forces** (Grades 5-8 and 9-12)

*Students understand that contact interactions occur when two objects in contact push or pull on each other, which can cause a change in the motion of the objects. Some types of contact interactions have force laws that are empirical approximations; some have no force laws.*

#### **Objective 3.4: Gravitational Interactions and Forces** (Grades 5-8 and 9-12)

*Students understand that gravity is an attractive interaction between any two objects with mass, which can cause a change in the motion of the objects. Gravitational interactions are governed by a force law.*

#### **Objective 3.5: Magnetic and Electrical Interactions and Forces** (Grades 5-8 and 9-12)

*Students understand that both magnetic interactions and electrical interactions occur between mutually attracting or repelling objects, which can cause a change in the motion of the objects. Electrical interactions apply to point charges, and are governed by a force law.*

*Interactions of an object with other objects can be described, explained, and predicted using the concept of forces, which can cause a change in motion of one or both interacting objects. Different types of interactions are identified by their defining characteristics. At the macro (human) scale, interactions are governed by Newton's second and third laws of motion.*

Students understand that scientists believe that that the things and events we observe occur in consistent patterns that are comprehensible through careful, systematic investigations. To search for consistent patterns in the multitude of interactions and changes we observe, scientists classified different types of interactions, for example contact interactions, gravitational interactions, magnetic interactions, and electrical (electrostatic) interactions. The defining characteristics of an interaction are: (1) the conditions necessary for the interaction to occur (e.g., two objects must be touching, one object must be charged, one object must be a solid and the other a fluid, and so on); (2) the evidence of the interaction – the observed changes; and (3) the variables that influence the strength of the interaction.

One way scientists describe different types of interactions is with the idea that during some interactions, objects exert forces on each other which can cause a *change in motion* of one or both objects (the evidence of an interaction). Changes in the linear motion of an object are characterized by speed, velocity, and acceleration, and velocity and acceleration are vectors. Many of the “formulas” in physics are the third defining characteristic of different types of interactions – empirical approximations (e.g.,  $f_k = \mu_k N$  for friction) or force laws (e.g., Newton's Universal Law of Gravitation, Coulomb's Law) of the variables that determine the strength of the forces between two interacting objects. When an object is simultaneously interacting with more than one other object, then the acceleration of the object is proportional to the vector sum of the forces acting on the object ( $\Sigma \vec{F} = m \vec{a}$ ), Newton's second law of motion). When interacting objects push or pull on each other, the force on one object is equal in magnitude but opposite in direction to the force on the other object (Newton's third law of motion).

**CLARIFICATION.** The objectives for this standard are limited to linear or uniform circular motion and forces in order to meet the college-ready goal of depth of understanding, yet leave no important content gaps. The objectives in this standard provide a strong foundation to extend the content and skills to two- and three dimensional motion and forces in college introductory physics courses.

**OBJECTIVE 3.1****CONSTANT AND CHANGING LINEAR MOTION** (Grades 5-8 and Grades 9-12)

*Students understand that linear motion is characterized by speed, velocity, and acceleration, and that velocity and acceleration are vectors.*

**Elementary Foundations**

By the end of grade 4, students know that:

1. An object's position can be described by locating the object relative to other objects or a background. The position of an object from one observer's view may be different from that reported from a different observer's view.
2. Two clock readings, a start clock reading and an end clock reading, are required to determine an amount of time or time interval. Common units of time intervals are seconds, minutes, hours, days, and years. A time interval does not depend on the choice of the start clock reading.
3. Often the best way to tell which kinds of change are happening is to make a table or graph of measurements. [BSL 11C/E2b]
4. An object is in motion when its position changes over time. Tracing and measuring its position over time can describe an object's motion. [NSES K-4B2.1]
5. The (constant) speed of an object tells us the distance the object moves in each unit time interval. The speed of things differs greatly. Some things are so slow that their journey takes a long time; others move too fast for people to even see them. [BSL 4F/E2]

**Grades 5 - 8**

**Clarification.** Students in grades 5-8 begin to develop fluency with different representations for describing, explaining and predicting patterns of straight-line motion of objects: verbal and/or written descriptions, graphs of distance versus time, motion diagrams,<sup>‡</sup> and mathematical representations of constant and average speed.

**RELATED OBJECTIVES:** Interactions, Models, and Scales (1.1); College Board *Standards for College Success™: Mathematics and Statistics* MI.1.4, MI.2, MI.6, MII.1.2, MII.1.4, and MII.6.

**BOUNDARY.<sup>†</sup>** Motion is limited to objects moving in straight lines horizontally, up an incline, or down an incline. Excluded are the terms "velocity" and "acceleration," which are introduced at the Grades 9-12 level.

**ESSENTIAL KNOWLEDGE\***

Students reason with and apply the following concepts in the learning outcomes:

- M.3.1.1** The basic patterns of the straight-line motion of objects are: no motion, moving with a constant speed, speeding up, slowing down and changing (reversing) direction of motion. Sometimes an object's motion can be described as a repetition and/or combination of the basic patterns of motion. [SSCS, page 90]
- M.3.1.2** An object that travels the same distance in each successive unit of time has a constant speed. The constant speed of an object can be represented by and calculated from the mathematical representation (speed = distance traveled/time interval), data tables, a motion diagram and the slope of the linear distance versus time graph. [SSCS, page 90]

<sup>‡</sup> Underlined words and phrases are defined in the glossary.

<sup>†</sup> For further background and instructional guidance, including restrictions in the scope of the content for the learning outcomes in each objective, see Instructional Guidance for Standard 3, page 99.

\* For further clarification of the learning outcomes and essential knowledge statements for each objective, see the objective *Table of Common Student Conceptual Difficulties* in Instructional Guidance for Standard 3.

- M.3.1.3** When the distance an object travels increases with each successive unit of time, it is speeding up; when the distance an object travels decreases with each successive unit of time, it is slowing down. [SSCS, page 90]
- M.3.1.4** The relationship between distance and time is nonlinear when an object's speed is changing and when it is moving in a series with different constant speeds. [SSCS, page 90]
- The constant speed an object would travel to move the same total distance in the same total time interval is the *average speed*.
  - Average speed can be represented and calculated from the mathematical representation (average speed = total distance traveled/total time interval), data tables, and the nonlinear distance versus time graph. [SSCS, page 90]
  - For objects traveling to a final destination in a series of different constant speeds, the average speed is not the same as the average of the constant speeds. [SSCS, page 90]

## LEARNING OUTCOMES

Ways in which students engage with and apply the essential knowledge in order to understand the objective:

- Investigate the patterns of motion of objects in different experimental situations: [SSCS, page 89]
  - ◆ Ask and refine a scientific question about the basic pattern of motion of the object.
  - ◆ Determine and justify the data needed to answer the scientific question about the pattern of motion of the object.
  - ◆ Follow a protocol to collect, record and organize data about the position of the moving object at different times (clock readings). Data include estimates of measurement errors.
  - ◆ Analyze the data for outliers, and represent the motion of the object on a graph showing distance versus time, and with a motion diagram.
  - ◆ Determine whether the data can be used as evidence to support a claim about the pattern of motion.
  - ◆ Make a claim about the pattern of motion of the object. Justification should include the evidence and knowledge of the different patterns of motion of objects.
- Translate among different representations (e.g., verbal descriptions, motion diagrams, data tables, distance versus time graphs) of the patterns of motion of objects. [SSCS, page 89]
- Explain what is changing and what is not changing for an object moving at a constant speed. Justify the explanation by constructing sketches of distance versus time graphs. [SSCS, page 89]
- Predict numerically the distance traveled, or the time interval for different situations involving motion with constant speed. Justify the prediction by using the mathematical representation for constant speed. [SSCS, page 89]
- Analyze different problems to determine whether the average speed of an object has been calculated correctly or incorrectly. If correct, interpret the meaning of the average speed. If incorrect, describe how to calculate the average speed correctly.
- Calculate, using the mathematical representation, the average speed of an object for problems in which an object is speeding up, slowing down or traveling in a series of constant speeds. Interpret the meaning of the average speed.
- Explain the differences between the average speed and constant speed for objects undergoing a change in motion. Justification is based on observations, sketches of motion diagrams and of distance versus time graphs, and knowledge of rates of change and changes in motion. [SSCS, page 89]
- Recognize when the evidence is convincing or not convincing to support claims about the pattern of motion of an object, using the criteria: (a) appropriate match of the evidence to the question; (b) adequate precision and accuracy (i.e., adequate precision of measuring instruments, adequate care taken in measurement procedures, and sufficient data was collected – sample size was large); (c) adequate data analysis and representation procedures were used; and (d) the investigation was replicated (by other groups or classes).

## LEARNING OUTCOMES (5-8), continued

- Recognize when the quality of claims about the pattern of motion of an object are adequate or inadequate (poor) for situations in which the evidence is convincing, using the criteria: (a) the claim is based on the evidence, not opinion; (b) all the evidence is used, not just selected portions of the evidence; (c) the claim is based on correct scientific ideas of the different patterns of motion of objects; and (d) the justification links the evidence and scientific ideas about patterns of motion to the claim in a logical manner.

## Grades 9 - 12

**Clarification.** In grades 9-12, students continue to develop fluency with different representations used to solve problems involving the straight-line motion of objects, including an introduction to simple, one-dimensional vector representations of displacement, velocity, instantaneous velocity and constant acceleration. The change in these quantities is determined by vector subtraction.

**RELATED OBJECTIVES:** Conservation of Linear Momentum (2.3); College Board Standards for College Success™: Mathematics and Statistics AI.1, AI.2, AI.3.1, and AI.3.1

**BOUNDARY.†** Motion is limited to objects moving in straight lines horizontally, up an incline, and/or down an incline. Since motion is linear, the sign determines the direction for all vector quantities.

### ESSENTIAL KNOWLEDGE

Students reason with and apply the following concepts in the learning outcomes:

- H.3.1.1** The displacement, or change in position, of an object is a vector quantity that can be calculated by subtracting the initial position from the final position, where initial and final positions can have positive and negative values ( $\Delta x = x_f - x_i$ ). Displacement is not always equal to the distance traveled. [SSCS, page 143]
- H.3.1.2** An object that travels the same displacement in each successive unit time interval has constant velocity. Constant velocity is a vector quantity and can be represented by and calculated from a position versus time graph, a motion diagram or the mathematical representation for average velocity. The sign (+ or -) of the constant velocity indicates the direction of the velocity vector, which is the direction of motion. [SSCS, page 143]
- H.3.1.3** The constant velocity an object would travel to achieve the same change in position in the same time interval, even when the object's velocity is changing, is the average velocity for the time interval. Average velocity can be mathematically represented by  $v_{ave} = (x_f - x_i)/(t_f - t_i)$ . For straight-line motion, average velocity can be represented by and calculated from the mathematical representation, a curved position versus time graph and a motion diagram. [SSCS, page 143]
- H.3.1.4** The velocity of an object in straight-line motion changes continuously, from instant to instant while it is speeding up or slowing down and/or changing direction. The velocity of an object at any instant (clock reading) is called its *instantaneous velocity*. The object does not have this velocity over any time interval or travel any distance with this velocity. Instead, the instantaneous velocity is the constant velocity at which an object would continue to move if its motion stopped changing at that instant. An object with zero instantaneous velocity can be accelerating (e.g., motion up a ramp then back down the ramp). [SSCS, page 143]
- H.3.1.5** When the *change* in an object's instantaneous velocity is the same in each successive unit time interval, the object has constant acceleration. For straight-line motion, constant acceleration can be represented by and calculated from a linear instantaneous velocity versus time graph, a motion diagram and the mathematical representation [ $a = (v_f - v_i)/(t_f - t_i)$ ]. The sign (+ or -) of the constant acceleration indicates the direction of the change-of-velocity vector. A negative sign does not necessarily mean that the object is traveling in the negative direction or that it is slowing down. [SSCS, page 144]
- [BOUNDARY:** The term "deceleration" should be avoided because students tend to associate a negative sign of acceleration only with slowing down.]
- H.3.1.6** When the acceleration is not constant, the graph of instantaneous velocity versus time is curved. Average acceleration over any interval is the constant acceleration an object would have for the same total change in



velocity in the same time interval. Average acceleration can be calculated from the non-linear instantaneous velocity versus time graph.

**H.3.1.7** When the acceleration is constant, the magnitude of the average velocity during a time interval is one-half of the sum of the initial and final instantaneous velocities [ $v = (v_f + v_i)/2$ ]. [SSCS, page 144]

## LEARNING OUTCOMES

Ways in which students engage with and apply the essential knowledge in order to understand the objective:

- Represent and calculate the distance traveled by an object, as well as the displacement, the speed and the velocity of an object for different problems. Representations include data tables, distance versus time graphs, position versus time graphs, motion diagrams and their mathematical representations. Interpret the meaning of the sign (+ or -) of the displacement and velocity. [SSCS, page 142]

*[BOUNDARY: Problems should include situations in which the distance traveled is not the same as the displacement, and objects move from higher to lower positions.]*

- Investigate, and make a claim about the straight-line motion of an object in different laboratory situations. Representations include data tables, position versus time graphs, instantaneous velocity versus time graphs, motion diagrams, and their mathematical representations. When appropriate, calculate the constant velocity, average velocity or constant acceleration of the object. Interpret the meaning of the sign of the constant velocity, average velocity or constant acceleration. Interpret the meaning of the average velocity. [SSCS, page 143]
  - Explain what is “constant” when an object is moving with a constant velocity and how an object with a negative constant velocity is moving. Justify the explanation by constructing sketches of motion diagrams and using the shape of position and instantaneous velocity versus time graphs. [SSCS, page 143]
  - Explain what is “constant” when an object is moving with a constant acceleration, the two ways in which an object that has a positive constant acceleration can be moving<sup>1</sup>, and the two ways in which an object that has a negative constant acceleration can be moving<sup>2</sup>. Justify the explanations by constructing sketches of motion diagrams and using the shape of instantaneous velocity versus time graphs. [SSCS, page 143]
  - Compare and contrast the following: distance traveled and displacement; speed and velocity; constant velocity and instantaneous velocity; constant velocity and average velocity; and velocity and acceleration. [SSCS, page 143]
  - Translate between different representations of the motion of objects: verbal and/or written descriptions, motion diagrams, data tables, graphical representations (position versus time graphs and instantaneous velocity versus time graphs) and mathematical representations. [SSCS, page 143]
  - Predict algebraically a displacement, an initial or final time (clock reading), or a time interval for different problems involving objects that are moving with either a constant velocity or a constant acceleration. Justify the prediction by constructing a motion diagram and using mathematical representations. [SSCS, page 143]
  - Predict algebraically a displacement, an initial or final time (clock reading), or an initial or final instantaneous velocity in different problems. Justify the prediction by constructing motion diagrams and using the mathematical representations for constant velocity, constant acceleration, and/or the relationship between average velocity and initial and final instantaneous velocities for constant acceleration. [SSCS, page 143]
- [BOUNDARY: Students should not be given problems that require them to solve a quadratic equation.]*
- Evaluate the evidence for claims about the velocity or acceleration of objects in different experimental problems, using the criteria: (a) appropriate match of the evidence to the question or prediction; (b) adequate precision and accuracy (adequate precision of measuring instruments, careful measurement procedures were followed, enough data collected (sample size is large), a control sample of data is included when appropriate other

<sup>1</sup> Positive acceleration can be speeding up in the positive direction or slowing down in the negative direction.

<sup>2</sup> Negative acceleration can be slowing down in the positive direction or speeding up in the negative direction.

## LEARNING OUTCOMES (9-12), continued

conditions or variables were the same when the measurements were made, and no sampling bias); (c) correctness of data analysis and representation procedures (e.g., error bars on graphs for best estimate of slopes); and (d) the investigation was replicated (by other groups or classes).

**OBJECTIVE 3.2****FORCES AND CHANGES IN MOTION (Grades 5-8 and Grades 9-12)**

*Students understand that interactions can be described in terms of forces. The acceleration of an object is proportional to the vector sum of all the forces (net force) on the object and inversely proportional to the object's mass ( $\vec{a} = \Sigma \vec{F} / m$ ). When two interacting objects push or pull on each other, the force on one object is equal in magnitude but opposite in direction to the force on the other object.*

**Clarification.** **This objective is not a stand-alone objective** — it is linked to Objectives 3.3 (Contact Interactions and Forces), 3.4 (Gravitational Interactions and Forces) and 3.5 (Electrical Interactions and Forces), which provide the specific types of interaction forces needed to apply Newton's laws.

**BOUNDARY.** *Two-dimensional forces and motion are excluded. Motion is limited to inertial frames of reference, so Newton's first law is a special case of Newton's second law. Excluded is the distinction between gravitational and inertial mass.*

**Elementary Foundations**

By the end of grade 4, students know that:

1. The speed and direction of motion of objects can be changed by pushing or pulling. [BSL 4F/E1a]
2. The greater the force (push or pull) is, the greater the change in motion will be. The more massive an object is, the less effect a given force will have. [BSL 4F/E1bc]

**Grades 5 – 8**

**Clarification.** In grades 5–8, students begin to develop fluency with one-dimensional **force diagrams** and relate the vector sum of all the forces (net force) acting on an object to changes in the straight-line motion (speeding up, slowing down and/or changing direction) of the object.

**RELATED OBJECTIVES:** Interactions, Systems, and Scale (1.1); Conservation of Mass, Energy, and Charge (2.1); Objectives 3.1 and 3.3 – 3.5 for specific types of interactions.

**BOUNDARY.<sup>†</sup>** *Forces and motion are limited to horizontal, one dimension or uniform circular. The terms "net force" and "acceleration" are not introduced until grades 9-12 because of the conceptual difficulty middle-school students have understanding and using these terms. In addition, Newton's third law is not introduced until grades 9-12. This eliminates **problems** requiring the third law (e.g., objects at rest, a person who is walking or a moving car).*

**ESSENTIAL KNOWLEDGE**

Students reason with and apply the following concepts in the learning outcomes:

- M.3.2.1** One way that scientists describe, explain, and predict interactions is with the idea of forces. A force can be modeled as a push or pull applied on an object by the interacting object. Forces have both strength (magnitude) and a direction, and can be measured with calibrated spring scales. The common unit of force is the Newton (N).

**M.3.2.2** Newton's second law of motion includes the following ideas:

- A force applied on an object in the direction of its motion causes the object's speed to increase (the object speeds up).
- A force applied on an object in a direction opposite its motion causes the object's speed to decrease (the object slows down).
- A force can also change the direction of motion of an object.
- A force of constant magnitude acting at right angles to the direction of the object's motion causes the object to move in a circle at a constant speed. [See Objective 3.4]
- When multiple forces are acting on an object, the change in motion of the object is determined by the sum of the forces (Newton's second law), which can be found using vector addition. The sum of the forces is not a real force caused by an interacting object; it is the single force that could replace the original multiple forces and cause the same change in motion.
- When the sum of forces is zero (e.g., two forces on object have same magnitude but act in opposite directions), then there is no change of motion – the object stays still or continues to move with constant speed in the same direction.

**M.3.2.3** The forces acting on an object can be represented by arrows (vectors) drawn on an isolated picture of the object, called a force diagram. The direction of each arrow shows the direction of the push or pull. Forces are labeled: "(type of interaction) push or pull of (interacting object) on the (object of interest). For example: "drag push of the wind on the sails of the boat."

## LEARNING OUTCOMES

Ways in which students engage with and apply the essential knowledge in order to understand the objective:

- Investigate and make a claim about the relationship between a constant force on an object and the pattern of motion of the object. Justification is based on data that is evidence for the relationship.
- Give examples of how to change the motion of an object (i.e., change speed, change direction or move in a circle) in different situations, and explain each example. Justification is based on knowledge of interactions and forces.
- Analyze force diagrams to determine if they accurately represent different problem situations involving contact, magnetic, and/or electrical interactions. [SSCS, page 90]
- Analyze force diagrams of different real-world situations involving magnetic, electrical and/or contact interactions. Predict the object's motion (object speeds up, slows down, changes direction, moves in a circle, doesn't move, or continues to move at a constant speed in the same direction). Justify using Newton's second law. When appropriate, use vector addition to determine the size and direction of the sum of the forces, and interpret the meaning of the sum of the forces.

**[BOUNDARY: No more than three forces.]**

- Determine, given a force diagram and the initial motion of an object, the change in motion of the object, and explain why the change occurs. Justification is based on Newton's second law.
- Given real-world situations involving magnetic, electrical and/or contact forces and an identified object of interest. [SSCS, page 90]
  - ◆ Identify the objects involved in the interaction, and identify the pattern of motion for each object (i.e., no motion, moving with a constant speed, speeding up, slowing down or changing [reversing] direction of motion).
  - ◆ Make a claim about the types of interactions involved in the various situations. Justification is based on the defining characteristics of each type of interaction.
  - ◆ Represent the forces acting on the object of interest by drawing a force diagram.
  - ◆ Explain the observed motion of the object. Justification is based on Newton's second law.

## LEARNING OUTCOMES (5-8), continued

- ◆ When appropriate, use vector addition to find the sum of the forces. Interpret the meaning of the sum of the forces.

See Objectives 3.3, 3.4, and 3.5 for additional learning outcomes.

## Grades 9 - 12

**Clarification.** In grades 9–12, students continue to develop fluency with force diagrams in more complex situations, relate the linear acceleration of an object with the vector sum of all the forces (net force) on the object and with the mass of the object, and apply Newton’s third law.

**RELATED OBJECTIVES:**

Conservation of Linear Momentum (2.2); Objective 3.1, and 3.3 – 3.5 for specific types of interactions.

**BOUNDARY.†** Forces and motion are limited to horizontal or vertical one dimensional or uniform circular. Problem types are the same as for grades 5–8, but involve more complex situations, including situations involving linear motion in two parts (e.g., object accelerates and then moves with a constant velocity), situations involving the linear motion of two objects, and situations involving Newton’s third law (e.g., objects at rest, a person who is walking or a moving car).

## ESSENTIAL KNOWLEDGE

Students reason with and apply the following concepts in the learning outcomes: [SSCS, page 145]

**H.3.2.1** The force on a 1 kg mass that causes an acceleration of 1 m/s<sup>2</sup> is one Newton (N), where a Newton is defined as kg m/s<sup>2</sup>. Since many events consist of a sequence of interactions, the force diagram for an object/system of interest can be different for different time intervals.

**H.3.2.2** Newton’s second law of motion includes the following ideas:

- a. The linear acceleration of an object is directly proportional to the vector sum of all the forces acting on the object and inversely proportional to the object’s mass ( $\vec{a} = \Sigma \vec{F} / m$ ). The vector sum of all the forces (net force) is not a real force caused by an interaction with another object. The single force that could replace the original multiple forces and cause the same acceleration of the object is the vector sum of forces.
- b. A special case of Newton’s second law occurs when the vector sum of all the forces (net force) on an object is zero. In this case, there is no acceleration and the object either remains at rest or maintains a constant speed and a constant direction of motion.
- c. An object moves in a circle when the vector sum of all the forces (net force) is constant in magnitude, always directed at right angles to the direction of motion and always directed toward the same point in space, the center of the circle. The speed of the object does not change: the acceleration causes the continual change in the direction of the change-in-velocity vector.

**H.3.2.3** When two interacting objects push or pull on each other, the force on one object is equal in magnitude but opposite in direction to the force on the other object (Newton’s third law of motion for an interaction pair).

## LEARNING OUTCOMES

Ways in which students engage with and apply the essential knowledge in order to understand the objective: [SSCS, pages 144-145]

- Analyze force diagrams to determine if they accurately represent different situations involving multiple contact, gravitational and/or electrical interactions. When appropriate, determine the one-dimensional vector sum of all the forces (net force), and interpret the meaning of the vector sum of all the forces (net force).
- Analyze different problems involving at least two different types of interactions (contact, gravitational, magnetic and/or electrical) and an identified object of interest.
  - ◆ Identify the types of objects interacting with the object of interest, and observe the motion of each object.

## LEARNING OUTCOMES (9-12), continued

- ◆ Make a claim about the types of interactions. Justification is based on the evidence and the defining characteristics of the different types of interactions.
- ◆ Represent the forces acting on the object of interest by drawing a force diagram showing both the vertical and horizontal forces. When appropriate, use vector addition to determine the relative size and direction of the sum of all the forces (net force), and interpret the meaning of the net force.
- ◆ Explain the observed motion of the object of interest. Justification is based on Newton's second law.
- Evaluate explanations and predictions using the following criteria: (a) the explanation or prediction is complete (all relevant evidence and/or scientific ideas are included); (b) the explanation or prediction is based on evidence and correct physics ideas (not opinions); (c) the explanation or prediction is clear and concisely written; and (d) the justification links the evidence and scientific ideas to the claim in a logical manner.
- Identify the interaction (third-law) pair of any force in different problems. Compare the size and direction of the interaction pair of forces. Construct force diagrams that show all interaction (third-law) pairs.
- Predict algebraically a force, the linear acceleration, the initial or final velocity, or the initial or final time (clock readings) in different problems. Justify the prediction by constructing one-dimensional motion and force diagrams and by using the mathematical representations of average velocity and constant acceleration, the defining characteristics of different types of interaction forces, and Newton's second and third laws of motion.
- Investigate and explain why an object moving at a constant speed in a circle is accelerating. Justify the explanation by constructing a motion diagram and by using knowledge of acceleration and Newton's second law.

**[BOUNDARY:** *Students are only required to explore two-dimensional vector subtraction in this one case; they are not required to become proficient.*]

See Objectives 3.3, 3.4, and 3.5 for additional learning outcomes.

## OBJECTIVE 3.3

### CONTACT INTERACTION AND FORCES (Grades 5-8 and Grades 9-12)

*Students understand that contact interactions occur when two objects in contact push or pull on each other, which can cause a change in the motion of the objects. Some types of contact interactions have force laws that are empirical approximations; some have no force laws.*

**BOUNDARY.** *This objective is not a stand-alone objective – it is related to Objectives 4.2 (Constant and Changing Linear Motion) and Objective 4.3 (Interactions, Forces, and Changing Motion). The situations are limited to one dimension and to horizontal motion and forces.*

### Elementary Foundations

Same as in Objective 3.2 (Interactions, Forces, and Changes in Motion)

### Grades 5 - 8

**Clarification.** In grades 5–8, students are introduced to the qualitative defining characteristics of applied, elastic (e.g., spring), sliding (kinetic) friction, and drag interactions.

**RELATED OBJECTIVE:** Contact Interactions and Energy (4.1)

**BOUNDARY.<sup>†</sup>** *Interactions are limited to horizontal, one-dimension or circular motion, and those in which contact interactions predominate (i.e., other types of simultaneous interactions are negligible). Excluded are problem situations involving gravitational and static friction interactions, and situations requiring the application of Newton's third law (e.g., an object resting on a table or ground, person walking, an accelerating car).*

## ESSENTIAL KNOWLEDGE

Students reason with and apply the following concepts in the learning outcomes:

- M.3.3.1** Interactions can be classified by the following defining characteristics: (1) the conditions necessary for the interaction to occur (e.g., two objects must be touching, one object must be charged, one object must be moving, one object must be a solid and the other a fluid, etc.); the evidence of the interaction – the observed changes; and (3) the variables that influence the strength of the interaction (forces, energies, and/or fields).
- M.3.3.2** Contact interactions occur when a macro (human) scale object (e.g., rope, baseball, skateboard) pushes or pulls on another object during the time interval while they are touching. The evidence of the interaction is a change in motion of one or both of the interacting objects.
- M.3.3.3** During contact interactions, forces are not transferred to objects (unlike energy) — the interaction stops as soon as the objects stop touching. [SSCS, page 92]
- M.3.3.4** There are different types of contact interactions based on different defining characteristics.
- An applied interaction occurs between two objects that do not stretch, change shape, or break during the interaction. An applied force can be either a push or pull. [SSCS, page 92]
  - An elastic interaction occurs when two objects push or pull on each other and at least one solid object is stretched, compressed, or bent. A stretched spring or a rubber band pulls on an object attached to its end, and a compressed spring pushes. The magnitude of the force that an elastic object exerts on another object depends on the “stiffness” of the elastic object and on the distance that the elastic object is stretched, compressed, or bent.
  - A drag interaction occurs when a solid object is moving *through* a fluid (gas or liquid) and when a fluid is moving around an object (e.g., wind, a river flowing around a boulder). The drag force on an object is applied to the surface area facing the direction of motion of the object or fluid. The magnitude of the drag force on a solid object increases with the speed of the object or fluid and with the surface area of the object facing the direction of motion of the object or fluid.
  - A sliding (kinetic) friction interaction occurs when the surfaces of two solid objects slide past each other. The kinetic friction force on an object is applied to the sliding surface, and the direction of the force is opposite to the direction of the sliding.
  - For an object with wheels, a rolling friction interaction occurs between the parts of the wheel that rub together and the rest of the object. The rolling friction force is applied by the wheels on the axle-object part of the object, and the direction of the force is opposite to the direction of the rolling.

## LEARNING OUTCOMES

Ways in which students engage with and apply the essential knowledge in order to understand the objective:

- Given real-world situations involving a simple contact interaction between two objects: (a) Identify the objects involved in the contact interaction, and observe the changes in motion of each object. (b) Make a claim about the defining characteristics of each type of contact interaction. Represent the force on the object of interest by drawing a force diagram. [SSCS, pages 91-92]
- Compare and contrast applied, elastic, sliding (kinetic) friction, and drag interactions based on the defining characteristics of the interactions.
- Investigate the variables that could affect the magnitude of the elastic force and drag force on an object. (a) Ask and refine a scientific question about a variable that could affect the magnitude of the elastic or drag force. (b) Follow a structured protocol for observing the motion of the object for different values of the variable and for recording the observations on data tables. (c) Analyze and represent the data on graphs. (d) Make a claim, based on the evidence and Newton’s second law, about the relationship between the variable and the magnitude of the elastic force or drag force.<sup>3</sup>

<sup>3</sup> The variables that affect the magnitude of the kinetic friction force are investigated in grades 9-12.

## LEARNING OUTCOMES (5-8), continued

- Analyze real world situations involving contact interactions.
  - ◆ Identify the objects involved in the interaction, and identify the pattern of motion for each object (i.e., no motion, moving with a constant speed, speeding up, slowing down or changing [reversing] direction of motion, moving in a circle).
  - ◆ Make a claim about the types of contact interactions involved in the various situations. Justification is based on the defining characteristics of each type of interaction.
  - ◆ Represent the forces acting on the object of interest by drawing a force diagram.
  - ◆ Explain the observed motion of the object. Justification is based on Newton’s second law.
  - ◆ When appropriate, use vector addition to find the sum of the forces. Interpret the meaning of the sum of the forces.
- Predict what happens to the elastic force on an object (decreases, stays the same, increases) when the “stiffness” of the interacting elastic object changes or when the distance the elastic object is stretched or compressed changes. Justification is based on knowledge of the variables that affect the magnitude of elastic forces. [SSCS, page 92]
- Predict what happens to the drag force on an object (decreases, stays the same, increases) for different problems in which the speed of the object changes, or the surface area facing the direction of motion changes. Justification is based on knowledge of the variables that affect the magnitude of drag forces.
- Make a claim about whether a prediction is good or poor based on the criteria: (a) the prediction uses evidence and/or the correct science ideas; the prediction is complete (all important evidence and/or scientific ideas are used); and (c) it is not based on opinions.
- Identify all of the forces on an object in different real-world situations. Make a claim as to why, in some situations, the drag force of the air on a solid object can be ignored. Justification is based on the size and/or relative speed of the object as it moves through the air. [SSCS, page 92]

## Grades 9 - 12

*Clarification.* In grades 9–12, contact interactions are expanded to include the defining characteristics of additional types of interactions and the empirical force laws for the elastic, kinetic friction and static friction interactions. Students also explore simplifying assumptions for solving problems involving contact interactions.

**RELATED OBJECTIVES:** Interactions and Atomic and Subatomic Models (1.3); Interactions and Conservation of Mass, Energy, and Charge (2.1); Conservation of Linear Momentum (2.2); Contact Interactions and Energy (4.1)

**BOUNDARY.<sup>†</sup>** *The situations are limited to horizontal or vertical motion and forces in more complex problems than those that are covered in grades 5–8. Such complications as dimpled surfaces (e.g., golf balls, baseballs) are not considered.*

## ESSENTIAL KNOWLEDGE

Students reason with and apply the following concepts in the learning outcomes:

- H.3.3.1** The types of interactions of the object/system of interest with its surroundings and the force laws for each type of interaction must be identified in order to use Newton’s laws to explain and predict quantitatively the motion of an object or system. [SSCS, page 147]
- H.3.3.2** There are empirical force laws for some types of contact interactions. [SSCS, page 147]
- a. Elastic materials stretch or compress in proportion to the applied force. The mathematical model (Hooke’s Law) for the force that a linearly elastic object exerts on another object is  $F_{\text{elastic}} = k\Delta x$ , where  $\Delta x$  is the displacement of the object from its relaxed position. The direction of the elastic force is always toward the relaxed position of the elastic object. The constant of proportionality is the same for compression and extension, and depends on the “stiffness” of the elastic object.



- b. The force of kinetic friction always acts in the opposite direction of the relative velocity of the object with respect to the surface it is sliding over. The magnitude of the kinetic friction depends on the types of materials that make up the two surfaces sliding past each other and the magnitude of the compression (normal) force acting on the object. This can be mathematically represented by  $F_k = \mu_k N$ .
- c. When an external force is applied parallel to two surfaces that are in contact, a force opposes the external force and keeps the objects from moving relative to each other. This interaction is called *static* friction, which is mathematically represented by an inequality:  $F_s \leq \mu_s N$ . The magnitude of the static friction depends on the types of materials that make up the two surfaces and the magnitude of the compression (normal) force acting on the object.

**H.3.3.3** There are no force laws for some types of contact interactions because the complexity of the interactions does not allow the magnitude of the forces to be easily represented. [SSCS, page 147]

- a. A contact interaction occurs when the surfaces of two solid objects are pressed together because of other interactions on one or both objects (e.g., a solid sitting on or sliding along a table; a magnet attached to a refrigerator). This is called a *compression* interaction. A compression (normal) force applied to an object is always a push directed at right angles from the surface of the other interacting object.
- b. A contact interaction occurs when a cord (e.g., rope, wire, rod) pulls on another object or system and the cord is not slack. A *tension* force on an object always points in the direction the cord is pulling.

**H.3.3.4** In static friction and drag interactions, one of the interacting systems can be an energy source with a moving part (e.g., motor moving the blades of a helicopter; a person's moving foot). When the system with an energy source pushes on another object or system (e.g., the air or the ground), the other object pushes back on the system with equal and opposite force (Newton's third law), which can cause a change in motion of the system with the energy source. [SSCS, page 147]

**H.3.3.5** During contact interactions, forces are not transferred to objects (unlike energy) – the interaction stops as soon as the objects stop touching. Simplifying assumptions are often needed to gain a basic understanding of a real-world situation or to solve a problem (e.g., for contact interactions, "massless" ropes, "frictionless" sliding surfaces, maximum static friction and negligible air resistance).

**H.3.3.6** At the atomic scale, the interaction between the particles (atoms or molecules) of different substances is an electric charge interaction. At this scale, there are no "contact" forces. The strength of the attractive forces between the particles of different substances is different for different pairs of substances, depending on the electron configurations of the atoms or molecules of the two substances. (See Objective 1.3) [SSCS, page 147]

## LEARNING OUTCOMES

Ways in which students engage with and apply the essential knowledge in order to understand the objective:

- Investigate, and make a claim about, the variables (e.g., materials of the surfaces; an object's surface area; velocity of an object; mass or weight of an object) that could affect the kinetic frictional force on an object. Justification is based on the evidence and Newton's second law. [SSCS, page 146]
- Measure and mathematically represent the elastic constant of a linearly elastic object (e.g., a spring, a steel wire, a bungee cord). Measurements and representations are based on data tables, graphs, and the empirical force law for elastic materials. [SSCS, page 146]
- Identify a pair of surfaces and explain why it is best in different situations (e.g., different soled shoes for various surfaces). Justify by using a table of kinetic and static friction coefficients. [SSCS, page 146]
- Predict what happens to the magnitude of the kinetic-friction force in different situations involving a change in the pair of sliding surfaces. Justify the prediction by using a table of kinetic friction coefficients. [SSCS, page 146]
- Analyze problems involving the different types of contact interactions and an identified object of interest.
  - ◆ Identify the types of objects interacting with the object of interest, and observe the changes in motion of each object.



## LEARNING OUTCOMES (9-12), continued

- ◆ Make a claim about the types of contact interactions. Justification is based on the evidence and the defining characteristics of each type of interaction.
- ◆ Represent the forces on the object of interest by drawing a force diagram showing both the vertical and horizontal forces (when appropriate).
- ◆ Explain the observed motion of the object of interest. Justification is based on Newton's second law.
- Give examples of everyday phenomena and/or technological devices in which one of the interacting objects is an energy source. Identify interacting objects (such as an energy source [motor]–moving blades of a helicopter interacting with the surrounding air), and draw a force diagram of the energy-source system. Explain the motion of the energy-source system based on Newton's laws of motion.
- Analyze different problems involving contact interactions to determine whether any simplifying assumptions are needed to solve each problem. Justification is based on the defining characteristics of different types of contact interactions and on knowledge of simplifying assumptions. Solve the problems.
- Explain why the kinetic-friction force and the static-friction force are different for a given pair of surfaces. Justify the explanation by using knowledge of friction interactions and the small-particle model of the forces between the particles of different substances. [SSCS, page 146]
- Explain why the drag force is larger in liquids than in the air. Justify the explanation by using the small-particle model (see Objective 1.3). [SSCS, page 146]
- Evaluate explanations and predictions using the following criteria: (a) the explanation or prediction is complete (all relevant evidence and/or scientific ideas are included); (b) the explanation or prediction is based on evidence and/or correct physics ideas (not opinions); (c) the explanation or prediction is clear and concisely written; and (d) the justification links the evidence and scientific ideas to the claim in a logical manner.

**OBJECTIVE 3.4****GRAVITATIONAL INTERACTION AND FORCES** (Grades 5-8 and Grades 9-12)

*Students understand that gravity is an attractive interaction between any two objects with mass, which can cause a change in the motion of the objects. Gravitational interactions are governed by a force law.*

**BOUNDARY.** *Motions are limited to one dimension and to vertical motions of ordinary objects on Earth, and circular motions of moons and planets. Projectile motion can be done as an extension activity in grades 9-12.*

**Elementary Foundations**

By the end of grade 4, students know that:

Same as Objective 3.2, and in addition:

1. With a few exceptions (e.g., helium-filled balloons), objects fall to the ground no matter where the object is located on Earth.
2. Without touching, the Earth pulls down on all objects with a force called *gravity* or *the gravitational force*.

**Grades 5 - 8**

**Clarification.** Students are introduced to the qualitative defining characteristics of the gravitational interaction. Students in this grade band also distinguish between weight and mass. The field model of the gravitational interaction is developed in Objective 5.1.

**RELATED OBJECTIVES:**  
Forces and Fields  
(P.4.1)

**BOUNDARY.**<sup>†</sup> Excluded are situations of objects on Earth at rest. Comparison of the weight of objects on Earth and other planets and moons is in Objective 5.1 (Forces and Fields).

## ESSENTIAL KNOWLEDGE

Students reason with and apply the following concepts in the learning outcomes:

- M.3.4.1** The Earth is approximately spherical in shape. Like the earth, the sun and planets are approximately spheres. On the surface of the Earth, up and down is the direction of a plumb line – towards the center of the Earth.
- M.3.4.2** The continual attraction that occurs between any two objects with mass is called the gravitational interaction. The evidence of the interaction is a change in motion of one or both objects.
- Each atom of an object is gravitationally attracted to each atom of the interacting object. Thus, the gravitational force on an object is the sum of the forces on each atom of the object. On a force diagram this is represented by drawing the force arrow from the center of the object pointing to the center of the interacting object.
  - Gravitational interactions are difficult to observe unless at least one of the objects is very massive (e.g., the Sun, planet, moon).
  - The magnitude of gravitational forces increases with the masses of the two objects and decreases with the distance between the two objects.
- M.3.4.3** Compared to magnetic and electrical interactions, the gravitational interaction is extremely weak.
- M.3.4.4** “Weight” is the everyday term for the gravitational force (pull) of Earth (or other planet or moon) on objects located on or near Earth’s surface (or surface of other planet or moon). Like all forces, gravitational forces on ordinary objects on Earth are measured with calibrated spring scales that are not moving with respect to the Earth. [SSCS, page94]

## LEARNING OUTCOMES

Ways in which students engage with and apply the essential knowledge in order to understand the objective:

- Given a real world situation involving different objects (including people) located at the poles and/or other locations on the Earth, explain the object’s motion. Justification is based on knowledge of the direction of gravitational interactions.
- Provide evidence, gathered from investigations, print, or electronic resources, which supports the idea that a gravitational interaction is *not* caused by Earth’s magnetism, the Earth’s rotation, or air pressure. [SSCS, page 93]
- Given real-world situations involving gravitational interactions between two objects, and an identified object of interest (e.g., a small falling object, a planet circling a star). (a) Identify the relative masses of the objects involved and the change in motion of each object. (b) Represent the gravitational force on the object of interest by drawing a force diagram.
- Investigate the strength of the gravitational force of Earth, compared to the strength of the magnetic force and of the electrical force. [SSCS, page 93]
  - ◆ Observe and record what happens when a small magnet is held above one or more small-mass objects made of a magnetic material (e.g., paper clips) and when a charged object is held above one or more small-mass objects made of an electric insulator (e.g., small pieces of paper).
  - ◆ Represent the motion of the magnetic-material object(s) and electric-insulator objects with a motion diagram. Represent the forces acting on these object(s) by drawing force diagrams.
  - ◆ Make a claim about the magnitude of the gravitational force compared to the magnetic and electrical forces. Justification is based on the evidence of the change in motion and Newton’s second law of motion.
- Explain (qualitatively) why the gravitational forces between two objects (e.g., two pencils, a person and a car) are not noticeable. Justification is based on the defining characteristics of the gravitational interaction. [SSCS, page 93]

## LEARNING OUTCOMES (5-8), continued

- Explain (qualitatively) the difference between the mass and weight of an object. Justification is based on the defining characteristics of the gravitational interaction. [SSCS, page 93]
- Analyze problems involving the gravitational interaction and the drag interaction for a defined system.
  - ◆ Identify the types of objects interacting with the object of interest, and observe/identify the changes in motion of each object.
  - ◆ Represent the forces on the object of interest by drawing a force diagram.
  - ◆ Explain the observed motion of the object of interest. Justification is based on Newton's second law.

## Grades 9 - 12

*Clarification.* Students are introduced to Newton's universal Law of gravitation (they are not expected to understand the origin of the  $1/r^2$  relationship).

**RELATED OBJECTIVES:** Conservation of Linear Momentum (P.2.2); Forces and Fields (P.4.1); College Board *Standards for College Success™: Mathematics and Statistics*, A1.3.1

**BOUNDARY.**<sup>†</sup> *Situations are limited to vertical motion and uniform circular motion. Projectile motion can be developed as two, one-dimensional problems – constant motion (zero sum of forces) in the horizontal direction and constant acceleration (due to gravitational force) in the vertical direction.*

## ESSENTIAL KNOWLEDGE

Students reason with and apply the following concepts in the learning outcomes

- H.3.4.1** Gravitational, magnetic, electrical and electromagnetic interactions occur continually when objects are not touching, and they do not require an intermediate material (medium). They are called interactions at a distance, or long-range interactions. (Same as in Objective 5.1)
- H.3.4.2** The force law for gravitational interaction, called Newton's universal law of gravitation, states that the strength of the gravitational force is proportional to the product of the two masses and inversely proportional to the square of the distance between the centers of the masses [ $F_G = (G m_1 m_2)/r^2$ ]. The proportionality constant is called a universal constant because it does not depend on any other properties (e.g., chemical composition) of the objects or whether the object is charged or is a magnet). [SSCS, page 148]
- H.3.4.3** When an object's distance from Earth's surface is small compared to Earth's radius, then a simplifying assumption is that the gravitational force on an object depends only on the mass of the object. In this case, objects fall with approximately the same acceleration: 9.8 m/sec/sec. [SSCS, page 148]
- H.3.4.4** When people are in free fall (e.g., some amusement park rides, sky diving, astronaut orbiting the Earth), they feel "weightless" because people do not feel the extremely small gravitational force on each atom in their bodies. When standing, people feel the (normal) force of the ground pushing upwards on their feet, which produces the sensation of weight.

## LEARNING OUTCOMES

Ways in which students engage with and apply the essential knowledge in order to understand the objective:

- Explain why all objects near Earth's surface fall with approximately the same acceleration, despite having different masses and weights. Justify by using the universal law of gravitation and Newton's second law. [SSCS page 148]
- Analyze different problems to determine whether a constant gravitational acceleration can be assumed. Justify the analysis by using the universal law of gravitation. When appropriate, calculate a gravitational force. [SSCS page 148]

## LEARNING OUTCOMES (9-12), continued

- Explain why the spring scale reading for someone standing on a scale in an accelerating elevator is different from the spring scale reading when the elevator is at rest or moving with a constant speed. Justify the explanation by constructing force diagrams of the person and the scale for the different situations (moving up or down with increasing or decreasing velocities) and by using Newton's laws. [SSCS page 148]
- Explain why an astronaut orbiting the Earth feels "weightless," even though the gravitational force of the Earth is still acting on the astronaut. Justify using the knowledge of the human lack of sensation of gravitational forces. [SSCS page 148]
- Explain why the gravitational force on the Earth from an interacting falling object does not result in a measurable acceleration of the Earth. Justify based on the universal law of gravitation and Newton's laws. [SSCS, page 148]
- Predict quantitatively, for the circular orbit of an object (e.g., satellite, planet, moon), the mass of an object or the distance between the objects. Justification is based on the universal law of gravitation.
- Predict algebraically how a change in distance (e.g., triple the distance) between two objects with mass and/or a change in mass (e.g., one-fourth of the mass) of one or both interacting objects changes the gravitational force on an object. Justification is based on the universal law of gravitation. [SSCS, page 148]
- Predict algebraically the position between two objects at which the vector sum of the gravitational forces (net force) on an object is zero (e.g., Earth–Moon system, planet–Sun system). Justification is based on the universal law of gravitation and Newton's second law. [SSCS, page 148]
- Evaluate explanations using the following criteria: (a) the explanation is complete (all relevant evidence and/or scientific ideas are included); (b) the explanation is based on evidence and correct physics ideas (not opinions); (c) the explanation is clear and concisely written; and (d) the justification links the evidence and scientific ideas to the claim in a logical manner.
- Give examples of distances and times to add to a chart for the cosmic scale ( $> 10^{+10}$ ). Investigate the range in sizes that can be seen with the unaided eye, visible light telescopes, and other types of telescopes.

**OBJECTIVE 3.5****MAGNETIC AND ELECTRICAL INTERACTIONS AND FORCES** (Grades 5-8 and Grades 9-12)

*Students understand that both magnetic interactions and electrical interactions occur between mutually attracting or repelling objects, which can cause a change in the motion of the objects. Electrical interactions apply to point charges and are governed by a force law.*

**BOUNDARY.** Two- and three-dimensional forces and motion are excluded.

**Elementary Foundations**

By the end of grade 4, students know that:

1. Without touching them, a magnet pulls on all things made of iron and either pushes or pulls on other magnets. [BSL 4G/E2]
2. Without touching, an object that has been electrically charged by rubbing pulls on all other uncharged objects and may either push or pull other charged objects. [BSL 4G/E3\*]

## Grades 5 - 8

**Clarification.** In grades 5–8, students are introduced to the qualitative defining characteristics of magnetic and electric charge interactions, including the attraction between charged and neutral objects, and the variables that affect the magnitude of the forces between two charged objects.

**RELATED OBJECTIVES:** Electric Circuit Interactions and Energy (4.2), Forces and Fields (5.1); College Board *Standards for College Success™: Mathematics and Statistics*, A1.3.1.

**BOUNDARY.<sup>†</sup>** *The focus should be on the observations of the magnetic and electrical interactions. A discussion of subatomic particles will occur at the 9–12 grade band. Charging by induction is excluded at the 5–8 grade band.*

### ESSENTIAL KNOWLEDGE

Students reason with and apply the following concepts in the learning outcomes:

**M.3.5.1** Magnetic interactions occur when one magnet is close to, or touching, another magnet or a magnetic material (e.g., a substance that contains iron, nickel or cobalt). The evidence of the interaction is a change in motion of one or both objects.

- All bar magnets (e.g., a compass needle) line up in the north–south direction when freely suspended. The end of the magnet that points approximately toward the geographical north is defined as the magnet’s north end. The other end of the magnet that points approximately toward the geographical south is defined as the south end.
- Two magnets with opposite ends near each other will move toward each other (attract). Two magnets with the same ends near each other will move away from each other (repel). A magnet and an object made of magnetic material will move toward each other (attract).
- The magnitude of the magnet–magnetic material force and the magnet–magnet force depend on the strength of the magnet(s) (the more magnetic one or both magnets is, the greater the forces) and on the distance between the two objects (the greater the distance, the weaker the magnetic forces).
- The magnetic force on an object is drawn from the approximate center of the object, and points toward the center of other object (attraction) or away from the center of the other object (repulsion).

**M.3.5.2** Electrical interactions occur when a charged object is close to another charged object or an uncharged object. The evidence of interaction is a change in motion of one or both objects.

- Objects are typically uncharged. Any charged object (e.g., a comb that has been rubbed on a sweater) attracts uncharged objects such as bits of paper or a thin stream of water. Objects can be charged two ways, called positively charged objects and negatively charged objects.
- Two objects with different types of charge will move toward each other (attract). When two charged objects have the same type of charge, they move away from each other (repel). A charged object will move toward an uncharged object (attract).
- The magnitude of the electric charge force depends on the amount of charge on one or both interacting objects and decreases with increasing distance between the charged object and the other charged or uncharged object.
- The electrical force on an object is drawn from the approximate center of the object, and points toward the center of other object (attraction) or away from the center of the other object (repulsion).

**M.3.5.3** In certain materials, charges do not appear to move as freely as charges in other materials. These observations provide evidence that some materials (i.e., conductors) allow electric charge to move easily and that some materials (i.e., insulators) do not allow electric charge to move as freely. [SSCS, page 95]

### LEARNING OUTCOMES

Ways in which students engage with and apply the essential knowledge in order to understand the objective:

- Make a claim concerning which objects, among several objects, are magnets. Justification is based on observational evidence and the defining characteristics of magnetic interactions. If the object is a magnet, use a known magnet to label the ends of the magnet. Use the known magnet to determine which of the objects are made of a magnetic material.

## LEARNING OUTCOMES (5-8), continued

- Make a claim, using simple household materials, about whether an unknown object is charged or uncharged. Justification is based on observational evidence and the defining characteristics of electrical interactions. If the object is charged, use a known charged object to determine whether the object is positively charged or negatively charged.
- Compare and contrast the magnetic and electrical interactions, based on the defining characteristics of each interaction.
- Given real-world situations involving magnetic or electrical interactions between two objects, and an identified object of interest. (a) Identify the type of objects involved in the interaction, and observe the change in motion of each object. (b) Make a claim about the type of interaction (e.g., magnetic or electrical). Claim is based on the evidence and the defining characteristics of each type of interaction. (c) Represent the force on the object of interest by drawing a force diagram. [SSCS, page 94]
- Investigate the motion of charges when different materials (metals and electric insulators) are charged by contact (touching or rubbing). (a) Predict, based on the concept of charges, whether or not charges move when certain materials are charged. (b) Follow a structured protocol for determining whether the charges move and for recording observations on data tables. (c) Analyze and represent data with diagrams. (d) Make a claim, based on the evidence, about whether or not charges move when certain materials are charged. [SSCS, page 94]
- Predict what happens to the magnetic force on an object (decreases, stays the same or increases) when the strength of the magnet changes or when the distance between the magnet and the other interacting object changes. Justification is based on a defining characteristic of magnetic interactions. [SSCS, page 94]
- Predict what happens to the electric force on an object (decreases, stays the same or increases) when the amount of charge changes or when the distance between the two interacting objects changes. Justification is based on a defining characteristic of electric charge interactions. [SSCS, page 94]

## Grades 9 - 12

*Clarification.* Students are introduced to Coulomb's law for point charges (students are not expected to understand the origin of the  $1/r^2$  relationship), and to the atomic-scale explanation for the attraction between charged and neutral objects. Students also explore the conditions necessary for the application of Coulomb's law to solve a problem.

**RELATED OBJECTIVES:** Electric Current Interactions and Energy (4.2); College Board *Standards for College Success™: Mathematics and Statistics*, A1.3.1.

**BOUNDARY.<sup>†</sup>** *This content can be addressed in the same way as it is for students in grades 6–8, but can include more complicated situations and materials. Two- and three-dimensional forces and motion are excluded.*

### ESSENTIAL KNOWLEDGE

Students reason with and apply the following concepts in the learning outcomes: [SSCS, page 150]

- H.3.5.1** At the atomic scale, charge is a property of subatomic particles (e.g., electrons or protons) and is quantized — that is, there is an elementary unit of observable charge that is the charge of the electron.
- H.3.5.2** Two charged objects, which are small compared to the distance between them, can be modeled as point charges. The forces between point charges are proportional to the product of the charges and inversely proportional to the square of the distance between the point charges [ $F_e = (k_e q_1 q_2)/r^2$ ]. This force law is known as Coulomb's law.
- H.3.5.3** For ordinary-size objects, Coulomb's law is difficult to apply. The charged objects must be approximately modeled as point charges and be far apart compared to their size. For the electrical force to be comparable in magnitude to other forces in the problem, the objects must have a small mass (e.g., small pieces of paper or foil) and be close together (e.g., a few inches apart).

- H.3.5.4** All neutral materials contain equal amounts of positive and negative charge. For all methods of charging neutral objects (e.g., rubbing together two neutral materials; charging by contact and charging by induction; using a van de Graff machine or a battery), one object/system ends up with a surplus of positive charge and the other object/system ends up with the same surplus amount of negative charge. These and other experiments support the conservation of charge law:  $\Delta q_{\text{system}} = q_{\text{in}} - q_{\text{out}}$ .
- H.3.5.5** Based on the atomic model, most materials have the same number of electrons and protons; therefore, the materials are electrically neutral. Charged objects can be modeled as having an unequal amount of protons and electrons. When an electrical conductor is charged, the charge “spreads out” over the surface. When an electrical insulator is charged, the excess or deficit of electrons on the surface is localized to a small area of the insulator.
- H.3.5.6** The atomic model also explains why charged objects and neutral objects exert an electrical force on each other.
- When a charged object is near a neutral metal conductor, the free electrons in the metal are attracted toward or repelled away from the external charge. As a result, one side of the conductor has an excess of electrons, and the opposite side has an electron deficit. This separation of charges on a neutral conductor causes an attractive force on the whole neutral conductor.
  - When a charged object is near a neutral insulator, the electron cloud of each insulator atom shifts position slightly so it is no longer centered on the nucleus. The separation of charge is very small, much less than the diameter of the atom. These atoms point approximately toward the external charge. The sum of all the Coulomb forces on each molecule results in an attractive force on the whole insulator.

## LEARNING OUTCOMES

Ways in which students engage with and apply the essential knowledge in order to understand the objective:  
[SSCS, pages 149-150]

- Calculate, using the conservation of charge law, the charge on an object in simple problems.
- Investigate, and make a claim about, the mathematical relationship between the electrical force, the amount of charge of each interacting object, and the distance separating the two charged objects. Justification is based on the evidence and Newton’s laws.
- Investigate and explain the differences between charging electrical conductors and insulators by contact and charging by induction. Justification is based on the evidence, on knowledge of Newton’s second law, and on the defining characteristics of an electrical interaction.
- Explain why, when a metal is charged, the charges “spread out” on the surface of the conductor and quickly stop moving. Justify the explanation by constructing diagrams and by using Coulomb’s law, Newton’s second law and the atomic model of charges in neutral conductors.
- Predict, using a series of diagrams, how a conductor is charged by contact and by induction in different problems. Justification is based on Coulomb’s law, Newton’s second law, the conservation of charge law, and the atomic model of charges in neutral conductors.
- Explain why there is an attraction between a charged object and a neutral insulator or conductor. Justify the explanations by constructing force diagrams and by using Coulomb’s law, Newton’s laws of motion, and the subatomic model of charges in neutral conductors or insulators.
- Analyze different problems to determine whether Coulomb’s law can be used to solve each problem. Justification is based on the conditions necessary for the application of Coulomb’s law. If appropriate, calculate the force on an object, the amount of charge on an object or the separation of two charged objects.
- Predict algebraically the change in the electrical force on a point charge in different problems where the distance between the interacting point charges changes (e.g., one-fourth of the original distance) and/or where the magnitude of the charge of one or both point charges changes (e.g., triple the original charge). Justification is based on Coulomb’s law.

LEARNING OUTCOMES (9-12), continued

- Predict algebraically the position in which a point charge must be placed in a line of two or three other point charges, where the vector sum of the electrical forces (net force) on the point charge is zero. Justification is based on Coulomb's law and Newton's laws of motion.
- Evaluate explanations using the following criteria: (a) the explanation is complete (all relevant evidence and/or scientific ideas are included); (b) the explanation is based on evidence and correct physics ideas (not opinions); (c) the explanation is clear and concisely written; and (d) the justification links the evidence and scientific ideas to the claim in a logical manner.



## STANDARD 4

### ENERGY TRANSFER AND STORAGE

#### **Objective 4.1 Contact Interactions and Energy** (Grades 5-8 & 9-12)

*Students understand that a mechanical energy transfer (work) across the boundary of a system can change the stored kinetic energy, elastic energy, thermal energy, chemical energy, or other types of energy stored within the system*

#### **Objective 4.2 Electric Circuit Interactions and Energy** (Grades 5-8 & 9-12)

*Students understand that the electric charges that flow in the circuit are in the conductors of the circuit. A battery or other source moves electric charges through the circuit but does not create electric charges. An electrical energy transfer from the source of electric current to the electrical device(s) in a circuit can change the energy stored in the system. All electrical devices transfer energy out of the system. The energy changes within the system depend on the properties of the electrical energy source and the electrical device(s) in the circuit.*

#### **Objective 4.3 Mechanical Wave Interactions and Energy** (Grades 5-8 & 9-12)

*Students understand that a mechanical wave from a vibrating source transfers energy through a material to surrounding objects without a transfer of material. Interaction of a mechanical wave with different objects can cause the path of the wave to change. Energy changes within the receiver object depend on the properties of the object.*

#### **Objective 4.4 Radiant Energy Interactions** (Grades 5-8 & 9-12)

*Students understand that radiant energy from a source can be transferred to surrounding objects without a material (medium), and there are two models of how this happens. The energy changes within a receiver object depend on the properties of the object. There is a continuous range of radiant energies, which includes visible light. Humans can only perceive visible light energy — either from a source or that which is reflected off objects — when the light interacts with the eye-brain system.*

#### **Objective 4.5 Heating and Cooling Interactions and Energy** (Grades 5-8 & 9-12)

*Students understand that a thermal energy transfer (heat) from one object to another can change the thermal energies of the objects. The interactions depend on the properties of the materials and on how far the system is from equilibrium. There are three different methods of thermal energy transfer: conduction, convection, and thermal radiation. At a constant temperature in any time interval, the amount of thermal radiation emitted by an object to its surroundings is equal to the amount of thermal radiation absorbed by the object from its surroundings in that same time interval (thermal equilibrium).*

*Interactions of an object with other objects can be described and explained by using the concept of the transfer of energy from one object to another, both within a defined system and across the boundary of the system. Energy transfers across the boundary of a system can change the total energy within the system. In the conservation of energy equation, one or more energy transfers across the system boundary or changes of energy within the system could be applicable, not applicable, or too small of an effect to be measurable, depending on the problem situation.*

Students understand that scientists can describe, explain and predict an event involving different types of interactions (excluding nuclear interactions) by using the concept of energy transfer and the conservation of energy principle. During an interaction between two objects/systems, energy is transferred from one object/system (energy source) to the interacting object/system (energy receiver). In problems involving multiple simultaneous interaction or complex interaction chains, it is convenient to define one object or system of interest<sup>❖</sup> and keep track of the energy transfers into and out of the system from the interactions with objects/systems in the surroundings. When energy is transferred across the boundary of a system, the energy within the system changes. When amounts of energy are measured, energy is always conserved for both open and closed systems.

**CLARIFICATION.** Students explore different methods of energy transfer and different methods of energy storage during contact, electric circuit, mechanical wave, radiant energy [light], and heating and cooling interactions. They develop fluency analyzing and representing real-world situations in terms of energy transfers and energy changes within the defined system. In grades 9-12, students develop the skill of determining the terms in the conservation of energy equation that apply to different problem situations.

In this standard, there is only one conservation of energy equation, and all other energy equations are special cases, such as the work-energy theorem, conservation of mechanical energy, and the first law of thermodynamics (see Standard 2.1 Conservation of Mass, Energy, and Charge).

<sup>❖</sup> Underlined words and phrases are defined in the glossary.

**OBJECTIVE 4.1****CONTACT INTERACTIONS AND ENERGY** (Grades 5-8 and Grades 9-12)

*Students understand that a mechanical energy transfer (work) across the boundary of a system can change the stored kinetic energy, elastic energy, thermal energy, chemical energy, or other types of energy stored within the system.*

**Elementary Foundations**

By the end of the fourth grade, students know that:

1. The way to change how something is moving is to give it a push or a pull. [BSL 4F/P2]
2. Changes in speed or direction of motion are caused by forces. [BSL4F/E1a]
3. The greater the force is, the greater the change in motion will be. The more massive an object is, the less effect a given force will have. [BSL 4F/E1bc]

**Grades 5 - 8**

*Clarification.* Students begin to develop fluency in qualitatively describing contact interactions in terms of a mechanical energy transfer (work) from one system, the energy source, to the interacting system, the energy receiver. Students are also introduced to four methods of energy storage by systems; motion (kinetic) energy; thermal energy, elastic energy, and chemical energy.

**RELATED OBJECTIVES:** Interactions, Systems, and Scale (1.1); Conservation of Mass, Energy, and Charge (2.1); Contact Interactions and Forces (3.3), Heating and Cooling Interactions and Energy (4.5)

**BOUNDARY.<sup>†</sup>** *Problems are limited to events involving horizontal, straight-line contact interactions (see Objective 5.2 for gravitational interactions and energy). All other simultaneous interactions must be negligible. Excluded are situations that require Newton's third law, such as a person who is walking or a car that is moving. The term "work" is not used until grades 9-12 because of the conceptual difficulties students have understanding and using this term.*

**ESSENTIAL KNOWLEDGE\***

Students reason with and apply the following concepts in the learning outcomes:

- M.4.1.1** During an interaction between two objects or systems, energy is transferred from one system (energy source) to the interacting system (energy receiver). The energy of the source decreases and the energy of the receiver increases. There are different methods of energy transfer. [SSCS, page 103]
- M.4.1.2** Mechanical energy transfer occurs when one object (energy source) pushes or pulls another object (energy receiver). The amount of mechanical energy transfer during an interaction depends on the strength of the force (the greater the force, the larger the energy transfer) and the distance the force acts (the greater the distance, the larger the energy transfer). [SSCS, page 104]
- M.4.1.3** A useful analogy (analogue model) for the energy of objects or systems is: Just as material objects are kept stored in containers, energy is "stored" in physical and chemical systems. The different methods of energy storage in a physical system are associated with different observable *changes* that can indicate an increase or decrease of the stored energy when energy is transferred into or out of the system.
- M.4.1.4** There are different methods of storing energy in objects/systems.
- a. Energy can be stored in elastic objects, such as rubber bands or springs. The elastic energy of an object *changes* when it is stretched or compressed.

<sup>†</sup> For further background and instructional guidance, including restrictions in the scope of the content of the learning outcomes for each objective, see Instructional Guidance for Standard 4, page 117.

\* For further clarification of the learning outcomes and essential knowledge statements for each objective, see the *Tables of Common Student Conceptual Difficulties* in Instructional Guidance for Standard 4.

## ESSENTIAL KNOWLEDGE (5-8), continued

- b. Energy can be stored in the motion of objects. Motion (kinetic) energy *changes* when an object's speed changes.
- c. Energy can be stored in a system of chemicals. The chemical energy of a system *changes* when the chemicals are allowed to react and new substances are produced.
- d. Energy can be stored because objects have a temperature and state (solid, liquid, or gas). The thermal energy of an object *changes* when its temperature or state changes.

**M.4.1.5** The oxygen we breathe reacts chemically with digested food in the blood in our muscles (food-oxygen subsystem in humans)<sup>1</sup> when the muscles are used to push or pull on an object and move it some distance. After the push or pull (force) has stopped, the human body has less food in the food-oxygen subsystem, and the chemical energy of the human decreases.

## LEARNING OUTCOMES

Ways in which students engage with and apply the essential knowledge in order to understand the objective:

- Represent, verbally and with a diagram, the energy source, energy receiver, and the direction of energy transfer in simple contact interactions or a chain of interactions (i.e., the object that is energy receiver of first interaction is energy source for second interaction, and so on).  
*[BOUNDARY: Representations do not need to include the type of energy transfer or the changes in the stored energy of the source or receiver.]*
- Investigate the variables that influence the amount of mechanical energy transfer in different real-world situations involving a contact interaction (e.g., the strength of the force; the distance the force act). (a) Identify the energy source and the energy receiver. Predict how changing the variable will influence the amount of mechanical energy transfer. (b) Decide how you will determine the change in the energy transfer (more, less or the same). (c) Gather data and record observations. (d) Make a claim about how the variable influences how much energy is transferred during the interaction.
- Analyze simple, real-world problem situations involving different types of contact interactions between two objects.
  - ◆ Identify or observe changes in each object during the interaction.
  - ◆ Make claims about the direction of the energy transfer and the energy change (decrease or increase) of energy of each interacting object. Justification is based on observations and knowledge of mechanical energy transfer and the characteristics of the different methods of storing energy.
  - ◆ Construct an energy diagram for the interaction.
- Analyze, and represent with energy diagrams, different real-world situations that involve a *chain of contact interactions* and mechanical energy transfers. Justification is based on observations of changes and knowledge of mechanical energy transfer and the characteristics of the different methods of storing energy.

## Grades 9 - 12

*Clarification.* Students extend their knowledge to include mathematical representations of mechanical energy transfer (work), elastic energy and kinetic energy, and they begin to develop the skill of determining the terms in the conservation of energy equation that apply to different problems

**RELATED OBJECTIVES:** Conservation of Mass, Energy, and Charge (2.1); Constant and Changing Linear Motion (3.1); Contact Interactions and Forces (3.3).

**BOUNDARY.**<sup>†</sup> Motion and forces are limited to horizontal one dimension.

<sup>1</sup> The level of sophistication of this knowledge depends on what students have previously learned about respiration in their life science classes.

## ESSENTIAL KNOWLEDGE

Students reason with and apply the following concepts in the learning outcomes:

- H.4.1.1** Energy transfers and energy storage can be measured in many different ways. The units of energy include Joules, calories, and kilocalories.
- H.4.1.2** Mechanical energy transfer (work) is mathematically represented (for constant or average forces) by  $W = \Sigma F \Delta x$ , where  $\Sigma F$  is the vector sum of the external forces (net force) parallel to the direction of motion. When an external force causes a transfer of energy into the system, then  $W = W_{in}$  (“work done on the system”). When an external force causes a transfer of energy out the system, then  $W = W_{out}$  (“work done by the system”). Mechanical energy transfers (work) within and across the boundaries of a system can result in changes in the kinetic, elastic, chemical or thermal energy of the interacting objects. [SSCS, page 158]
- H.4.1.3** If the only significant transfers of energy into or out of a system are caused by contact interactions, then the conservation of energy principle is:

$$\Delta E_{system} = E_{in} - E_{out}$$

$$\Delta E_{kinetic} + \Delta E_{elastic} + \Delta E_{thermal} + \Delta E_{chemical} + \Delta E_{other} = W_{in} - W_{out}$$

where  $\Delta E_{other}$  includes changes in other methods of energy storage (such as “deformation energy” associated with a permanent change in shape of an object).

- H.4.1.4** Depending on the system of interest in a problem, one or more of the energy transfers across the system boundary or energy changes within the system could be applicable, not applicable, or too small of an effect to be measurable. [SSCS, page 158]
- H.4.1.5** The empirical approximation for the change in the stored elastic energy of an object made of elastic material (such as a spring) is  $\Delta E_{elastic} = 1/2 k \Delta x^2$ , where  $\Delta x$  is the distance the elastic object is compressed or stretched from its relaxed length. [SSCS, page 158]
- H.4.1.6** Kinetic energy is the energy of motion and can be mathematically represented by  $E_{kinetic} = 1/2 mv^2$ , where  $v$  is the magnitude of the instantaneous velocity of the object. [SSCS, page 158]

## LEARNING OUTCOMES

Ways in which students engage with and apply the essential knowledge in order to understand the objective::

- Investigate and analyze problems involving different types of contact interactions between two objects defined as a system.
  - ◆ Predict which terms in the conservation of energy equation will be applicable, not applicable or too small to be measurable for a given problem. Prediction is based on the defining characteristics of the different types of contact interactions.
  - ◆ Measure appropriate quantities (e.g., force, mass, distance, elastic constant) needed to confirm or refute the prediction.
  - ◆ Analyze and represent data, including calculations and an energy diagram.
  - ◆ Make a claim about which terms in the conservation of energy equation are not applicable or too small to be measurable. Justification is based on the evidence.
  - ◆ Predict what would happen to a given energy term (increase, stay the same, decrease) in the conservation of energy equation under different conditions for the problem. Justification is based on the terms in the conservation of energy equation.
- Predict the relative energy transfers and energy changes in a system for different problems involving mechanical energy transfers (work) and for different systems of interest. Justify the prediction by using energy diagrams and the conservation of energy equation. [SSCS, page 158]
- Explain and predict algebraically how changing a variable (e.g., the magnitude of a force or the distance over which a force acts) changes the amount of mechanical energy transfer (work) in different problems involving

## LEARNING OUTCOMES (9-12), continued

contact interactions. Justification is based on the knowledge of mechanical energy transfer (work). [SSCS, 158]

- Translate among different representations of energy transfers and changes within a system for different problems (e.g., verbal and/or written descriptions, energy diagrams and the conservation of energy equation). [SSCS, page 157]
- Predict quantitatively velocity, mass, external force, distance a spring is compressed or stretched, or distance over which a force acts in different problems involving contact interactions (changes in stored thermal, chemical or other types of energy are negligible). Justification is based on the application of the conservation of energy equation.

See Objective 2.1 for additional learning outcomes.

## OBJECTIVE 4.2

### ELECTRIC CIRCUIT INTERACTIONS AND ENERGY (Grades 5-8 and Grades 9-12)

*Students understand that the electric charges that flow in the circuit are in the conductors of the circuit. A battery or other source moves electric charges through the circuit but does not create electric charges. An electrical energy transfer from the source of electric current to the electrical device(s) in a circuit can change the energy stored in the system. All electrical devices transfer energy out of the system. The energy changes within the system depend on the properties of the electrical energy source and the electrical device(s) in the circuit.*

### Elementary Foundations

None Expected.

### Grades 5 - 8

*Clarification.* Students are introduced to qualitative ideas about series and parallel circuits, electric current as a flow of charge, and the idea that the charges that flow are in conductors all the time. They develop their skills in constructing and evaluating analogue models.

**RELATED OBJECTIVES:** Contact Interactions and Energy (4.3); Radiant Energy Interactions and Energy (4.4); and Heating and Cooling Interactions and Energy (4.5).

**BOUNDARY.<sup>†</sup>** *Circuits are limited to simple series or parallel circuits. The atomic model of the flow of electrons in metal conductors is not introduced until grades 9 - 12. The first five learning outcomes do not require knowledge of energy transfers and energy storage. The last two learning outcomes require some knowledge of or introduction to mechanical energy transfer (work), thermal energy transfer (heat), and radiant energy transfer (light).*

### ESSENTIAL KNOWLEDGE

Students reason with and apply the following concepts in the learning outcomes: [SSCS, page 105]

- M.4.2.1** An electric circuit interaction occurs when an electrical energy source (e.g., battery, generator, and solar cell) is connected with conducting wires in a complete loop (closed circuit) to an electrical device(s) (e.g., light bulb, motor), which is(are) the energy receiver(s). The evidence of the interaction is an electric current in the circuit. If a circuit loop is broken (open circuit), the electric circuit interaction stops in that loop. [SSCS, page 105]
- Electric current is the flow of charges through the conductors and is measured with an instrument called an ammeter.
  - Electrical conductors (e.g., metals, acidic or salt solutions) are materials through which charges can flow easily. Electrical insulators (e.g., plastic, glass, wood) are materials through which charges cannot flow

## ESSENTIAL KNOWLEDGE (5-8), continued

easily. The electric current through metal wires (conductors) depends on the type of metal, the length of the wire and the diameter of the wire.

- c. Electrical devices can be hooked up to an electrical energy source in two different ways — in series and in parallel. As the number of devices in a single-series loop increases, the electric current in the loop decreases. In a parallel circuit, the electric currents in each loop are the same as they would be if each loop were by itself — the only loop in the circuit.

**M.4.2.2** A useful mental model of charge flow through a circuit and the function of the battery is:

- a. Wires and other conductors in a circuit are always filled with electric charges.
- b. A battery moves electric charge through the circuit but does not create electric charges. When the circuit loop is broken, the charges stop flowing.
- c. The electric current in a circuit loop is the same everywhere within the loop (i.e., electric current is not used up).

**M.4.2.3** Electrical energy transfer is a process that occurs when an electrical energy source (e.g., battery, generator, solar cell) in a circuit transfers electrical energy to the device or devices (energy receiver) in the circuit. The energy of the source decreases. All electrical devices transfer energy out of the system to the surroundings.

- a. Household electrical devices, called “energy converters,” are designed so that the method of energy transfer out of the device is different from the electrical energy input.
- b. In many life processes (e.g., photosynthesis, respiration) the energy transfer into the system is “converted” to a different method of energy transfer out of the system.

## LEARNING OUTCOMES

Ways in which students engage with and apply the essential knowledge in order to understand the objective:

- Make a claim about whether the bulb or bulbs in a given circuit will light. Justification is based on tracing the path of conductors from one end of the battery, through the bulb filament to the other end of the battery and determining whether the circuit is open or closed. [SSCS, page 104].
- Investigate the variables (e.g., the number of series batteries, the length of a wire, the diameter of a wire, the metal composition of a wire) that affect the current flow through a wire. (a) Ask and refine a scientific question about a variable that could affect the current flow through a wire. (b) Follow a structured protocol for observing the current flow through the wire for different values of the variable. (c) Analyze and represent the data on graphs. (d) Make a claim, based on the evidence, about the relationship between the variable and the amount of current. [SSCS, page 104]
- Investigate the electric current in a one-battery, one-bulb circuit.
  - ◆ Predict the relative sizes of the electric current in the wires on each side of the bulb based on a mental model of charge flow through the circuit and the function of the battery.
  - ◆ Follow a structured protocol for observing the relative sizes of the electric current in the wires on each side of the bulb.
  - ◆ Make a claim, based on the evidence, about the relative sizes of the electric current in the wires on each side of the bulb.
  - ◆ Discuss alternative mental models of electric current.
  - ◆ Make a claim about which alternative mental model of electric current best explains the observations.
- Construct an analogue model of the electric current and the function of the battery in a simple electric circuit. Explain how the model is the same and different from the current flow in circuits. Evaluate the model as good or poor based on its usefulness in making sense of (understanding) electric current in circuits.
- Predict the relative sizes of the electric current at different points in a series circuit, and at different points in a parallel circuit. Justification is based on knowledge of the flow of charges in the conductors of a circuit.

## LEARNING OUTCOMES (5-8), continued

- Given a real-world situation involving a simple electric circuit interaction between two objects defined as the system (e.g., battery and motor):
  - ◆ Observe changes in the objects and the surroundings during the interaction.
  - ◆ Make claims about the direction of the energy transfers within the system, changes in the stored energy within the system, and energy transfers into or out of the system. Justification is based on the observations and knowledge of methods of energy storage and energy transfers.
  - ◆ Represent the energy transfers within the system and across the boundaries of the system, and the energy changes within the system by drawing an energy diagram.
  - ◆ Define the system as the electrical device. Represent the energy transfers and energy changes within the system with an energy diagram.
- Explain why many household electrical devices are called energy converters. Justify using knowledge of energy transfers and energy changes within the system.

## Grades 9 - 12

*Clarification.* In grades 9 - 12, students expand their knowledge of electric current to include an atomic model of electric current, and extend their knowledge to include potential difference and Ohm's law. They continue to develop their skill of using the conservation of energy principle to solve problems.

**RELATED OBJECTIVES:** Interactions and Subatomic and Atomic Models (1.3); and Conservation of Mass, Energy, and Charge (2.1).

**BOUNDARY.<sup>†</sup>** Excluded are problems using complicated schematic diagrams of circuits and using Kirchhoff's rules to solve quantitative problems.

### ESSENTIAL KNOWLEDGE

Students reason with and apply the following concepts in the learning outcomes: [SSCS page 160]

- H.4.2.1** The electric current, which is the same everywhere in a circuit loop, is the amount of charge that flows past a given location each second ( $I=q/\Delta t$ ). The measurement unit of current, the ampere (A), is equal to one Coulomb of charge per second (C/s). [SSCS page 159]
- H.4.2.2** Electric charge is conserved in a closed system, such as a circuit. At a branch point (junction), the current flowing into the junction must equal the total current flowing out of the junction (junction rule). [SSCS page 160]
- H.4.2.3** At the atomic scale, a useful mental model of metal conductors has a lattice of positively charged metal ions that are more or less fixed within a conductor, which are surrounded by a "sea" of mobile, negatively charged electrons. Using this model, one can demonstrate that electrons in metals typically "move" a few centimeters per hour, even during high currents. By convention, current is defined as the amount of positive charge that flows past a location each second. [SSCS page 159]
- H.4.2.4** The potential difference ( $\Delta V$ ) across a battery is the *potential energy difference* ( $\Delta E$ ) *per unit charge* that is caused by the chemical reaction in the battery that separates charges on the positive and negative ends of the battery ( $\Delta V_{\text{battery}} = \Delta E/q$ ). Potential difference is a property of the battery and does not depend on the devices in the circuit. The measurement unit of potential difference, the volt (V), is one Joule of energy per Coulomb of charge (J/C).
- H.4.2.5** The electric potential difference across a resistor is given by the product of the current and the resistance ( $\Delta V = IR$ ). [SSCS page 160]
- H.4.2.6** For a system consisting of *resistive* devices in a series circuit, the conservation of energy equation is: [SSCS page 160]



$$\begin{aligned}\Delta E_{\text{system}} &= E_{\text{in}} - E_{\text{out}} \\ \Delta E_{\text{system}} = 0, \quad E_{\text{in}} &= q\Delta V_{\text{battery}}, \quad \text{and} \quad E_{\text{out}} = q\Delta V_1 + q\Delta V_2 + q\Delta V_3 + \dots \\ q\Delta V_1 + q\Delta V_2 + q\Delta V_3 + \dots &= q\Delta V_{\text{battery}} \\ \Delta V_1 + \Delta V_2 + \Delta V_3 + \dots &= \Delta V_{\text{battery}}\end{aligned}$$

It is often more useful to calculate the energy changes and energy transfers per unit of time, which is called power ( $P$ ) for the energy source. The measurement unit of power, the Watt ( $W$ ), is one joule of energy per second ( $J/s$ ).

$$P = \frac{\Delta E}{\Delta t} = \frac{q\Delta V}{\Delta t} = I\Delta V$$

$$\text{So } \frac{q\Delta V_1}{\Delta t} + \frac{q\Delta V_2}{\Delta t} + \frac{q\Delta V_3}{\Delta t} + \dots = \frac{q\Delta V_{\text{battery}}}{\Delta t}$$

$$I\Delta V_1 + I\Delta V_2 + I\Delta V_3 + \dots = P_{\text{battery}}$$

## LEARNING OUTCOMES

Ways in which students engage with and apply the essential knowledge in order to understand the objective:

- Compare the speeds of electrons at different points in a circuit that is made up of sections of metal wire of different diameters, using the atomic mental model of electric current. [SSCS page159]
- Explain how a simple electrical device works. Justify based on a mental model of electric current through conductors. [SSCS page159]
- Investigate the relationship between current and potential difference (voltage) for different circuit devices (e.g., light bulb, motor, commercial resistors). [SSCS page159]
  - ◆ Ask and refine a scientific question about the relationship between current and potential difference for a circuit device.
  - ◆ Measure and record the potential difference for different values of the current.
  - ◆ Analyze and represent the data on a potential difference versus current graph.
  - ◆ Make a claim about the relationship between potential difference and current for the device. Justification is based on the evidence.
  - ◆ Discusses the meaning of the slope for linear potential difference versus current graphs.
- Construct and evaluate analogue models of potential difference in a simple circuit with one electrical device or two devices in series. Evaluation is based on the criteria that the difference between the scientific concept of potential difference and the analogy is unimportant for the purpose of making sense of (understanding) the concept of potential difference.
- Analyze problems involving electric circuit interactions. [SSCS page159]
  - ◆ Select an object/system and a time interval in order to solve the problem.
  - ◆ Identify the transfers of energy into and out of the system, and the changes in energy within the system.
  - ◆ Write the conservation of energy equation for the problem.
  - ◆ Predict what would happen to a given energy term (increase, stay the same, decrease) in the equation under different conditions for the problem. Justification is based on the terms in the conservation of energy equation.
- Calculate the current in various segments or branches of an electric circuit in different problems from the description or schematic diagram of the circuit.
- Predict the value of the current through or potential difference across an element of a circuit in different problems. Prediction is based on knowledge of conservation of energy and charge.

See Objective 2.1 for additional learning outcomes.



**OBJECTIVE 4.3****MECHANICAL WAVE INTERACTIONS AND ENERGY** (Grades 5-8 and Grades 9-12)

*Students understand that a mechanical wave from a vibrating source transfers energy through a material to surrounding objects without a transfer of material. Interaction of a mechanical wave with different objects can cause the path of the wave to change. Energy changes within the receiver object depend on the properties of the object.*

**BOUNDARY.** *The wavelet theory of wave propagation and interactions is excluded.*

**Elementary Foundations**

By the end of grade 4, students know that:

1. Things that make sound vibrate. [BSL 4F/P3] Changing how fast the object vibrates back and forth can vary the pitch of sound.
2. Waves can be made on water by moving objects (e.g., boats) or by moving an object (e.g., finger) up and down at one spot in the water. Waves can be made on stretched ropes or strings moving one end of the rope or string back and forth.

**Grades 5 - 8**

*Clarification.* For students in grades 5 - 8, the mechanical wave properties that are addressed are those that are most easily observed by using simple physical systems such as a string, a long, stiff spring, a slinky or a rope. For periodic waves, these properties are frequency, wavelength, amplitude and wave speed. Students describe and represent mechanical wave interactions with energy diagrams.

**BOUNDARY.**<sup>†</sup> *Refraction, diffraction, and interference of mechanical waves are grades 9 - 12 topics.*

**ESSENTIAL KNOWLEDGE**

Students reason with and apply the following concepts in the learning outcomes: [SSCS, page 106]

- M.4.3.1** A mechanical wave interaction occurs when a vibrating object (energy source) produces a wave disturbance that travels through a material (medium). This wave disturbance transfers energy to an object at a distance (energy receiver) by displacing the material, but not transferring it. Although the material is temporarily displaced, it returns to its original (undisturbed) position. For most everyday systems of interest, the surroundings of the system are also energy receivers.
- a. A mechanical wave requires a material (solid, liquid or gas) in which to travel and is characterized by three variables: frequency, wavelength and amplitude.
  - b. There are two types of waves: transverse waves (e.g., ropes) and compression (longitudinal) waves (e.g., slinky, sound waves). Some waves, such as seismic waves, have both components.
  - c. For a given material (medium), the amount of energy transfer during a mechanical wave interaction in a defined time interval depends on the frequency and amplitude of the vibrating energy source.
  - d. A wave disturbance travels approximately at a constant speed through a uniform material (medium). The speed of the wave depends on the nature of the material (e.g., the wave travels faster through a solid than through a gas). As the frequency ( $f$ ) of a wave through a material increases, the wavelength ( $\lambda$ ) of the wave decreases. The mathematical representation is  $v_{\text{wave}} = \text{constant} = \lambda f$ . The constant wave speed differs depending on the uniform material.
- M.4.3.2** A sound wave traveling through a solid, liquid or gas is an example of a compression (longitudinal) wave. The pitch of a sound wave is related its wave frequency, and the loudness of a sound wave is related its wave amplitude.

## LEARNING OUTCOMES

Ways in which students engage with and apply the essential knowledge in order to understand the objective:

- **Investigate** the relationship between wave speed in a uniform material (medium) and the frequency, wavelength and amplitude of the wave. [SSCS page 105]
  - ◆ Ask and refine a scientific question about the variables that could affect the wave speed.
  - ◆ Gather data on how the wave speed changes when the variable changes.
  - ◆ Analyze and represent the data by using drawings that show the frequency, wavelength and amplitude of a wave for a given time interval before and after a change in the variable.
  - ◆ Make a claim, based on the empirical evidence, about the relationship (if any) between the variable and the wave speed.
  - ◆ Represent and calculate, using a wave drawing and the wave speed equation, the frequency, wavelength, amplitude or wave speed in different situations.
- Investigate the variables that influence sound waves (e.g., medium, including lack of a medium, changes in frequency, changes in amplitude): (a) Ask and refine a scientific question about the variables that could affect the observed sound; (b) Follow a structured protocol to gather and analyze observations; (c) Make a claim, based on the observations, about the variables that influence sound waves.
- Given real-world situations involving mechanical wave interactions between two objects defined as the system:
  - ◆ Identify the wave as a transverse wave or a compression (longitudinal) wave.
  - ◆ Observe changes in the objects and the surroundings during the interaction.
  - ◆ Make a claim about the direction of the energy transfer. Justification is based on evidence of which object is the energy source and which object is the energy receiver.
  - ◆ Represent the energy transfers and the energy changes within the system and in the surroundings with an energy diagram.
- Represent and calculate, given the time interval for a sound wave to travel to and from a fixed object, the distance of a vibrating energy source from a fixed object. Give examples of how some animals and humans use this phenomenon to navigate (e.g., sonar) or to search for objects. [SSCS page 106]
- Predict, qualitatively and quantitatively, what happens to the wave speed when the frequency, wavelength and/or amplitude change in different problems. Justification is based on the relationship among wave speed, frequency and wavelength. For sound waves, interpret changes in the pitch and loudness of the sound.
- Predict what happens to the amount of mechanical wave energy transfer (increases, stays the same, decreases) when the frequency, wavelength and/or amplitude change in different problems. Justification is based on knowledge of the conditions that change the amount of mechanical wave energy transfer. [SSCS page 106]

## Grades 9 - 12

*Clarification.* Students in grades 9 - 12 expand their knowledge of mechanical waves to include refraction, diffraction and the superposition principle, and they continue to develop the skill of determining the terms in the conservation of energy equation that apply to different problems.

**BOUNDARY.<sup>†</sup>** *The wavelet theory of wave propagation and interactions is excluded.*

## ESSENTIAL KNOWLEDGE

Students reason with and apply the following concepts in the learning outcomes: [SSCS pages 161-162]

- H.4.3.1** When the mechanical wave material (medium) is two-dimensional (e.g., surface water waves, surface seismic waves) or three-dimensional (e.g., sound), then the interaction between a wave and another object

## ESSENTIAL KNOWLEDGE (9-12), continued

or boundary with a different material causes the path of the wave to change (bend or change direction). The change in the path of the wave can be represented with ray diagrams.

- Mechanical waves can bounce off of solid barriers. This interaction is called reflection. The law of reflection states that the angle at which a wave approaches the barrier (angle of incidence) equals the angle at which the wave reflects off the barrier (angle of reflection).
- When a mechanical wave travels from one material (medium) into another material, its direction changes. This interaction is called refraction. Since the speed of a wave depends on the material through which the wave travels, both the speed and the wavelength of the refracted wave change.
- Mechanical waves bend around small obstacles or openings. This interaction is called diffraction. The amount of diffraction (bending) increases with decreasing wavelength. When the wavelength is smaller than the obstacle or opening, no noticeable diffraction occurs.

**H.4.3.2** When energy in a mechanical wave ( $E_{\text{incident}}$ ) reaches a barrier or boundary to another material, a portion of its energy is reflected at the boundary ( $E_{\text{reflected}}$ ), and a portion of the energy passes through the boundary into the material ( $E_{\text{material}}$ ). The energy that passes through the material can be transmitted and/or absorbed. For a system consisting of two materials and incident, reflected, and transmitted waves, the conservation of energy principle can be mathematically represented by:

$$\Delta E_{\text{system}} = E_{\text{in}} - E_{\text{out}}$$

$$E_{\text{incident}} - E_{\text{reflected}} - E_{\text{transmitted}} = E_{\text{dissipated}}$$

where  $E_{\text{dissipated}}$  is the energy “dissipated,” absorbed by the material or transferred out of the system due to the interaction of the system with surrounding objects, assuming no other transfers of energy have taken place. When the dissipated energy is so small that it can be neglected, then:

$$E_{\text{incident}} - E_{\text{reflected}} = E_{\text{transmitted}}$$

**H.4.3.3** When two waves traveling in the same material meet, they pass through each other. When the waves pass through each other, the displacements caused by the two waves add algebraically. This phenomenon is called the superposition of waves.

- When the two displacements are in the same direction (same sign), the total displacement of the material is larger than the displacement of either wave (constructive interference).
- When the two displacements are in opposite directions (opposite signs), the total displacement of the material is less than the displacement of the largest amplitude wave (destructive interference).

**H.4.3.4** When an observer and a mechanical wave source move toward each other, the observed frequency is higher; when they move away from each other, the observed frequency is lower. This phenomenon is called the Doppler effect.

## LEARNING OUTCOMES

Ways in which students engage with and apply the essential knowledge in order to understand the objective:  
[SSCS pages 160-161]

- Recognize, for waves in one-, two- and three-dimensional materials, examples of reflection, refraction, diffraction and interference.
- Investigate, and make a claim about, the variables that affect the interaction of mechanical waves with different barriers and boundaries with another material. Analyze and represent observations with a drawing and, when appropriate, with a ray diagram.  
[BOUNDARY: No calculations are required.]
- Explain, using words and drawings, an example of interference (e.g., standing waves, two-source interference patterns). Justification is based on the principle of the superposition of waves.

## LEARNING OUTCOMES (9-12), continued

- Predict, using words and drawings, what happens to a mechanical wave interference pattern in different problems when two slits in a barrier are moved closer together or farther apart, or when the wavelength changes. Justify the prediction based on the observed interference pattern and areas of constructive and destructive interference.
- Give examples of evidence that supports the idea that sound is a wave phenomenon.
- Explain and predict, using words and drawings, what happens to the observed frequency of a wave (increases, stays the same, decreases) in different problems when the observer and the wave source are moving toward each other or moving away from each other. Justify the explanation and prediction based on knowledge of the Doppler effect.
- Analyze energy transfers and stored energy changes in different problems involving a mechanical wave interaction at a barrier or boundary with another material.
  - ◆ Select an object/system and a time interval in order to solve the problem.
  - ◆ Identify the incident mechanical wave energy, and determine what happens to the energy that passes into the material.
  - ◆ Write the conservation of energy equation for the problem.
  - ◆ Predict what would happen to a given energy term (increase, stay the same, decrease) in the conservation of energy equation if the conditions for the problem changed. Justification is based on the terms in the conservation of energy equation.

See Objective 2.1 for additional learning outcomes.

## OBJECTIVE 4.4

### RADIANT ENERGY INTERACTIONS (Grades 5-8 and Grades 9-12)

*Students understand that radiant energy from a source can be transferred to surrounding objects without a material (medium), and there are two models of how this happens. The energy changes within a receiver object depend on the properties of the object. There is a continuous range of radiant energies, which includes visible light. Humans can only perceive visible light energy — either from a source or that which is reflected off objects — when the light interacts with the eye–brain system.*

#### Elementary Foundations

By the end of grade 4, students know that:

1. Light travels and tends to maintain its direction of motion until it interacts with an object or material. Light can be absorbed, redirected, bounced back, or allowed to pass through. [BSL 4F/E3\*\* (ASL)]

#### Grades 5 - 8

*Clarification.* For students in grades 5-8, radiant energy is limited to light energy. Students develop two analogue models for how light energy can travel from a source to a distant receiver (a particle-like model and a wave-like model). They develop fluency in drawing ray diagrams to explain why we can or cannot see certain objects in different in real-world situations, and why objects appear to be different colors.

**BOUNDARY.**<sup>†</sup> *Radiant energy is limited to visible light. Thermal energy transfers (heat) by radiation is in Objective 4.5.*

## ESSENTIAL KNOWLEDGE

Students reason with and apply the following concepts in the learning outcomes:

- M.4.4.1** Radiant energy transfer occurs when radiant energy from a source object (e.g., light bulb, the Sun) travels to an energy receiver some distance away. Radiant energy transfer does not require a material (medium) between the source and the receiver. For most everyday systems of interest, the surroundings of the system are also energy receivers.
- M.4.4.2** Light sources radiate energy continually from each point on the source in all directions. The light travels in straight lines outward until it encounters and interacts with other objects in the surroundings.
- When a beam of light energy interacts with a shiny surface, some of the light is reflected away from the surface in one direction.
  - When light energy interacts with an opaque object (e.g., paper, chair), some of the light reflects off each location of the object *in all directions*. This is called diffuse reflection.
  - Humans can only perceive visible light energy — either from a source or that which is reflected off objects — when the light interacts with the eye–brain system. Light interactions can be represented with ray diagrams (e.g., source to object to eye–brain system).
  - Light energy from the Sun or a light bulb filament is a mixture of all the colors of light (visible light spectrum). The different colors correspond to different energies: from red (lowest energy) to orange, yellow, green, blue and violet (highest energy).
  - When white light hits an object, the pigments in the object reflect one or more colors (radiant energies) in all directions and absorb the other colors (radiant energies).
- M.4.4.3** There are two analogue models of how radiant energy travels through space at the speed of light.
- One model is that the radiation travels in separate packets of energy continuously emitted from a source in all directions. This particle-like model is called the photon model of light energy transfer.
  - A second model is that radiant energy travels like a mechanical wave disturbance that spreads out in all directions from a source. This wave-like model is called the electromagnetic wave model of light energy transfer.
  - Strong scientific evidence supports both the particle-like model and the wave-like model of radiant energy transfer. Depending on the problem scientists are trying to solve, they either use the particle-like model or the wave-like model of radiant energy transfer.

## LEARNING OUTCOMES

Ways in which students engage with and apply the essential knowledge in order to understand the objective:

- Investigate the interaction of light energy with different opaque objects with smooth, shiny surfaces or rough surfaces.
  - ◆ Ask and refine a scientific question about the light interactions with an object(s).
  - ◆ Follow a structured protocol to gather and record observations.
  - ◆ Analyze and represent the observations by drawing an energy diagram and/or a light ray diagram. Justification is based on the evidence.
  - ◆ Make a claim, based on the evidence, about how light energy interacts with the object(s).
- Compare and contrast mechanical wave interactions and light energy interactions.
- Explain, using words, an energy diagram and a light-ray diagram (source, object, eye–brain system), why a person can or cannot see an object in different real-world situations. Justification is based on knowledge of light sources, reflection and diffuse reflection.
- Explain, using words and a light-ray diagram (light source, object, eye–brain system), why an object appears to be a specific color. Justify the explanation by using knowledge of the interaction of white light with the pigments in objects.

## LEARNING OUTCOMES (5-8), continued

- Construct simple physical analogue models of the two ways light energy could travel from a source to a receiver.

## Grades 9 - 12

*Clarification.* In grades 9 - 12, students extend their knowledge to include the full spectrum of radiant energy transfers, as well as refraction, diffraction and interference interactions. Students continue to develop the skill of determining the terms in the conservation of energy equation that apply to different problems.

**RELATED OBJECTIVES:**  
Interactions and Atomic and Subatomic Models (1.3)

Note: The discussion of wave and particle theories of light energy transfer is the only example of the historical development of physics ideas that students explore in these standards. The historical development of ideas about the atom and atomic structure are in the College Board chemistry standards for college success.

### ESSENTIAL KNOWLEDGE

Students reason with and apply the following concepts in the learning outcomes:

**H.4.4.1** Light energy interactions with solid barriers or the interface between two materials exhibit patterns of reflection, refraction, diffraction, and interference similar to the interactions of mechanical waves with barriers and interfaces.

**H.4.4.2** When light energy from a source ( $E_{\text{incident}}$ ) reaches a boundary between materials with different optical properties (such as air to water), a portion of the energy is reflected at the boundary ( $E_{\text{reflected}}$ ), and a portion of the energy passes through the boundary into the material ( $E_{\text{material}}$ ). At such a boundary, the conservation of energy principle can be mathematically represented by: [SSCS page 163]

$$\begin{aligned}\Delta E_{\text{system}} &= E_{\text{in}} - E_{\text{out}} \\ E_{\text{incident}} - E_{\text{reflected}} - E_{\text{material}} &= 0 \\ E_{\text{incident}} - E_{\text{reflected}} &= E_{\text{material}}\end{aligned}$$

**H.4.4.3** The light energy that goes into the material ( $E_{\text{material}}$ ) can be absorbed by the material and transmitted through the material.

$$E_{\text{material}} = E_{\text{absorbed}} + E_{\text{transmitted}}$$

The amount of energy that is absorbed into the material depends primarily on the properties of the material object. For example, the visible light energy that is absorbed into opaque objects (e.g., paper, a chair, an apple) usually results in a small increase in the object's thermal energy. Transparent materials transmit most of the energy through the material.

**H.4.4.4** Despite the fact that there is no observable wave or material through which a wave can travel, a frequency (and wavelength) for radiant energy can be calculated from its wave-like, two-slit interference pattern. The continuous range of radiant energies is organized into the electromagnetic spectrum, which is determined by the frequency (the greater the frequency, the greater the radiant energy). This spectrum is further divided into seven bands: radio (lowest energy band), microwaves, infrared, visible light, ultraviolet, X-rays and gamma rays (highest energy band). [SSCS page 164]

**H.4.4.5** The sun emits radiant energy in all energy bands, but the largest percentages of energy are in the infrared, visible light, and ultraviolet energy bands, with the largest percentage in the visible band.

**H.4.4.6** The history of the particle-like and wave-like models of light energy transfer illustrates the role of evidence in the development of alternative models.

- In the 17th century, both the particle-like model and the wave-like model for light interactions had been proposed. However, scientists tended to favor the particle model because it seemed to explain light interactions better than the wave-like model.

## ESSENTIAL KNOWLEDGE (9-12), continued

- b. In the 18th and 19th centuries, new evidence strongly supported the wave-like model for light interactions, which became the commonly accepted model.
- c. In the 20th century, additional evidence led to a resurrection of the particle-like model because it could explain phenomena that the wave-like model could not. Today, scientists recognize either model as being appropriate for predicting the results of radiant energy interactions, depending on the circumstances.

**H.4.4.7** Light energy passing through a transparent material is absorbed and then reemitted by each atom in its path. Consequently light has a slower speed through materials than the speed of light in a vacuum. The speed of light between atoms, however, is the constant speed of light in a vacuum.

**LEARNING OUTCOMES\***

Ways in which students engage with and apply the essential knowledge in order to understand the objective:

- Give examples of evidence supporting the idea that a prism or diffraction grating does not create the colors of light, but spreads the colors. [SSCS page 163]
- Compare and contrast the different bands of the electromagnetic spectrum of radiant energy, in terms of energy, frequency and wavelength. Give examples of devices or phenomena for each band of the spectrum. [SSCS page 163]
- Investigate and analyze real-world problems involving radiant energy interactions at the interface between two materials. [SSCS, page 163]
  - ◆ Select an object/system and a time interval in order to solve the problem.
  - ◆ Identify the incident and reflected light energy, and determine what happens to the energy that passes into the material. Determination is based on the problem.
  - ◆ Write the conservation of energy equation for the problem.
  - ◆ Predict what would happen to a given energy term (increase, stay the same, decrease) in the conservation of energy equation under different conditions for the problem. Justification is based on the terms in the conservation of energy equation.
- Investigate the history of the two alternative models of radiant energy transfer.
  - ◆ Explain how Isaac Newton (particle model) and Christian Huygens (wave model) answered the following questions: Why does light travel in straight lines? Why can light travel through a vacuum? Why is the angle of incidence equal to the angle of reflection? When light goes from air into glass or water, why does light bend toward the perpendicular to the surface? Why does a prism separate a beam of white light into the colors of the rainbow? Why does red light refract least and violet light refract most?
  - ◆ Explain why, for the next hundred years, most scientists believed that Newton's particle model had the greater explanatory power.
  - ◆ Explain why the experiments of Thomas Young (1803) and Hippolte Fizeau (1851) led scientists to accept the wave model of light.
  - ◆ Give examples of experiments in the early 20th century that revived the particle model of light (e.g., the Michelson-Morley experiment, the photoelectric effect).
- Explain how life on Earth has responded to where the solar radiant energy spectrum peaks.

See Objective 2.1 for additional learning outcomes.

**OBJECTIVE 4.5****HEATING AND COOLING INTERACTIONS AND ENERGY (Grades 5-8 and Grades 9-12)**

*Students understand that a thermal energy transfer (heat) from one object to another can change the thermal energies of the objects. The interactions depend on the properties of the materials and on how far the system is from equilibrium. There are three different methods of thermal energy transfer: conduction, convection, and thermal radiation. At a constant temperature in any time interval, the amount of thermal radiation emitted by an object to its surroundings is equal to the amount of thermal radiation absorbed by the object from its surroundings in that same time interval (thermal equilibrium).*

**BOUNDARY.** *Examples of change of state are limited to simple cases of melting, freezing or boiling (e.g., melting ice, freezing water and boiling water).*

**Elementary Foundations**

By the end of grade 4, students know that:

1. When two objects are rubbed against each other, they both get warmer. In addition, many mechanical and electrical devices get warmer when they are used. [BSL 4E/E1\*]
2. When warmer things are put with cooler ones, the warmer things get cooler and the cooler things get warmer until they are all the same temperature. Heat is transferred from the warmer ones to the cooler ones. [BSL 4E/E2a&b\*]
3. A warmer object can warm a cooler one by contact or at a distance. [BSL 4E/E2c]
4. Heating and cooling can cause changes in the properties of materials, but not all materials respond the same way to being heated and cooled. [BSL4D/E1\*]
5. All materials have certain physical properties, such as strength, hardness, flexibility, durability, resistance to water and fire, and ease of conducting heat. [BSL 4D/E6\*\* (SFAA)]

**Grades 5 - 8**

**Clarification.** Students are introduced to thermal energy and the different mechanisms of thermal energy transfer (heat). They expand the small-particle model of room temperature gases, liquids and solids (Objective 1.3) to include thermal expansion and contraction

**RELATED OBJECTIVES:** Interactions and Atomic and Subatomic Models (1.3); Conservation of Mass, Energy, and Charge (2.1)

**BOUNDARY.<sup>†</sup>** *Examples of changes of state are limited to simple cases of melting or freezing (such as melting ice and freezing water), boiling water (or simulations of boiling or freezing other room-temperature liquid compounds, such as pure alcohols).*

**ESSENTIAL KNOWLEDGE**

Students reason with and apply the following concepts in the learning outcomes:

- M.4.5.1** A heating or cooling interaction occurs when there is a thermal energy transfer (heat) from a warmer object (energy source) to a cooler object (energy receiver). The thermal energy of one or both interacting objects usually increases or decreases. The evidence of a heating or cooling interaction is a change in the temperature or state of one or both objects.
- M.4.5.2** Thermal energy is the energy associated with the mass of a substance, the nature of the material making up a substance and the temperature of a substance.
- a. Thermal energy cannot be directly measured; however, changes in thermal energy can be inferred based on changes in temperature or a change of state. [SSCS page 109]
  - b. The thermal energy of a substance depends on the amount of the substance, whereas the temperature of a substance does not. [SSCS page 109]



- M.4.5.3** Thermal energy transfers (heat) are always from a warm object to a cooler object, unless additional energy is used to reverse the transfer.
- Conduction is a thermal energy transfer that occurs when there is a temperature difference between two objects in contact. The thermal energy transfer stops when the two objects reach the same temperature.
  - Convection is a thermal energy transfer that occurs when a fluid (i.e., a gas or liquid) moves from one location to another in currents within the fluid.
  - Radiation (radiant energy transfer) is a thermal energy transfer that does not require a material (medium) to transfer the energy from the energy source to a distant energy receiver (e.g., the energy from the Sun reaches Earth through empty space, and radiant energy can be radiated from objects to space). [SSCS page 109]
  - A thermal energy transfer to or from an object can result in the expansion or contraction of the object. The expansion or contraction is different for different substances. In general, gases expand or contract much more than solids or liquids.
- M.4.5.4** The small-particle (mental) model of gases, liquids, and solids (Objective 2.2) can be expanded to include heating and cooling interactions:
- Temperature is the measure of the average motion (kinetic) energy of the particles making up a substance. [SSCS page 110]
  - When there is a thermal energy transfer into a substance, the average motion (kinetic) energy of the particles increases, so the average speed of the particles increases. On the average, the spacing between the particles also increases.
  - Thermal energy transfer by conduction occurs when fast-moving particles of a warm substance collide with slower-moving particles of a cooler substance and transfer energy to the slower-moving particles. [SSCS page 110] In thermal energy transfers by convection, the faster-moving particles of the fluid near the warmer object move toward a cooler location (warm convection current) and/or slower-moving particles near cooler objects move toward a warmer location (cool convection current).

## LEARNING OUTCOMES

Ways in which students engage with and apply the essential knowledge in order to understand the objective:

- Predict, given two different amounts of water, which amount of water will boil first when the two are heated at the same rate. Explain, in terms of thermal energy transfer, why the larger amount of water takes longer to boil despite being heated to the same temperature as the smaller amount of water. [SSCS page 109]
- Investigate the variables that influence the final temperature of the objects in a system consisting of a warmer object and a cooler object in contact (e.g., a hot metal cube placed in a Styrofoam cup [with lid] of cool water): (a) Ask and refine a scientific question about a variable that could influence the final temperatures of the objects. (b) Follow a structured protocol to gather and record data and analyze the data. (c) Make a claim, based on the evidence, about how the variable influences the final temperature. (d) Draw an energy diagram for the system.
- Give real-world examples of situations of thermal energy transfer by conduction, convection and radiation. [SSCS page 109]
- Compare and contrast, in terms of movement of particles, how convection and conduction occur.
- Identify, given a real-world example and a defined system (e.g., a hot cup of water sitting on a table, the warming of the ocean in the summer, a metal spoon in hot soup), the mechanisms of thermal energy transfers that are taking place. [SSCS page 109] Draw an energy diagram for the system.  
**BOUNDARY:** *Systems including the sun are excluded because of the nuclear change of energy of the sun.*
- Recognize when small-particle explanations of different examples of thermal expansion or contraction are good or poor, using the criteria: (a) the explanation links the macroscopic observation with the relevant small-particle model idea(s); (b) the explanation is based on the correct small-particle model idea(s), and (iii) the explanation is complete (i.e., no important small-particle model ideas are missing from the explanation).

## LEARNING OUTCOMES (5-8), continued

- Construct explanations, with words and drawings, of different examples thermal expansion or contraction, using the small-particle model of expansion and contraction.

## Grades 9 - 12

*Clarification.* Students extend their knowledge of heating and cooling interactions to include specific heat, thermal conductivities, and the small-particle model explanation of why the temperature remains constant during a change of state. They continue to develop the skill of determining the terms in the conservation of energy equation (first law of thermodynamics) that apply to different problems.

**RELATED OBJECTIVES:**  
Interactions and Atomic  
and Subatomic Models  
(2.2)

**BOUNDARY.**<sup>†</sup> *Changes of state are limited to melting, freezing, and boiling.*

### ESSENTIAL KNOWLEDGE

Students reason with and apply the following concepts in the learning outcomes: [SSCS pages 165-166]

- H.4.5.1** The thermal energy of a system in a given state depends on the temperature of the system (the higher the temperature of a system, the greater its thermal energy) and the mass of the system (the larger the mass of a system, the greater its thermal energy at a given temperature), and is different for different substances with the same mass and temperature.
- H.4.5.2** The small-particle model of thermal energy explains why the temperature of a substance remains constant during a change of state, despite the fact that thermal energy is continually transferred into or out of the substance.
- Small-Particle Model of Melting.* As a solid is heated, the average speed of the vibrating molecules increases. At the melting temperature, the average speed of these vibrating molecules is large enough so that some of the faster-moving molecules start to break free from their fixed positions and move around. As heating continues, more molecules break free from their fixed positions until all the molecules are moving around in the liquid state with the same average speed, and hence the same temperature, as they had just before melting began. For energy to be conserved, the thermal energy of the liquid must be higher than the thermal energy of the solid at the melting temperature.
  - Small-Particle Model of Boiling.* As a liquid is heated, the average speed of the molecules increases. At the boiling temperature, molecules that are close together are sometimes moving so fast that the attractive forces can no longer hold them together. The molecules fly apart into a bubble of vapor. The bubbles rise to the surface and pop open, releasing the vapor into the air. All of the thermal energy transferred during boiling results in breaking the molecules free from their loose connections until all the molecules are moving randomly around in the gas state with the same average speed, and hence the same temperature, as they had just before boiling began. For energy to be conserved, the thermal energy of the gas must be higher than the thermal energy of the liquid at the vaporization temperature.
- H.4.5.3** Thermal conductivity depends on the rate of thermal energy transfer from one end of the object to the other end (for a constant temperature difference and shape). Thermal conductivities of substances can be ranked in order on a continuous scale from good thermal insulators (thermal energy transfer is relatively slow) to good thermal conductors (thermal energy transfer is relatively fast).
- H.4.5.4** The rate at which thermal radiation is absorbed or emitted by a system depends on the system's surface properties (e.g., color, texture, exposed area) and its temperature. Thus, in a given amount of time, black, rough surfaces absorb more thermal energy than smooth, white surfaces (all other variables being equal).
- H.4.5.5** At a constant temperature and in any time interval, the amount of thermal radiation emitted by an object to its surroundings is equal to the amount of thermal radiation absorbed by the object from its surroundings in that same time interval. This process is called thermal equilibrium.
- H.4.5.6** The first law of thermodynamics is a special case of the conservation of energy principle for situations in which the only transfers of energy into and/or out of a system are thermal energy transfers (heat) and/or mechanical

## ESSENTIAL KNOWLEDGE (9-12), continued

energy transfers (work), and the only change of energy within a system is an increase or decrease of thermal energy. This process is mathematically represented by:

$$\Delta E_{\text{system}} = E_{\text{in}} - E_{\text{out}}$$

$$\Delta E_{\text{thermal}} = (Q_{\text{in}} - Q_{\text{out}}) + (W_{\text{in}} - W_{\text{out}})$$

where Q is the amount of thermal energy transferred (heat). Depending on the situation, one or more of the energy transfers across the system boundary could be applicable, not applicable or too small of an effect to be measurable.

**H.4.5.7** The unique thermal properties of water, such as high specific heat and lower density in the solid than the liquid form, have important consequences for Earth systems and life sciences. These unique properties of water are determined by the shape of its molecule and the arrangement of the molecules in liquid and solid form.

### LEARNING OUTCOMES\*

Ways in which students engage with and apply the essential knowledge in order to understand the objective:  
[SSCS, pages 164-165]

- Investigate and make a claim about the relationship between a variable (e.g., temperature, mass of a system, type of material) and the change in the thermal energy of a system for the special case of no change of state and no transfer of mechanical energy across the boundary of the system. Justification is based on the evidence and the conservation of energy principle. Write a mathematical representation of the relationship between the change in thermal energy, the change in the temperature, and the mass of the system.
- Rank in order, based on a data table or experimental results, the thermal conductivity of different materials.
- Construct explanations of real-world problems involving heating and cooling, including: (a) Why do two objects next to each other in a room feel like they are at different temperatures? (b) Why do clothes made of wool or fur keep people warm? (c) Why does a hot object that is left in a room cool down to room temperature? (d) Why doesn't a solid object that is left out in the hot summer Sun all day keep increasing in temperature until it melts? Justifications are based on knowledge of thermal conductivities, thermal radiation and absorption, and thermal equilibrium.
- Rank in order, based on a data table or experimental results, the thermal radiant energy reflection of different materials.
- Explain the experimental results observed in a situation where the variable is the thermal absorption or radiation of the objects being observed.
- Explain qualitatively why the temperature remains constant while an object melts, freezes, or boils, even though there is a continual transfer of thermal energy across the system boundary.
- Analyze problems involving thermal energy transfers (heat) and/or mechanical energy transfers (work) and changes in the thermal energy of a system.
  - ◆ Select an object/system and a time interval in order to solve the problem.
  - ◆ Determine and represent, with an energy diagram, the direction of thermal or mechanical energy transfers across the system boundary and the thermal energy changes within the system.
  - ◆ Make claims about which terms in the conservation of energy equation are applicable, not applicable or are too small to be measurable. Justifications are based on knowledge of methods of thermal energy transfer.
  - ◆ Write the conservation of energy equation for the problem.
  - ◆ Predict what would happen to a given energy term (increase, stay the same, decrease) in the conservation of energy equation under different conditions for the problem. Justification is based on the terms in the conservation of energy equation.

See Objective 2.1 for additional learning outcomes.



## STANDARD 5

### FORCES, ENERGY, AND FIELDS

*Attractive and repulsive interactions at a distance (e.g., gravitational, magnetic, electrical and electromagnetic) can be described and explained using a field model. The field model explains how objects exert attractive and repulsive forces on each other at a distance, and where energy is stored in the system.*

Students understand that one way scientists describe and explain how forces act over a distance without contact (without a mechanism) is by using a field model. In this model, spheres of influence, called “fields,” surround objects. When an object with the appropriate property is placed in the field of another object, the field exerts a force on it (e.g. the magnetic field of a magnet exerts a force on a compass needle).

An object with mass produces a gravitational field, and the gravitational field exerts a force on other objects with mass. An electrically charged object creates an electrical (electrostatic) field, and the electrical field exerts a force on other electrically charged and neutral objects. A magnetic field is produced by a magnet and by moving electrical charges (i.e., electric current), and the magnetic field exerts a force on other magnets, magnetic materials, and moving electrical charges. A changing magnetic field can produce an electric field (Faraday’s Law).

The field model also explains where energy is stored -- in the field around a system of two mutually attracting or repelling objects: gravitational field (potential) energy, electrical field (potential) energy, and magnetic field (potential) energy.

**CLARIFICATION.** The concept of a field is introduced in order to explain force at a distance (what is the mechanism) and where energy is stored in the system. The field concept also allows for the conservation of energy principle to be applied to numerous systems as discussed in other objectives in Standard 4.

Only basic, foundational ideas of the field model are introduced to ensure success in college introductory physics courses.

#### **Objective 5.1 Forces and Fields** (Grades 5-8 and 9-12)

*Students understand that the field model explains how objects exert attractive and repulsive forces on each other at a distance: their fields are the agents of the interaction.*

#### **Objective 5.2 Energy and Fields** (Grades 5-8 and 9-12)

*Students understand that the field model explains where the energy is stored in a system of two mutually attracting or repelling objects -- in the field of the system. Only systems (not single objects) can have field (potential) energies. Energy can be transferred to and from the field of the system.*

#### **Objective 5.3 Electromagnetic Interactions and Fields** (Grades 5-8 and 9-12)

*Students understand that an electromagnetic interaction occurs when a flow of charged particles creates a magnetic field around the moving particles, or when a changing magnetic field creates an electric field.*

**OBJECTIVE 5.1****FORCES AND FIELDS** (Grades 5-8 and Grades 9-12)

*Students understand that the field model explains how objects exert attractive and repulsive forces on each other at a distance: their fields are the agents of the interaction.*

**Elementary Foundations**

By the end of grade 4, students know that:

1. With a few exceptions (e.g., helium-filled balloons), objects fall to the ground no matter where the object is on located on Earth.
2. Without touching, the Earth pulls down on all objects with a force called *gravity* or *the gravitational force*.
3. Without touching them, a magnet pulls on all things made of iron and either pushes or pulls on other magnets. [BSL 4G/E2]
4. Without touching them, an object that has been electrically charged pulls on all other uncharged objects and may either push or pull other charged objects. [BSL4G/E3\*]

**Grades 5 - 8**

*Clarification.* Students are introduced to the field concept in a conceptual fashion starting with simple systems involving magnets and compasses. By analogy, the field idea is introduced for the gravitational interaction. Students begin to develop skills in drawing magnetic and gravitational field diagrams.❖

**RELATED OBJECTIVES:** Gravitational Interactions and Forces (3.4); Electrical and Magnetic Interactions and Forces (3.5)

**BOUNDARY.**<sup>†</sup> *Field diagrams students draw are limited to single objects only (i.e., no diagrams of interacting magnets, planet-sun systems, or interacting charges). Field line diagrams are excluded because of the conceptual difficulties students have understanding and interpreting field lines.*

**ESSENTIAL KNOWLEDGE\***

Students reason with and apply the following concepts in the learning outcomes:

- M.5.1.1** Magnetic, electrical, gravitational, and electromagnetic interactions occur continually when objects are not touching, and they do not require a material (medium) between the two interacting objects. These types of interactions are referred to as action-at-a-distance interactions. [Same as in Objective 3.4]
- M.5.1.2** One reason for a field model is to explain how two mutually attracting and repelling objects can interact at a distance, without touching. In the field model, spheres of influence, called fields, surround attracting and repelling objects.
- M.5.1.3** When an object with the appropriate property is placed in the field of another object, the field exerts a force on it (e.g. a the magnetic field of a magnet influencing a steel nail or a compass needle). The stronger the field, the larger the magnitude of the force exerted by the field on objects placed in the field.
- a. The direction of the magnetic field at any location in space is the equilibrium direction of the north end of a compass placed at that point. The magnetic field strength decreases with increasing distance from the magnet.
  - b. The gravitational field strength at any point in space around a planet (or moon, or star) can be measured by hanging a unit mass on a stationary spring scale. The direction of the gravitational field is the direction of a

❖ Underlined words and phrases are defined in the glossary.

<sup>†</sup> For further background and instructional guidance for each objective, including restrictions in the scope of the content for the learning outcomes, see Instructional Guidance for Standard 5 (starting on page 135).

\* For further clarification of the learning outcomes and essential knowledge statements for each objective, see the objective *Table of Common Student Conceptual Difficulties* the Instructional Guidance for Standard 5.

## ESSENTIAL KNOWLEDGE (5-8), continued

plumb line, toward the center of the object causing the gravitational field. The gravitational field strength decreases with increasing distance from the planet.

- c. Magnetic and gravitational fields can be represented by field diagrams, obtained by plotting field-strength arrows at different locations around the object producing the field.

**LEARNING OUTCOMES**

Ways in which students engage with and apply the essential knowledge in order to understand the objective:

- Investigate and explain how mutually attracting or repelling objects interact at a distance without touching. Justify the explanation based on knowledge of the field model.
- Draw a magnetic field diagram for a magnet, using a compass (or many small compasses).
- Analyze two magnetic field diagrams to determine which magnet has the strongest magnetic field; predict the differences that would be observed when compasses were placed at different locations around each magnet.
- Identify correct and incorrect gravitational field diagrams for a planet or moon. Draw a gravitational field diagram for a planet or moon.
- Analyze two gravitational field diagrams to determine which of two planets has the strongest gravitational field; predict the differences that would be observed when unit masses (1 kg) were hung from spring scales placed at different locations near the surface of the planet.

**Grades 9 - 12**

*Clarification.* Students relate the source of the field with the field itself, along with qualitative descriptions of the direction of the field. Students are also introduced to the mathematical representation of a gravitational field and an electric field.

**RELATED OBJECTIVES:** Gravitational Interaction and Forces (3.4); Magnetic and Electrical Interactions and Forces (3.5).

**BOUNDARY.**<sup>†</sup> *Field line diagrams are excluded.*

**ESSENTIAL KNOWLEDGE**

Students reason with and apply the following concepts in the learning outcomes: {SSCS, page 168}

- H.5.1.1** The field of a particular source (such as Earth) depends only on the properties of the source and the position of an object relative to the source, not on any properties of objects placed in the field (such as a ball). The field of an object is always there, even if the object is not interacting with anything else.
- H.5.1.2** The strength of an object's gravitational field at a certain location is given by the gravitational force per unit of mass experienced by another object placed at that location:  $g = F_g/m$ . The field direction is toward the center of the source. If the gravitational field at a certain position is known, then the gravitational force exerted by the source of that field on any object at that position can be calculated by multiplying the gravitational field strength ( $g$ ) and the mass of the object.
- H.5.1.3** The strength of the electrical field of a charged object at a certain location is given by the electric force per unit of charge experienced by another charged object placed at that location. The direction of the electric field at a certain location is the direction of the electrical force on a positively charged object at that location:  $E = F_e/q$ . If the electric field at a certain position is known, then the electrical force exerted by the source of that field on any charged particle at that position can be calculated by multiplying the electric field strength ( $E$ ) and the charge of the particle.

- H.5.1.4 The field caused by a collection of objects is equal to the vector sum of the fields caused by the individual objects (superposition of fields).

### LEARNING OUTCOMES\*

Ways in which students engage with and apply the essential knowledge in order to understand the objective:

- Calculate the weights of an object on the surfaces of different planets or moons by using a table showing the gravitational field strength (gravitational force per unit of mass,  $g$ ) at the surfaces of the planets and moons. [SSCS page 167]
- Calculate the electric forces on a point charge at different locations, given the magnitude of the electric field at these locations. [SSCS page 167]
- Analyze an electric field diagram for a collection of two or three point charges in a line (with the same charge magnitudes) to determine whether the diagram accurately represents the problem. Explain why the diagram is correct or incorrect. Justification is based on knowledge of field diagrams and electric fields. [SSCS page 168]
- Draw a sketch of the electric field diagram for two point charges, given each charge type, relative charge magnitudes and the distance between the two charges. [SSCS page 168]
- Recognize the electric field diagrams for a dipole, a large sheet of charges (uniform surface charge density) and two large capacitor plates. [SSCS page 168]
- Explain what happens to the magnetic or gravitational field of a source when an object is removed from its field. Justification is based on the field model.
- Explain why the gravitational or electrical force on an object does not depend on the specific properties of the object. Justification is based on the field model.

## OBJECTIVE 5.2.

### ENERGY AND FIELDS (Grades 5-8 and Grades 9-12)

*Students understand that the field model explains where the energy is stored in a system of two mutually attracting or repelling objects -- in the field of the system. Only systems (not single objects) can have field (potential) energies. Energy can be transferred to and from the field of the system.*

**Elementary Foundations.** By the end of grade 4, students know that:

None expected.

### Grades 5 - 8

*Clarification.* Students are introduced to the idea of energy stored in magnetic fields by analogy to the storage of energy in springs and rubber bands. The analogy is then extended to energy storage in gravitational fields.

**RELATED OBJECTIVES:** Gravitational Interactions and Forces (3.4); and Electrical and Magnetic Interactions and Forces (3.5)

**BOUNDARY.†** Field line diagrams are excluded. The term “potential” energy is not used until grades 9 - 12 because of the conceptual difficulties students have understanding and using this term.



## ESSENTIAL KNOWLEDGE

Students reason with and apply the following concepts in the learning outcomes:

- M.5.2.1** When two mutually repelling or attracting objects interact, both objects' kinetic energies change, but since there are no other observable changes in the objects, neither is acting as the energy source or receiver. Instead, the energy is stored in or extracted from the field around the system. The individual objects do not store energy.
- M.5.2.2** During a magnetic interaction magnetic energy is stored in the magnetic field around the system (magnet–magnet or magnet–magnetic object). A change in the separation of magnets is evidence that the magnetic field energy around the system has changed.
- When two magnetically repelling objects are moved close to one another, energy is stored in the field (similar to compressing a spring). When these objects are moved apart, energy is extracted from the field (similar to releasing the spring).
  - When two objects attract one another magnetically, energy is stored in the field by moving the objects apart (similar to stretching a spring), and energy is extracted from the field by allowing them to move closer (similar to releasing the spring).
- M.5.2.3** In the field model, gravitational fields only produce attraction. Gravitational energy is stored in the gravitational field of an Earth–object system. A change in the separation between the objects is evidence that the gravitational field energy of the system has changed. When two attracting masses are moved farther apart, energy is stored in the field. When two attracting masses move closer together, the gravitational field energy decreases.

## LEARNING OUTCOMES

Ways in which students engage with and apply the essential knowledge in order to understand the objective:

- **Explain** why energy is stored in the fields of attracting or repelling objects and not in the objects themselves. Justification is based on the field model of stored energy.
- **Investigate** how the field of two repelling magnets changes: (a) when the magnets are moved closer together, and (b) when they are moved farther apart. Make a **claim** about how the stored field energy changed in each case.
- Investigate how the field of two attracting magnets changes: (a) when the magnets are moved farther apart, and (b) when they are moved closer together. For each case, record the observations and sketch the before and after field diagrams. Make a claim about how the stored field energy changed in each case.
- Predict how the gravitational field changes: (a) when an object is moved at a constant speed from the ground to a height  $h$  above the ground, and (b) when the object is released to fall to the ground. Justification is based on an analogy with attracting magnets and stretching a spring and releasing the spring.
- Compare by ranking the amount of gravitational potential energy stored in an Earth–object system for different positions of the object relative to Earth's surface.
- Compare and contrast the field models for energy stored in gravitational fields and the field model for energy stored in magnetic fields.
- Explain how we know that the gravitational, electric charge, and magnetic interactions are different. Justification is based on the defining characteristics of each interaction. [See also Objectives 3.4 and 3.5]

## Grades 9 - 12

**Clarification.** In grades 9 - 12, the field model of potential energy is expanded to include mathematical representations of gravitational and electrical (electrostatic) potential energies. Students use these concepts as they continue to develop the skill of determining the terms in the conservation of energy equation that apply to easily observable systems.

**RELATED OBJECTIVES:** Conservation of Mass, Energy, and Charge (2.1); Gravitational Interactions and Forces (3.4); and Electrical and Magnetic Interactions and Forces (3.5); Contact Interactions and Energy (4.1)

**BOUNDARY:**<sup>†</sup> Field line diagrams are excluded.

## ESSENTIAL KNOWLEDGE

Students reason with and apply the following concepts in the learning outcomes: [SSCS, page 171]

**H.5.2.1** The energy stored in the field around two mutually attracting or repelling objects is called potential energy (e.g., gravitational potential energy, electric potential energy). A single object does not have potential energy. Only the system consisting of two or more attracting or repelling objects can have potential energy.

**H.5.2.2** For an object close to Earth's surface (where gravitational field strength,  $g$ , is constant), mechanical energy must be transferred into the Earth-object system ( $W_{in}$ ) to lift an object at a constant velocity a distance ( $\Delta y$ ) above a zero reference point. So for energy to be conserved, the gravitational potential energy stored in the field ( $\Delta PE_{grav}$ ) must increase. As the object is lifted it pushes on the air, so mechanical energy is transferred out of the Earth-object system ( $W_{out}$ ):

$$\Delta E_{system} = E_{in} - E_{out}$$

$$\Delta PE_{grav} = W_{in} - W_{out}$$

$$\Delta PE_{grav} = mg\Delta y - W_{out}$$

For objects that are not lifted too far or too fast through the atmosphere, the mechanical energy transfer (work) done to the air is very small and can be neglected.

**H.5.2.3** For falling objects close to Earth's surface and a system defined as Earth and the object, the only mechanical energy transfer (work) is out of the system to the air that is pushed by the falling object. The kinetic energy of the object increases and the gravitational potential (field) energy of the Earth-object system decreases:

$$\Delta E_{system} = E_{in} - E_{out}$$

$$\Delta E_{kinetic} + \Delta PE_{grav} = -W_{out}$$

When the mechanical energy transfer (work) to the air is so small it can be neglected, then:

$$\Delta E_{kinetic} + \Delta PE_{grav} = 0$$

**H.5.2.4** When charge is transferred from an object to another object (e.g., separating strips of tape, rubbing objects against each other, using batteries, or a van de Graff generator), a mechanical energy transfer ( $W_{in}$ ) is required to separate the positive and negative charges, just like energy is required to stretch a spring:

$$\Delta E_{system} = E_{in} - E_{out}$$

$$\Delta PE_{electric} - \Delta E_{other} = W_{in}$$

where  $\Delta E_{other}$  refers to other energy changes within the system (e.g., stored chemical energy of battery, thermal energy from friction).

**H.5.2.5** Whenever mechanical energy is transferred to a system of charged objects and there is no change in kinetic energy and no energy is transferred out of the system, the electric potential energy stored in the system must increase for energy to be conserved. The change in electric potential energy per unit charge is called the *potential difference* ( $\Delta V$ ):

$$\Delta E_{system} = E_{in} - E_{out}$$

$$\Delta PE_{electric} = W_{in}$$

$$\Delta V = \Delta PE_{electric}/q$$

## LEARNING OUTCOMES

Ways in which students engage with and apply the essential knowledge in order to understand the objective:

- Calculate the change in gravitational potential energy of the Earth-object system for different objects at different locations above Earth's surface by using different reference points. [SSCS page 169]

## LEARNING OUTCOMES (9-12), continued

- Identify, for different problems, when the correct system has been selected for describing gravitational or electric potential (field) energies. Justification is based on the field model of potential energy. [SSCS page169]
- Analyze problems involving separating and releasing attracting and repelling objects with the system defined as all the interacting objects (e.g., person separating attracting magnets, releasing repelling charges).
  - ◆ Determine and represent, with an energy diagram, the energy changes within the system and the transfers of energy within and across the boundaries of the system.
  - ◆ Make claims about which terms in the conservation of energy equation are applicable, not applicable or too small to be measurable. Justification is based on the conditions in the problem and knowledge of mechanical energy transfers (work) and magnetic potential energy.
  - ◆ Write the conservation of energy equation for the defined system.
  - ◆ Predict what would happen to a given energy term (increase, stay the same, decrease) in the conservation of energy equation under different conditions for the problem. Justification is based on the terms in the conservation of energy equation.
- Analyze problems involving lifting objects at a constant speed or falling objects near Earth's surface, with the system defined as the Earth and the object. [SSCS page169]
  - ◆ Determine and represent, with an energy diagram, the energy changes within the system and the transfers of energy within and across the boundaries of the system.
  - ◆ Make claims about which terms in the conservation of energy equation are applicable, not applicable or too small to be measurable. Justification is based on the conditions in the problem and knowledge of mechanical energy transfers (work) and gravitational potential energy.
  - ◆ Write the conservation of energy equation for the Earth-object system.
  - ◆ Predict what would happen to a given energy term (increase, stay the same, decrease) in the conservation of energy equation under different conditions for the problem. Justification is based on the terms in the conservation of energy equation.
  - ◆ Define the system as one of the interacting objects. Make and justify claims about which terms in the conservation of energy equation are applicable, not applicable or too small to be measurable.
  - ◆ Write the conservation of energy equation for the defined object.
- Analyze problems involving different methods of separating charges, with the system defined as the two interacting objects (e.g., a rubber rod rubbed with fur, then fur and rod separated). [SSCS page169 - 170]
  - ◆ Determine and represent, with an energy diagram, the energy changes within the system and the transfers of energy within and across the boundaries of the system.
  - ◆ Make claims about which terms in the conservation of energy equation are applicable, not applicable or too small to be measurable. Justification is based on the conditions in the problem and knowledge of mechanical energy transfers (work) and electric potential energy.
  - ◆ Write the conservation of energy equation for the defined system.
  - ◆ Predict what would happen to a given energy term (increase, stay the same, decrease) in the conservation of energy equation under different conditions for the problem. Justification is based on the terms in the conservation of energy equation.
  - ◆ Define the system as one of the interacting objects. Make and justify claims about which terms in the conservation of energy equation are applicable, not applicable or too small to be measurable.
  - ◆ Write the conservation of energy equation for the defined object.
- Translate between representations (e.g., verbal description, energy diagrams and the conservation of energy equation) of energy transfers and energy changes in a defined system for problems involving lifting or falling objects or changing the separation between the charged objects. [SSCS page169]

**OBJECTIVE 5.3****ELECTROMAGNETIC INTERACTIONS AND FIELDS** (Grades 5-8 and Grades 9-12)

*Students understand that an electromagnetic interaction occurs when a flow of charged particles creates a magnetic field around the moving particles, or when a changing magnetic field creates an electric field.*

**Elementary Foundations**

By the end of grade 4, students know that:

1. Without touching them, a magnet pulls on all things made of iron and either pushes or pulls on other magnets. [BSL 4G/E2]
2. Without touching them, an object that has been electrically charged pulls on all other uncharged objects and may either push or pull other charged objects. [BSL4G/E3\*]

**Grades 5 - 8**

*Clarification.* Grades 5 - 8 includes electromagnetic interactions as they relate to motors and generators because of the importance of these ideas in understanding the production of electricity and the application of the ideas in environmental science. Electromagnetism is approached in an empirical and qualitative fashion without specific reference to fields.

**RELATED OBJECTIVES:**

Electric Circuit Interactions and Energy (4.4); Electrical and Magnetic Interaction and Forces (3.5)

**ESSENTIAL KNOWLEDGE**

Students reason with and apply the following concepts in the learning outcomes:

- M.5.3.1** An electromagnetic interaction occurs when a magnet and a nearby current-carrying wire exert forces on each other. The evidence of the interaction is a change in motion of the magnet, the wire, or both. This interaction is the basis for the design of a motor.
- M.5.3.2** Another type of electromagnetic interaction occurs when a magnet and a wire loop move relative to each other (e.g., magnet is moves, the coil moves, or both move). The evidence of the interaction is an electric current appears in the wire loop. This interaction is the basis of an electric generator.

**LEARNING OUTCOMES**

Ways in which students engage with and apply the essential knowledge in order to understand the objective:

- **Investigate** and make a **claim** about the connection between electrical and magnetic interactions: Justification is based on the observed evidence and knowledge of electrical and magnetic interactions.
- Investigate the variables that influence the size of the magnetic force on the rotating coil of a motor (e.g., the amount of electric current in the wire coil, the number of loops of wire making up the coil; and the distance between the magnet and coil).
  - ◆ Ask and refine a **scientific question** about a variable that could affect the magnetic force on the rotating coil.
  - ◆ Follow a structured protocol for observing changes in the magnetic force for different values of the variable.
  - ◆ Analyze and represent the data on graphs.
  - ◆ Make a claim, based on the evidence, about the relationship between the variable and the magnetic force on the rotating coil of a motor.
  - ◆ Explain how the motor works, and suggest improvements to the design.
- Analyze a simple generator, explain how it works, and suggest improvements to the design.

## LEARNING OUTCOMES (5-8), continued

- Predict and investigate, for different orientations of a magnet and a current-carrying wire, whether the magnet exerts a force on the current-carrying wire. Make a claim about which orientations of the magnet result in a force on the current-carrying wire.
- Distinguish between examples where there is relative motion between a magnet and a closed-loop wire or coil, and examples where the magnet and the wire or coil are both in motion, but not in motion relative to each other.

## Grades 9 - 12

*Clarification.* Students extend their knowledge with qualitative ideas about changing electric and magnetic fields, including Faraday's law of induction.

**RELATED OBJECTIVES:** Forces and Changes of Motion (P.3.2); Electrical and Magnetic Interactions and Forces (3.5); Electric Current Interactions and Energy (4.2); and Radiant Energy Interactions (4.4).

## ESSENTIAL KNOWLEDGE

Students reason with and apply the following concepts in the learning outcomes: {SSCS page 172-173}

- H.5.3.1** Electric current and magnetic interactions are closely related, even though they appear to be distinct from each other. The interaction between electricity and magnetism is referred to as an electromagnetic interaction. A basic component of technology is the use of electromagnetic interactions to “convert” mechanical energy into electrical energy and vice versa.
- H.5.3.2** A flow of charged particles (including an electric current in a wire) creates a magnetic field around the moving particles or the current-carrying wire. The evidence of the interaction is a change in motion of a nearby magnet or a change of the flow of charged particles in the presence of a magnet.
- H.5.3.3** A moving charged particle interacts with a magnetic field. For this interaction:
- The magnetic force that acts on a moving charged particle is perpendicular to both the magnetic field and to the direction of motion of the charged particle.
  - The magnitude of the magnetic force depends on the speed of the moving particle, the magnitude of the charge of the particle, the strength of the magnetic field, and the angle between the velocity and the magnetic field.
  - There is no magnetic force on a particle moving parallel to the magnetic field.
  - Moving charged particles in magnetic fields typically follow spiral trajectories. Earth's magnetic field shields the Earth from high-energy charged particles (known as cosmic rays) by deflecting them away from Earth. Moving charged particles can also be trapped in the magnetic field of an object such as Earth. The Van Allen radiation belts are regions of high-energy particles trapped in Earth's magnetic field.
- H.5.3.4** A *changing* magnetic field creates an electric field (while the magnetic field is changing). For this interaction:
- If a closed conducting path such as a wire occupies the space where the magnetic field is changing, the electric field may cause the flow of a changing electric current (evidence of the interaction). This is known as Faraday's law of induction.
  - A changing magnetic field can be created through a closed-loop wire when a magnet and the loop move relative to each other. The magnitude of the induced electric current depends on the strength of the magnetic field, the speed and direction of the relative motion, and the configuration of the wire.
- H.5.3.5** A changing electric field creates a magnetic field, and a changing magnetic field creates an electric field. Thus, one model of radiant energy is an electromagnetic wave in which a pattern of changing electric and magnetic fields propagates at the speed of light.

## LEARNING OUTCOMES

Ways in which students engage with and apply the essential knowledge in order to understand the objective:  
[SSCS page172]

- Investigate, and make a claim about, the variables that affect the magnitude of the induced electric current created by a changing magnetic field. Justification is based on the evidence and Faraday's law of induction.
- Explain why an electric current in a loop of wire, which is not connected to a battery, is detected when the wire is near a changing magnetic field. Justification is based on Faraday's law of induction.
- Explain the role of magnets and coils of wires in the functioning of microphones, speakers, generators and/or motors. Justification is based on the defining characteristics of electromagnetic interactions.
- Predict whether or not there will be an electromagnetic force on two current-carrying wires in different situations. Justification is based on the defining characteristics of electromagnetic interactions.
- Explain qualitatively why radiant energy creates electric currents in conductors. Justification is based on the defining characteristics of electromagnetic interactions.
- Predict whether there will be more cosmic rays trapped at the equator or at the poles of Earth. Justification is based on the defining characteristics of electromagnetic interactions.

## USING THE INSTRUCTIONAL GUIDANCE FOR EACH STANDARD

### Instructional Guidance for Standard 1: Interactions, Models, and Scales

- 1.1 Interactions, Systems, and Scale (5-8)
- 1.2 Interactions and Properties (5-8)
- 1.3 Interactions and Atomic and Subatomic Models (5-8 and 9-12)
- 1.4 Interactions and Objects Moving Very Fast (9-12)

### Instructional Guidance for Standard 2: Conservation Principles

- 2.1 Conservation of Mass, Energy, and Charge (5-8 and 9-12)
- 2.2 Conservation of Linear Momentum (9-12)
- 2.3 Nuclear Interactions and the Conservation of Mass-Energy (9-12)

### Instructional Guidance for Standard 3: Newton's Laws of Motion

- 3.1 Constant and Changing Linear Motions (5-8 and 9-12)
- 3.2 Forces and Changes in Motion (5-8 and 9-12)
- 3.3 Contact Interactions and Forces (5-8 and 9-12)
- 3.4 Gravitational Interactions and Forces (5-8 and 9-12)
- 3.5 Magnetic and Electrical Interactions and Forces (5-8 and 9-12)

### Instructional Guidance for Standard 4: Energy Transfer and Storage

- 4.1 Contact Interactions and Energy (5-8 and 9-12)
- 4.2 Electric Circuit Interactions and Energy (5-8 and 9-12)
- 4.3 Mechanical Wave Interactions and Energy (5-8 and 9-12)
- 4.4 Radiant Energy Interactions (5-8 and 9-12)
- 4.5 Heating and Cooling Interactions and Energy (5-8 and 9-12)

### Instructional Guidance for Standard 5: Forces, Energy, and Fields

- 5.1 Forces and Fields (5-8 and 9-12)
- 5.2 Energy and Fields (5-8 and 9-12)
- 5.3 Electromagnetic Interactions and Fields (5-8 and 9-12)

Each standard is divided into sections, one for each objective (see sidebar). These sections provide minimal guidance for interpreting the learning outcomes (LOs) and essential knowledge (EK) statements in each objective, especially the *difference* in the level of intellectual abstractness and sophistication of reasoning expected at the middle school and high school levels. The purpose of the Instructional Guidance is to provide middle school, high school, and college instructors with sufficient guidance to understand the types of events and tasks in which students engage to meet the goals of each objective.

Three items in each objective guide the interpretation of the LOs and EK statements. The first is a *Table of Common Student Conceptual Difficulties* for the content of the objective. The table also includes the specific LOs and EK statements that most directly provide an opportunity for teachers to address the conceptual difficulty. The research literature in students' conceptual difficulties guided the writing of the learning outcomes and essential knowledge statements. Consequently, the table may also facilitate understanding some ideas in the EK statements that are not found in most state standards. For example, many students believe that a force (e.g., throwing a ball) is imparted to the object that is pushed or pulled. Consequently, an EK statement is:

Grades 5-8. During contact interactions, forces are not transferred to objects (unlike energy) — the interaction stops as soon as the objects stop touching. [M.3.3.3]

The second item of instructional guidance is a *Table of Content Boundaries* for each grade-level band. These tables describe the bounds and depth of knowledge for each grade-level band. They identify objects and phenomena appropriate for the learning outcomes. Any special limitations for specific learning outcomes are also described. In addition, the tables summarize the models and representations expected and excluded, and the technical terms introduced in the objective.

Finally, most objectives include some example questions or problem situations for a few of the learning outcomes. These example problems are intended to facilitate the understanding of how the essential knowledge is to be developed and used through reasoning and in problem solving. For the most part, the examples reflect tasks that are typically *not* found in textbooks. It should be noted that the examples are only a few of the many questions and problem situations that could be used to meet the goals of each objective.

## GUIDE TO USING THE INSTRUCTIONAL GUIDANCE FOR EACH OBJECTIVE

### OBJECTIVE 2.1 CONSERVATION OF MASS, ENERGY, AND CHARGE (Grades 5-8 and Grades 9-12) continued

#### Grades 9-12

The approach taken to the conservation of energy equation is similar to that of John Jewett (2008d) in his article Energy and the Confused Student: A Global Approach to Energy:

"It is my position in this article that there is only one fundamental energy equation and that all other energy equations are special cases. The fundamental equation is called the conservation of energy equation or the continuity equation for energy, both of which can be abbreviated as CEE:

$$\Delta E_{\text{system}} = \Sigma T,$$

where T represents the amount of energy transferred (T for transfer) across the boundary of the identified system by a given mechanism. The general conceptual basis of the equation is this: the only way the total energy ( $E_{\text{system}}$ ) of a system can change is if energy crosses the system boundary by one or more mechanisms described by T. The mathematical basis is this: the total change in energy of the system during some time interval is exactly equal to the net amount of energy crossing the system boundary. The summation sign indicates that energy may cross the boundary by several methods. . . ." [page 210]

#### Table of Common Student Conceptual Difficulties

Student Difficulty. Students often believe that	Where Addressed	
	Essential Knowledge	Learning Outcome
1. All energies are the same. a. Energies are always the same (electrical, kinetic, thermal, etc) for all defined systems and time intervals. [Because one form of energy can always be transformed into another form of energy.] b. There are no energy terms for transfer (energy in transit from one location to another) that are different from the energies that objects can have.	H.2.1.1 H.2.1.2 H.2.1.4	H.B.3 H.B.4 H.B.5
2. Energy is only conserved in a closed system. When the system is open, energy can sometimes disappear. [Things, like light bulbs, "use up" energy.]	H.2.1.1	H.B.2
3. There is nothing special about the conservation of energy – all quantities are conserved in a closed system.	M.2.1.4	M.B.3
4. The conservation of energy is useless; it does not help think about or solve problems (qualitatively or quantitatively).	H.2.1.1	H.B2
5. The conservation of mass, charge, and energy are not fundamental principles of science.	H.2.1.6	H.B.7

#### Table of Content Boundaries

PHENOMENA, REPRESENTATIONS AND MODELS, AND TECHNICAL VOCABULARY High School (Grades 9-12)							
<b>OBSERVATIONS/PHENOMENA (Real World)</b>							
<ul style="list-style-type: none"> <li>• Objects and events similar to Objectives 4-1 through 4.5, and Objective 5.2. However, situations involve multiple interactions (contact, gravitational, electrical, electric circuit, radiant, and thermal interactions).</li> <li>• <b>H.B.2. Methods of energy storage</b> within a system include (See Objectives 4.1 through 4.5):                             <table style="width: 100%; border: none;"> <tr> <td style="width: 50%;">- kinetic energy</td> <td style="width: 50%;">- gravitational potential energy</td> </tr> <tr> <td>- thermal energy</td> <td>- electric potential energy</td> </tr> <tr> <td>- elastic energy (e.g., spring)</td> <td>- magnetic potential energy</td> </tr> </table> </li> </ul>		- kinetic energy	- gravitational potential energy	- thermal energy	- electric potential energy	- elastic energy (e.g., spring)	- magnetic potential energy
- kinetic energy	- gravitational potential energy						
- thermal energy	- electric potential energy						
- elastic energy (e.g., spring)	- magnetic potential energy						

**Introductions** describe any approaches to the content that are not traditional but are supported by cognitive and educational research. References are usually included.

**Table** lists students' common conceptual difficulties with the objective content from physics education research (see Research Base for *Tables of Common Student Conceptual Difficulties* in Appendix B). Also listed are the EK statements and Los that provide the opportunity for teachers to address each conceptual difficulty.

**Learning Outcomes** are identified by grade level (M for middle school, H for high school), and the bullet number of the learning outcome. For example, H.B.3 indicates high school, third bulleted learning outcome.

**Boundaries Table** lists the objects and events that limit the content of the objective. Other boundaries for specific LOs are also listed.



## GUIDE TO USING THE INSTRUCTIONAL GUIDANCE FOR EACH OBJECTIVE (continued)

**Representations/Models** describes the analogue and mental models in the objective. It also describes visual and mathematical representations of ideas, and special mathematical symbols introduced.

**Technical Vocabulary** specifies the technical vocabulary for the objective, as well as any exclusions.

**Final sections** provide some examples to facilitate understanding of level of intellectual abstraction and sophistication required for the grade-level band. The examples tend to differ from those found in traditional textbooks. Of course, specific wording in the examples is not required. Learning outcomes (LOs) are identified by grade band and bullet number (e.g., M.B.2).

### PHENOMENA, REPRESENTATIONS AND MODELS, AND TECHNICAL VOCABULARY

#### High School (Grades 9-12)

**Methods of energy transfer** include (See Objectives 4/1 through 4/5):

- mechanical energy transfer (work)
- mechanical wave energy transfer
- thermal energy transfer (heat)
- electrical energy transfer in circuits, and
- radiant energy transfer (EM)

**Exclusions:** two- and three-dimensional forces

#### REPRESENTATIONS/MODELS

- More complex **analogue models** can be considered for the conservation of energy: for example, a banking account that includes savings, investments with dividends, interest charges, etc. See comments below for H.2.1.1.
- Symbol  $\Delta$  to represent "change in."
- Mathematical model of energy conservation ( $\Delta E_{\text{system}} = E_{\text{in}} - E_{\text{out}}$ )
- Mathematical model for mass-energy equivalence:  $E_{\text{out}} = \Delta mc^2$
- **Energy diagram** (see description below)

#### TECHNICAL VOCABULARY

- conservation of energy principle

#### H.B.2 Example Problem

Event: A battery is connected to a switch and bulb.

- (a) System of interest is the complete circuit; time interval is the tiny (unnoticeable) time after the switch is closed and while the bulb's brightness is increasing. The energy change within the system is a decrease in the chemical energy of the battery and an increase in the thermal energy of the bulb filament (because the temperature of the bulb filament is increasing).\* There is a transfer of radiant energy (mostly visible light and infrared) out of the system. [Note: A heat conduction energy transfer is much slower than a radiant energy transfer, so for this tiny time interval, it can be ignored.]
- (b) System of interest is the bulb filament; time interval is the tiny (unnoticeable) time after the switch is closed and while the bulb's brightness is increasing. The energy change within the system is an increase in the thermal energy of the bulb filament (because the temperature of the bulb filament is increasing).\* There is a transfer of electrical energy into the bulb filament (from the battery) and a radiant energy transfer out of the system.
- (c) System of interest is the bulb filament; time interval is a few minutes while the bulb brightness is not changing. There is a transfer of electrical energy into the system and a transfer of radiant energy out of the system. There is no change in energy of the filament. (Changes in the internal energy of the bulb filament are ignored at the high school level.)

#### Energy Diagrams

There are, of course, many different ways of drawing energy diagrams. The most extensive discussion is by Greg Swackhamer in his paper *Cognitive Resources for Understanding Energy*.

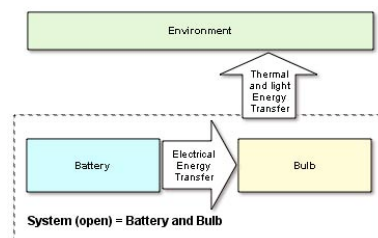

Some diagrams show the transfers of energy

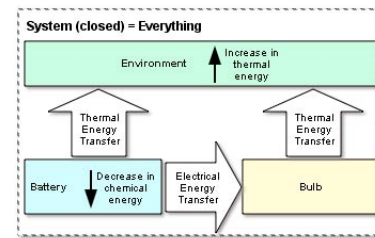

Some diagrams show changes of stored energy



## INSTRUCTIONAL GUIDANCE FOR STANDARD 1. INTERACTIONS, MODELS, AND SCALE

*Changes in the natural world are the result of interactions. The description, explanation, and prediction of interactions depend on the size and time scale and our models of the structure of matter. For objects moving very fast, the macro (human) scale ideas of absolute time and space must be revised.*

### OBJECTIVE 1.1 INTERACTIONS, SYSTEMS, AND SCALE (Grades 5-8)

*Students understand that observed changes in our world are the result of interactions. The description, explanation, and prediction of interactions during a time interval depends on the defined system and the size and time scales involved [cosmic, macro (human) and the atomic and subatomic domains of magnitude].*

In 1969, Robert Karplus wrote in his book *Introductory Physics: A Model Approach*:

“Pieces of matter, objects, that influence or act upon one another are said to interact. The changes that occur in their form, temperature, arrangement, and so on, as a result of the influence or action are evidence of interaction. For the study of interaction, pieces of matter are mentally grouped into systems to help the investigator focus his attention on their identity. As he gathers evidence of interaction, the investigator compares the changes he observes with what would have happened in the absence of interaction. Sometimes he may carry out controlled experiments to discover this; at other times he may draw on his experience or he may make assumptions.”

This approach is followed in all the physics standards.

#### **Table of Common Student Conceptual Difficulties**

Student Difficulty. <sup>‡</sup> Students often believe that:	Where Addressed	
	Essential Knowledge	Learning Outcome
1. Interactions		
a. Observed changes are associated with the innate properties of objects, and are not caused by the interaction of the object with another object.		M.B.1
b. Observed changes in an object occur spontaneously. They are not caused by the interaction of the object with other object(s).	M.1.1.1 M.1.1.3	M.B.4 M.B.5
c. Events can be described and interpreted by noting the qualities of the separate objects involved rather than by seeing the interactions between the objects involved.		
2. The description of an event is the same for all systems and time intervals.	M.1.1.4	M.B.3
3. A system of objects must be doing something (interacting) in order to be a system.	-----	M.B.5

<sup>‡</sup> See also conceptual difficulties in Objective 2.1 (Conservation of Mass, Energy, and Charge)

#### **Table of Content Boundaries**

PHENOMENA, REPRESENTATIONS AND MODELS, AND TECHNICAL VOCABULARY
Middle School (Grades 5-8)
<p><b>OBSERVATIONS/PHENOMENA</b> (Real World)</p> <ul style="list-style-type: none"> <li>• <b>M.B.1.</b> Events are limited to simple, everyday activities, such as tearing a piece of paper with hands, cutting paper with scissors, writing with a pencil, throwing or kicking a ball, stretching a rubber band or spring, using a rubber band as a sling shot, hammering a nail, drilling a hole in wood, using an electrical blender or mixer, and so on.</li> <li>• <b>M.B.4.</b> Devices can include any broken household devices, such as blenders, mixers, graters, a garlic press, can opener (plugs cut off electrical devices); old tools, such as drills, wrenches, anything with gears (plugs cut off electrical devices).</li> </ul>

**PHENOMENA, REPRESENTATIONS AND MODELS, AND TECHNICAL VOCABULARY**

**Middle School** (Grades 5-8)

- **M.B.6.** Chart (logarithmic) should center on  $10^0$ , and extend to either side into the cosmic and atomic scale as far as students are knowledgeable (e.g., age of the dinosaurs, size of our solar system, size of a virus, and so on).

**REPRESENTATIONS/MODELS**

- Chart of domains of magnitude of distance and time.
- Diagrams of interactions (see example below).
- Scientific notation limited to powers of ten.

**TECHNICAL VOCABULARY**

- interaction
- system and subsystem
- system of interest

Underlined words and phrases are defined in the Glossary.

**Example of a Domains of Magnitude Chart (full chart)**

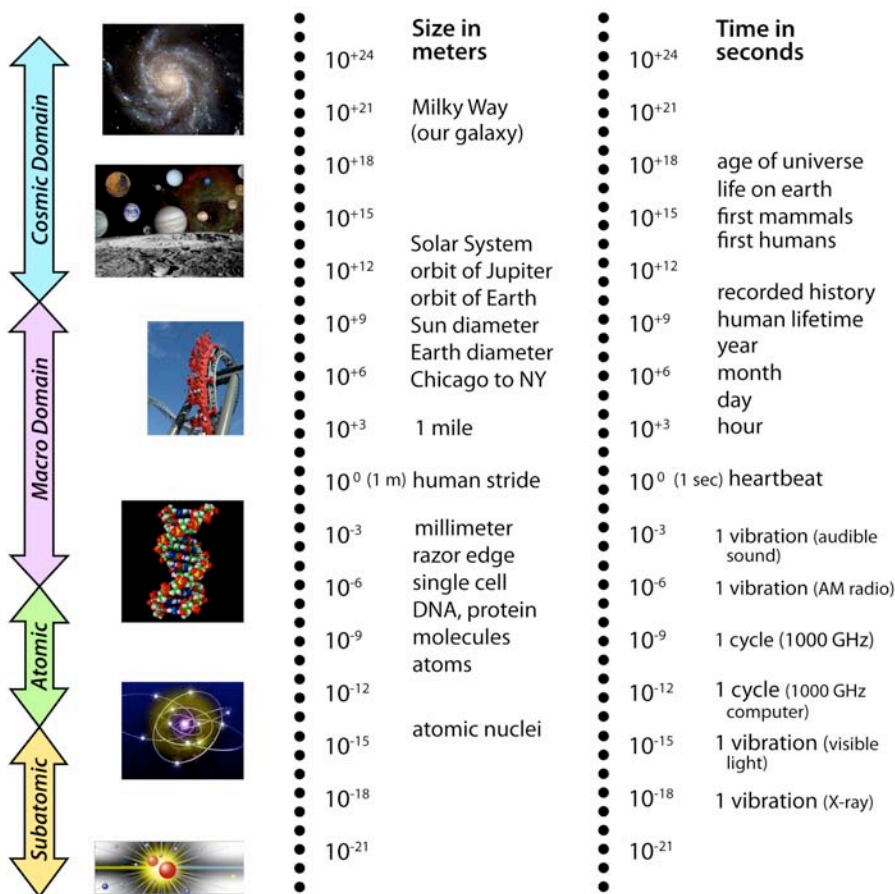

**Example of an Interaction Diagram**

Students will create many different diagrams for interactions. The example below is for cutting paper with scissors.



## OBJECTIVE 1.2

### INTERACTIONS AND PROPERTIES (Grades 5-8)

*Students understand that at the macro (human) scale, the properties of objects are qualitative or quantitative descriptions of how the object interacts with other objects or systems. Some properties do not depend on the amount of material and can be used to help identify the material.*

It may seem unnecessarily complex to define a property of an object as a qualitative or quantitative description of how the object interacts with other objects, including our senses and measurement instruments. This definition, however, helps students distinguish between physical and chemical properties and provides additional practice drawing interaction chains. Moreover, the idea is essential for an initial understanding of the small-particle model of matter (middle school) and the quantum mechanics model (high school) in Objective 1.3.

#### Table of Common Student Conceptual Difficulties

Student Difficulty. Students often believe that:	Where Addressed	
	Essential Knowledge	Learning Outcome
1. Objects have innate properties (unrelated to the way they interact with other objects).	M.1.2.1a	M.B.2 M.B.8
3. The five senses are infallible.	M.1.2.1b	M.B.1
4. Any quantity can be measured as accurately as you want.	M.1.2.4	M.B.3 M.B.4
5. You can only measure to the smallest unit shown on the measuring device.	M.1.2.4a	M.B.4
6. Gases <ol style="list-style-type: none"> <li>Gases are not matter because most are invisible.</li> <li>Gases do not have mass and volume.</li> <li>Air and oxygen are the same gas; helium and hot air are the same gas, nitrogen and oxygen have the same properties.</li> </ol>	E.6 M.1.2.3	M.B.7 M.B.9
7. Measurement of area and volume. <ol style="list-style-type: none"> <li>Only the area of rectangular shapes can be measured in square units.</li> <li>Surface area can be found only for two-dimensional objects, and is a concept used only for mathematics classes.</li> <li>You cannot measure the volume of some objects because they do not have “regular” lengths, widths, or heights.</li> </ol>	E.4 M.1.2.2a M.1.2.3	M.B.7 M.B.9
8. Measuring Volume by Displacement A heavier object displaces more volume of water (pushes aside more water) than a lighter object of the same size. Two objects with the same mass, but different sizes, will displace the same volume of water.	M.1.2.2a	M.B.4
9. Mass and volume, which both measure “amount of stuff,” are the same property.	M.1.2.5	M.B.5
10. The density of an object depends only on its volume. The density of two samples of the same substance with different volumes or shapes cannot be the same. The density of all objects with the same volume is the same.	M.1.2.5	M.B.5 M.B.6

#### Table of Content Boundaries

PHENOMENA, REPRESENTATIONS AND MODELS, AND TECHNICAL VOCABULARY
<b>Middle School</b> (Grades 5-8)
<b>OBSERVATIONS/PHENOMENA</b> (Real World) <ul style="list-style-type: none"> <li>Objects. Typical solids, such as wood, plastic, different metals blocks, cylinders, and irregular solids (several solid samples of the same substance), water, air from pump, carbon dioxide from chemical reaction; measuring tools (mass balance, rulers, thermometers, unit squares, unit cubes, graduated cylinders).</li> </ul>

PHENOMENA, REPRESENTATIONS AND MODELS, AND TECHNICAL VOCABULARY	
<b>Middle School</b> (Grades 5-8)	
<ul style="list-style-type: none"> <li>• <b>M.B.1.</b> Examples include putting hand first in warm water then in cold and comparing perceptions with thermometer readings, holding objects in hand to estimate relative masses, and so on.</li> <li>• <b>M.B.4.</b> Different methods for measuring volume: bubbling gas into inverted container filled with water; irregular solid displacing water in graduated cylinder, calculating volume of cube, rectangle cylinder; pouring liquid into graduated cylinder</li> </ul>	
<b>REPRESENTATIONS/MODELS</b>	
<ul style="list-style-type: none"> <li>• Mathematical representation of density (<math>d=m/v</math>)</li> <li>• Interaction diagram</li> </ul>	
<b>TECHNICAL VOCABULARY</b>	
<ul style="list-style-type: none"> <li>• property</li> <li>• mass</li> </ul>	<ul style="list-style-type: none"> <li>• volume</li> <li>• density</li> </ul>

**M.B.1 Examples of Interaction Chains**

A. Touching the surface of a solid object to determine if it is rough or smooth,



B. Measuring the temperature of water



**M.B.2 Evidence that Gases Have Mass**

Many students believe that gases do not have mass or volume. Demonstrating that gases have mass with balloons or plastic baggies is difficult because of large buoyancy effects. An effective method is to start with a soft basketball or soccer ball. Pump as much air as you can into the ball, and measure the mass of the ball again. The volume of the ball should not change noticeably.

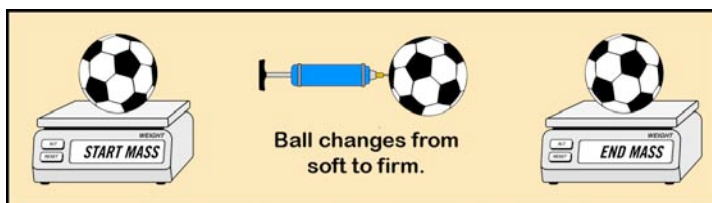

**OBJECTIVE 1.3**

**INTERACTIONS AND ATOMIC AND SUBATOMIC MODELS** (Grades 5-8 and Grades 9-12)

*Students understand that different mental models are useful at the atomic scale (small particle model of matter) and subatomic scale (quantum mechanics) for describing, explaining and predicting events, processes, and the properties of systems.*

## Grades 5-8

**Table of Common Student Conceptual Difficulties: The Small-particle Model of Matter**

Student Difficulty. Students often believe that:	Where Addressed	
	Essential Knowledge	Learning Outcome
<b>Theories and Models</b>		
1. Models as physical copies of reality, not conceptual representations.	M.1.3.2; M.1.3.5	M.B.6
2. Mental models are not useful in science. a. Mental models only help us explain things if many of the material features are also the same; if they are abstract, they don't help us.	M.1.3.4 M.1.3.6	M.B.6
3. There is no distinction between observation and theory (or mental models)	M.1.3.5 M.1.3.6	M.B.6
<b>Small Particle Model</b>		
4. There are no particles of air (air is continuous), or air is represented as cloudy, smoky, or dusty.	M.1.3.5 M.1.3.6a	M.B.4
5. Particles are embedded in stuff – like raisins in a muffin. Air is between the particles of air or a solid; water is between the particles of water.	M.1.3.5a M.1.3.6c	M.B.4
6. Particles can be seen through a microscope — they are about the size of dust particles or a cell.	M.1.3.5a	M.B.3
7. Particles in matter (particularly in solids and liquids) are stationary rather than in continual motion. Instead, they share the motion of a substance. Particles will spread out after some interaction, but then they stop moving. When a substance is moved and then left stationary, the particles will slow down and stop.	M.1.3.5d	M.B.4 M.B.5 M.B.6
8. Particles (rather than huge numbers of particles) have all or most of the same macro-properties as solids, liquids and gases—i.e., particles of solids are cold, hard and rigid; particles of liquids are warmer, larger, softer, and transparent; and particles of a gas are hot, very large and squishy, and transparent.	M.1.3.1 M.1.3.6	M.B.4 M.B.6
9. Visual representations of particles (atoms and molecules), including computer animations and simulations, are physical copies of reality – for example, oxygen atoms are red and nitrogen atoms are blue, they are the same relative size as the container in which they are shown, and move at the same speeds as shown.	M.1.3.3	M.B.4

Students of all ages show a wide range of beliefs about the nature and behavior of particles, as shown in the Table above. Despite these difficulties, there is some evidence that carefully designed instruction carried out over a long period of time may help middle-school students develop correct ideas about particles, especially in the later middle school years (grades 7-8).

**Table of Content Boundaries**

<b>PHENOMENA, REPRESENTATIONS AND MODELS, AND TECHNICAL VOCABULARY</b>
<b>Middle School (Grades 5-8)</b>
<p><b>OBSERVATIONS/PHENOMENA</b> (Real World)</p> <ul style="list-style-type: none"> <li>• <b>M.B.1.</b> Qualitative comparisons of gases, liquids and solids could include: shape, volume, density, tensile strength (how easy they are to pull apart), compressibility, and thermal expansion.</li> <li>• <b>M.B.5.</b> Almost every representation found on the web or in textbooks is poor -- not useful for the purpose of understanding the ideas in the small particle model (see example problems below). It is more difficult to find good examples.</li> <li>• <b>M.B.7.</b> The physical properties include, but are not limited to: why we can pour liquids, but not solids; why it is difficult to pull most solids apart (tensile strength); why gases are far more compressible than liquids and solids; why the density of gases is so much smaller than the density of liquids and solids; why air can push on objects from all directions, or why we can blow up a balloon.</li> </ul>
<p><b>REPRESENTATIONS/MODELS</b></p> <ul style="list-style-type: none"> <li>• Small-particle model of gases, liquids, and solids (mental model).</li> <li>• Visual representations of particles (atoms and molecules). Animations and simulations of the motion and spacing of particles of a gas, liquid, and solid.</li> <li>• Verbal descriptions.</li> </ul>



## PHENOMENA, REPRESENTATIONS AND MODELS, AND TECHNICAL VOCABULARY

Middle School (Grades 5-8)

## TECHNICAL VOCABULARY

- theory
- mental model

Underlined words and phrases are defined in the Glossary.

**M.B.1 and M.B.7. Visual Representations at Atomic Scale of Thermal Expansion and Contraction**

Students have a difficulty visualizing thermal expansion and contraction at the atomic scale. Visual representations, animations, and simulations are helpful.

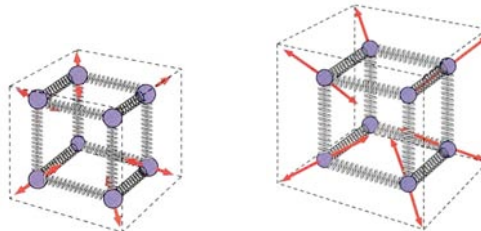
**M.B.4 -- Example Problems**

1. The purpose of the picture at right is to help younger students understand two small-particle model ideas: (a) Substances are made up of a huge number of very tiny particles (atoms or molecules). The particles of a (pure) substance are too small to see with a visible-light microscope; and (b) There is nothing between the particles of a substance (the space is empty of stuff). Is this picture good or poor for this purpose? Explain your reasoning. If it is poor, revise the representation.<sup>1</sup>

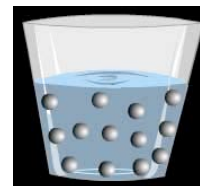

*Answer.* This picture is poor because (a) the particles are shown floating in the liquid, rather than as consisting of particles with nothing between the particles, and (2) the particles are shown to be about the size of marbles, rather than tiny particles too small to see even through a visible-light microscope.

2. The purpose of the diagram below is to show how much space there is between the particles of a solid, liquid, and gas, on the average. Is this diagram good or poor for this purpose? Explain. If it is poor, revise the representation.<sup>2</sup>

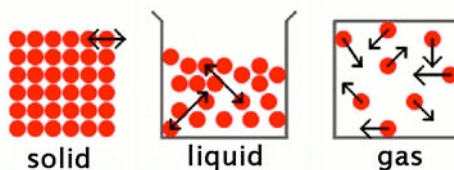

*Answer:* This is a poor diagram because liquid particles should only be a tiny fraction further apart than the particles in the solid, and the particles of a gas should be about 10 times farther apart than in solids and liquids. In addition, all representations should have a black background (like the empty space between the planets) because there is nothing to reflect light.

Visual representations of particles should use magic eyeglasses or a magical microscope, like the “Ultrascope” representations below (Goldberg, Bendall, Heller, and Poel, 2006).

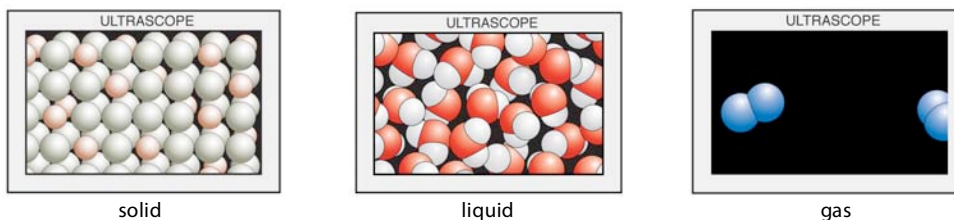

<sup>1</sup> Image from <http://goalfinder.com/product.asp?productid=71>

<sup>2</sup> Image from <http://www.explainthatstuff.com/statesofmatter.html>



## Grades 9-12

The approach taken to quantum mechanics is similar to that of Richard Feynman in his book QED: The Strange Theory of Light and Matter (1985). The approach is modern and attempts to avoid many student misconceptions by excluding the historical arguments of wave-particle duality, the uncertainty principle, and de Broglie's wavelength.

**Table of Common Student Conceptual Difficulties: The Quantum Mechanics Model**

Student Difficulty. Students often believe that:	Where Addressed	
	Essential Knowledge	Learning Outcome
1. Atomic Structure a. Electrons orbit the nucleus. Atoms have electrons circling them like planets around a star. b. Electrons are physically larger than protons c. Electrons and protons are the only fundamental particles.	H.1.3.1 H.1.3.5c	H.B.1
2. The wave function describes the trajectory of an electron.	H.1.3.5b	----
3. The position of a particle always can be exactly known.	H.1.3.6	H.B.5
4. Wave-particle duality. a. Light <i>is</i> one or the other--a particle or a wave. b. Light and electrons are <i>innately</i> sometimes a particle or sometimes a wave, and switch back and forth as they move. c. The electron "waves" as it moves. d. A photon is a particle with a wave inside.	H.1.3.3 H.1.3.7	H.B.3 H.B.6
5. Electron "clouds" of atoms a. Electron clouds of atoms are pictures of their "orbits". b. The electron cloud is like a rain cloud, with electrons suspended in it like droplets of water. c. The cloud contains the electrons but is made of something else.	H.1.3.5c	H.B.5
6. Spectral lines are the same as the energy levels of electrons in the atoms.	H.1.3.2	H.B.2

Student misconceptions about the "orbitals" of the electrons in atoms, the meaning of electron "clouds," and emission and absorption spectra depend on whether students take chemistry before physics or vice versa

**Table of Content Boundaries**

<b>PHENOMENA, REPRESENTATIONS AND MODELS, AND TECHNICAL VOCABULARY</b>
<b>High School (Grades 9-12)</b>
<p><b>OBSERVATIONS/PHENOMENA</b> (Real World)</p> <ul style="list-style-type: none"> <li>• <b>H.B.2.</b> If available, gas discharge tubes or flame tests for different elements, and diffraction gratings (or simulations); pictures of emission and absorption spectra of elements and some stars, including our Sun.</li> <li>• <b>H.B.3.</b> Evidence for wave-like and particle-like behavior of photons and electrons is qualitative. See additional comment below.</li> <li>• <b>H.B.4.</b> See comments below.</li> </ul>
<p><b>REPRESENTATIONS/MODELS</b></p> <ul style="list-style-type: none"> <li>• Quantum model of the interaction of subatomic particles with macroscopic materials.</li> <li>• Baseball analogy of the path of subatomic particles from one location to another.</li> <li>• Visual representations, animations and/or simulations of two-slit interference, electron diffraction.</li> <li>• Visual representation of energy levels of an electron in an atom, with emission and absorption transitions shown.</li> <li>• Analogue models of energy levels (e.g., steps on ladder), emission, and absorption of light at definite energy values (e.g., jumping up and down different numbers of steps on step)</li> </ul>
<p><b>TECHNICAL VOCABULARY</b></p> <ul style="list-style-type: none"> <li>• <u>two-slit interference</u></li> <li>• diffraction</li> </ul>

**PHENOMENA, REPRESENTATIONS AND MODELS, AND TECHNICAL VOCABULARY**

**High School (Grades 9-12)**

- energy levels of electrons (in atoms)
- emission spectra and absorption spectra

Underlined words and phrases are defined in the Glossary.

***H.B.3. and H.1.3.2 – Experimental Evidence of the Wave and Particle Models of Subatomic Interactions***

An understanding of the complexities of the four classes of experiments is not necessary for this learning outcome, as illustrated below

1. Experiments with light interacting with single or double slits that result in a diffraction pattern or two-source interference pattern, which are characteristic of the interaction of mechanical waves with slits.

Students should develop a good mental visual image of two-slit interference patterns of light, through demonstrations, photographs, and animations and simulations (see Objective 4.4).

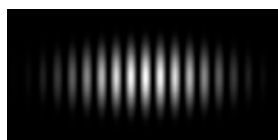
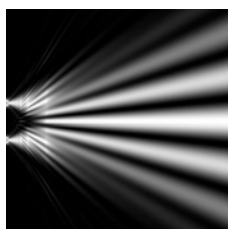

View of screen

2. Experiments with light interacting with metals (photoelectric effect), which result in data patterns characteristic of the interaction of objects (called photons) with discrete energies interacting with other objects (electrons of the metal atoms).

According to a wave model, the more intense the incident light the greater the energy with which the electrons should be ejected from the metal. That is, the average energy carried by an ejected electron should increase with the intensity of the incident light. The frequency (energy) of the light should not make a difference. The results of the photoelectric experiment showed, however, that:

- (a) Red light will not cause the ejection of electrons, no matter what the intensity.
- (b) Violet light will eject electrons, but their maximum kinetic energies are less than those for light of higher frequencies (higher energy).
- (c) As the intensity of the incident light is increased, more electrons are emitted, but their maximum kinetic energy does not increase.

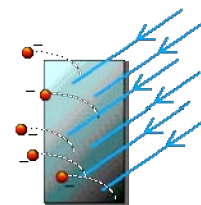

In 1905, Einstein proposed that the incident light consists of individual photons that interacted with the electrons in the metal like discrete particles, rather than as continuous waves. For a given frequency or 'color' of the incident radiation, each photon carried the energy  $E = hf$ , where  $h$  is Planck's constant and  $f$  is the frequency. Increasing the intensity of the light corresponds to increasing the number of incident photons per unit time, while the energy of each photon remained the same.

3. Experiments with electrons interacting with crystals (whose atomic structure acts like slits) resulting in diffraction or interference patterns, which are characteristic of the interaction of mechanical waves with slits.

Students should develop good mental images of electron and photon (e.g., x-ray) diffraction from crystals.

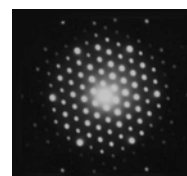



4. Experiments with high-energy particles interacting with materials that result in data patterns characteristic of the interaction of discrete objects.

A bubble chamber consists of a vessel filled with a liquid heated nearly to the boiling point. When the pressure on the fluid is suddenly dropped, the fluid becomes overheated.

High energy cosmic rays from the sun passing through the bubble chamber leave a visible string of bubbles left by the particles as they fly through a liquid.

#### **H.B.4 -- Partial Explanation**

When a photon or electron beam is directed towards two slits in a barrier, a two-slit interference pattern is seen.

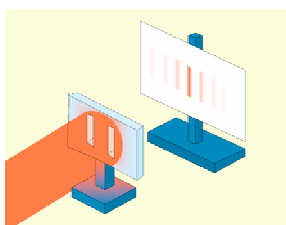

When electrons (or photons) are allowed to go through the slits one at a time and produce a spot on a special screen, the interference pattern builds up very slowly, as shown in the photographs at right. The final pattern is exactly the same as predicted mathematically by using quantum mechanics rules to add up the probabilities of all possible paths of the electrons through the slits to the screen. Quantum mechanics does not tell us which slit the photons go through.

"It is tempting to ask the question: Which way did the photon really go?" This is a question that many people have given some serious thought, including Albert Einstein, Richard Feynman, and Werner Heisenberg. They came up with thought experiments that proposed to measure the "which-way" information of a particle's path on its way to the screen. They came to a rather perplexing conclusion, however, namely that it is not possible to observe the "which-way" information and the interference pattern simultaneously. One can set up a measurement to 'watch' which slit a photon goes through. It can be determined that the photon went through one slit and not the other. However, once this is kind of measurement is set up, the photons will no longer collectively produce a nice pattern of bright and dark spots. Instead they will strike the screen in one big bright spot, as if there were only one slit instead of two." (Luis Orozco and graduate students, A Double-Slit Quantum Eraser Experiment, <http://grad.physics.sunysb.edu/~amarch/>) See also [http://en.wikipedia.org/wiki/Double-slit\\_experiment](http://en.wikipedia.org/wiki/Double-slit_experiment).

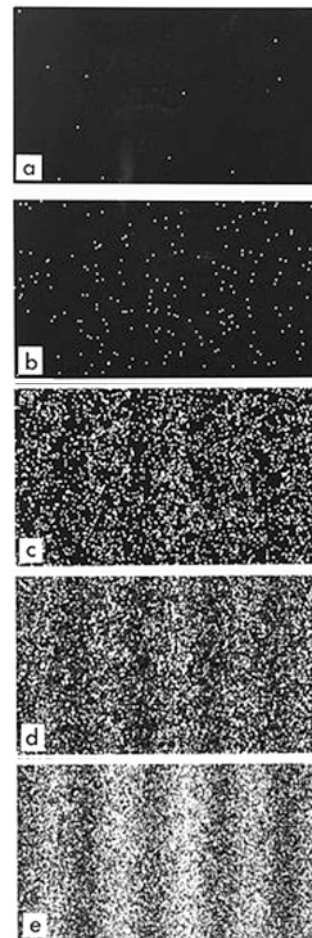

Electron buildup over time when single electrons are fired at a double slit.

### **OBJECTIVE 1.4**

#### **INTERACTIONS AND OBJECTS MOVING VERY FAST (Grades 9-12)**

*Students understand that the Newtonian ideas about absolute space and time are incorrect, as Einstein demonstrated with his special theory of relativity.*

#### **Table of Common Student Conceptual Difficulties**

Student Difficulty. Students often believe that:	Where Addressed	
	Essential Knowledge	Learning Outcome
1. Postulates cannot be used to develop a theory.	H.1.4.3	H.B.1
2. Length and time changes are just apparent.	H.1.4.4a H.1.4.4b	H.B.5
3. Time is absolute	H.1.4.3a	H.B.2 H.B.4 H.B.5
4. Length and time only change for one observer.	H.1.4.4a H.1.4.4b	H.B.3 H.B.4 H.B.5
5. Time dilation refers to 2 clocks in 2 different frames.	H.1.4.4a	H.B.4 H.B.5
6. Time dilation and length contractions have not been proven in experiments.	H.1.4.3	H.B.1
7. There exists a preferred frame of reference in the universe.	H.1.4.3b	H.B.4 H.B.5
8. Velocities for light are additive like for particles.	H.1.4.4d	H.B.4 H.B.5

**Table of Content Boundaries**

<b>PHENOMENA, REPRESENTATIONS AND MODELS, AND TECHNICAL VOCABULARY</b>
<b>High School (Grades 9-12)</b>
<p><b>OBSERVATIONS/PHENOMENA</b> (Real World)</p> <ul style="list-style-type: none"> <li>• <b>H.B.1.</b> Limited to simple descriptions of a few experiments. See additional comments below.</li> <li>• <b>H.B.4.</b> See some example questions for this learning outcome in the comments below.</li> </ul>
<p><b>REPRESENTATIONS/MODELS</b></p> <ul style="list-style-type: none"> <li>• Visual representations of time dilation and length contraction,</li> <li>• Simulations of time dilation, length contraction, 4-dimensional space-time events (see, for example, <a href="http://nobelprize.org/educational_games/physics/relativity/index.html">http://nobelprize.org/educational_games/physics/relativity/index.html</a>)</li> </ul>
<p><b>TECHNICAL VOCABULARY</b></p> <ul style="list-style-type: none"> <li>• inertial frame of reference (see comments below)</li> <li>• Michelson-Morley experiment</li> <li>• time dilation</li> <li>• length contraction</li> </ul>

Underlined words and phrases are defined in the Glossary.

**Inertial Frame of Reference**

From Einstein’s first postulate, it follows that there is no coordinate system that is in absolute rest. All motion with constant speed is relative and any coordinate system moving with constant speed (relative to the "fixed stars") is called *an inertial coordinate system (or inertial frame of reference)*. In the at right, two inertial frames A and B are moving with constant speed  $v$  relative to each other. An observer at rest in A will say that objects at rest in B are moving with respect to A. On the other hand, an observer at rest in B will say that it is the objects at rest in A that are moving with respect to B. Motion is relative. [See also

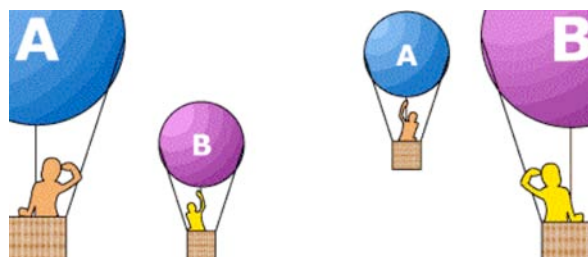

[http://nobelprize.org/educational\\_games/physics/relativity/postulates-2.html](http://nobelprize.org/educational_games/physics/relativity/postulates-2.html).]

### Experimental Evidence for H.B. 1.

There are hundreds of experiments about the postulates and consequences of Einstein's theory of relativity. Only a few are considered here. [See [http://en.wikipedia.org/wiki/Michelson-Morley\\_experiment#Einstein\\_and\\_special\\_relativity](http://en.wikipedia.org/wiki/Michelson-Morley_experiment#Einstein_and_special_relativity), and <http://www.desy.de/user/projects/Physics/Relativity/SR/experiments.html>.]

#### 1. Michelson-Morley Experiment – The Speed of Light is Constant in a Vacuum

In the late 1800s it was presumed that if light is a wave, then it must have a medium in which to travel. All the other waves require a medium. Since no medium was apparent between the Earth and the sun, it was hypothesized that this medium was transparent and therefore not readily observable - it was called the "ether." The popular belief was that this ether was stationary and filled all of space. This involved the assumption that there was an absolute reference frame in the universe, and that all the movement of planets and stars was through this ether.

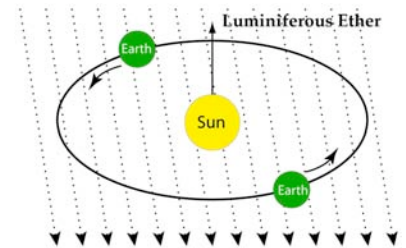

With a new instrument called an interferometer, Albert A. Michelson and Edward W. Morley (1887) arranged one set of light beams to travel parallel to the direction of the Earth's motion through space, another set to travel crosswise to the motion. The experimental result was that the speed of the Earth through the ether was zero. This experiment, like most important new science, was done at the very limit of available techniques. The results were long in dispute. It was only after the invention of lasers that it became easy to show beyond reasonable doubt that the speed of light in a vacuum is invariable -- independent of the speed of the observer. [See also <http://hyperphysics.phy-astr.gsu.edu/>.]

#### 2. Velocities Do Not Depend on the Velocity of a Moving Source of Light

There are "obvious" optical effects that *are not seen* in astronomical photographs that would be expected if the speed of light depended on the velocity of a moving source of light. One example is the observation of binary stars in which the light from the two stars can be measured with an interferometer. If the speed of light depended on the source velocity, the light from the stars should cause fringe shifting due to the velocity of the stars being added to the speed of the light, but no such effect can be seen. A supernova explosion sends debris out in all directions with speeds of 10,000 km/s or more. If the speed of light depended on the source velocity, its arrival at Earth would be spread out in time due to the spread of source velocities. Such a time spread is not observed.

#### 3. Time Dilation

High-energy particle accelerators and detectors would not exist without special relativity. For example, the path of particles which have lifetimes less than  $10^{-6}$  seconds are seen in bubble chamber photographs of cosmic rays. Without time dilation, the paths would not be observable. Similarly, other detectors of high-energy particles could not be built without time dilation.

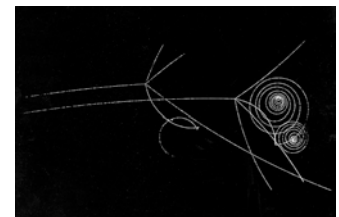

#### 4. Length Contraction

At this time there are no *direct* tests of length contraction, because measuring the length of a moving object to the precision required has not been feasible.

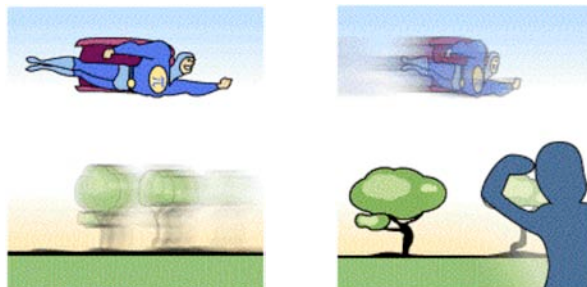

There is however, much indirect evidence. Kennedy and Thorndike (1932) modified the original Michelson-Morley experiment by making the path lengths of the split beam unequal, with one arm being very short. The null results were presented as evidence for both length contraction and time dilation. Edward M. Purcell (1984) demonstrated that the large magnetic force from a current carrying wire on moving charges in a second wire is due to the different length contractions of the positive and negative charges in the wire (the former are fixed relative to the wire, while the latter are mobile with drift velocities of a few mm per second).

#### Example Question and Answer for H.B.4.

There are no resources for these questions. One strategy for creating questions is to start with a misconceptions in the *Table of Common Student Conceptual Difficulties*. For example, the question below is based on Misconception #7. Another strategy is to save students' explanations, modify slightly, and use the following year.

**Question.** Evaluate the following explanation of time dilation in special relativity, based on the criteria: (a) the explanation is based on evidence; (b) the explanation is based on the correct special relativity idea(s); (c) the explanation is complete (no important special relativity ideas are missing from the explanation); and (d) the explanation is logical.

*The light clock on the moving train (velocity  $v$ ) measures the time interval  $\Delta t$  for the light to travel a distance  $2d$ . The stationary observer thinks the time interval is slow because the light really travelled a longer distance during the time  $\Delta t$ , as shown in the diagram below. Similarly, the observer on the moving train thinks the stationary observer's clock is running slow because he is moving backwards with a speed  $v$ . But both observers are moving relative to the rotating Earth, which is moving relative to the solar system, which in turn is moving relative to our galaxy, and so on.*

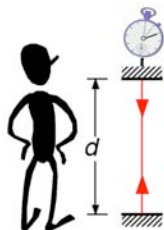

Observer on moving train watching a clock.

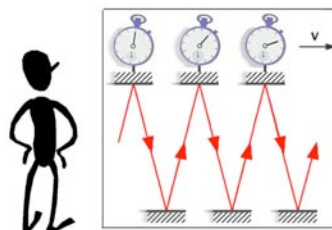

Stationary observer watching a clock on the moving train.

*Therefore time dilation is each observer thinking the other's clock is running slow because of his or her relative motion. However, from a coordinate system at the center of the universe, there is no time dilation. Time is absolute in this reference frame.*

**Answer.** *This is a poor explanation because it does not include the correct postulate of Einstein's theory of special relativity, or the evidence for time dilation – that even biological clocks run slow for uniformly moving reference frames.*



## INSTRUCTIONAL GUIDANCE FOR STANDARD 2. CONSERVATION PRINCIPLES

*The interaction of one object with another object is governed by a few conservation principles. These principles are considered fundamental because they apply to interactions at all time and size scales and cannot be derived from other theories.*

### OBJECTIVE 2.1

#### CONSERVATION OF MASS, ENERGY, AND CHARGE (Grades 5-8 and Grades 9-12)

*Students understand that at the macro (human) scale, mass and energy are conserved separately, within measurement errors, for all types of interactions and defined systems (open or closed). Charge is always conserved at all scales.*

Students are introduced to the conservation principle, sometimes called the continuity equation: the total change in a quantity ( $Q$ ) within a system ( $\Delta Q$ ) is equal to the total transfer of the quantity into or out of the system ( $Q_{in} - Q_{out}$ ). The principle is applied to the conservation of mass in grades 5-8, and the conservation of energy at the macro scale in grades 9-12.

### Grades 5 – 8

#### Learning Progression for the Conservations Principle

At first glance, the Essential Knowledge statements for the conservation principle (M.2.1.2) and the conservation of mass (M.2.1.4) appear too detailed and complex for middle school – it seems that the principle would make the conservation of mass more difficult for students to learn rather than lead to an improved understanding of conservation. This view, however, is contradicted by accepted principles of learning and research in mathematics education. To develop a progression of learning, *students' previous knowledge should be identified and built upon in a cumulative manner.* Children in grades 3 - 5 have very few prior experiences solving problems for closed systems in their everyday lives. They do, however, have a great deal of prior experience with gaining and losing objects and using the conservation principle. For example, consider the following problem.

*You started with 10 quarters. You went to the grocery store and spent 5 quarters. When you got back home, you had 3 quarters.*

Children have no difficulty figuring out that they must have lost two quarters somewhere on the way to or from the store or while they were in the store. Without the name, they intuitively use the conservation principle.

In grades 5-7, students can begin relating a systems analysis to the mathematical sentence for the conservation principle in everyday situations. For example, consider the following problem:

*Imagine that you started the day with a large bowl of 16 strawberries. Before you left for school you ate 2 strawberries. When you got home, there were 12 strawberries in the bowl. How many strawberries were added or removed from the bowl? The system is the bowl of strawberries and the time interval from the start of the day to when you got home.*

Students should be able to solve this problem using the mathematical sentence:

change in number of strawberries = total number of strawberries removed or added

The learning progression for the conservation of mass principle within middle school proceeds from the conservation of concrete objects to exploring the conservation of continuous quantities like mass, volume and surface area for different interactions. By the end of middle school, students should know that at the macro (human) scale only mass is conserved, within measurement errors, for all physical and chemical interactions and for all defined systems, open or closed.

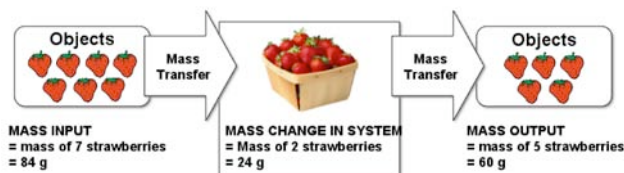

**Table of Common Student Conceptual Difficulties with Mass and Energy**

Student Difficulty. <sup>+</sup> Students often believe that:	Where Addressed	
	Essential Knowledge	Learning Outcome
1. Models are physical copies of reality, not conceptual representations. They are not useful in science.	M.2.1.1	M.B.4 H.B.1
<b>Conservation of Mass</b>		
2. The conservation of mass is not very useful because all quantities are conserved.	M.2.1.4	M.B3 M.B.5
3. Mass is only conserved in a closed system. When the system is open, mass can disappear (e.g., evaporation).	M.2.1.2 M.2.1.4	M.B3 M.B.7
4. Mass increases or decreases when energy is transferred into or out of the defined system (without a transfer of materials). a. When a solid object is heated, its mass increases; when an object is cooled, its mass decreases. b. When heat, light or sound are produced during an interaction, the mass of the system decreases.	M.2.1.5	M.B.6
5. Mass increases or decreases when the shape, density, or phase of an object changes during physical and chemical interactions. a. When a flexible solid object is spread out, the mass of the object decreases (e.g., spreading out the strands of a piece of steel wool, changing the shape of a piece of clay from a ball to a flat pancake). b. When a solid is formed during a chemical reaction in a closed system, the mass of the closed system increases; when a gas is formed, the mass decreases. c. When an object is cooled and changes phase, the mass of the object increases; when an object is heated and changes phase, the mass of the object decreases.	M.2.1.4	M.B.3 M.B.7 M.B.8
<b>Conservation of Energy</b>		
6. All energies are the same. a. Energies are always the same (electrical, kinetic, thermal, etc) for all defined systems and time intervals. [Because one form of energy can always be transformed into another form of energy.] b. There are no energy terms for transfer (energy in transit from one location to another) that are different from the energies that objects can have.	H.2.1.1 H.2.1.2 H.2.1.4	H.B.3 H.B.4 H.B.5
7. Energy is only conserved in a closed system. When the system is open, energy can sometimes disappear. [Things, like light bulbs, “use up” energy.]	H.2.1.1	H.B.2
8. There is nothing special about the conservation of energy – all quantities are conserved in a closed system.	M.2.1.4	M.B.3
9. The conservation of energy is useless; it does not help think about or solve problems (qualitatively or quantitatively).	H.2.1.1	H.B2
10. The conservation of mass, charge, and energy are not fundamental principles of science.	H.2.1.6	H.B.7

<sup>+</sup> For conceptual difficulties with specific types of energy, see Objective 4.1 through Objective 4.5

**Table of Content Boundaries**

<b>PHENOMENA, REPRESENTATIONS AND MODELS, AND TECHNICAL VOCABULARY</b>
<b>Middle School (Grades 5-8)</b>
<b>OBSERVATIONS/PHENOMENA (Real World)</b>
<ul style="list-style-type: none"> <li>• <b>M.B.3.</b> Students investigate interactions that result in: <ul style="list-style-type: none"> <li>- Changes in the number of identical objects; changes in surface area, changes in perimeter;</li> <li>- Changes in shape (e.g., spreading out strands of steel wool, changing the shape of a piece of clay from a sphere to a flat pancake);</li> <li>- Changes in temperature (heating a piece of metal in hot water, heating a liquid in a closed container – no phase change);</li> <li>- Changes in state (e.g., boiling water in open and closed containers, freezing water);</li> </ul> </li> </ul>



**PHENOMENA, REPRESENTATIONS AND MODELS, AND TECHNICAL VOCABULARY****Middle School (Grades 5-8)**

- Chemical changes (e.g., forming a solid when two liquids are mixed, forming a gas during an chemical reaction in a closed and open container, burning a candle in a closed and open container);
- Changes in volume (e.g., mixing alcohol and water, dissolving rock candy or rock salt in water);
- Lighting a bulb or running a motor with a battery until the battery is “dead.”

Students must investigate enough changes to be convinced that, for example, while surface area and volume are sometimes conserved and sometimes not conserved, mass is conserved, within measurement errors, through all of the interactions and changes (M.2.1.4). They also need evidence that the transfer of energy into or out of an object/system (without mass transfer) does not change the mass of the system within the measurement errors (e.g., heating a metal cube in water, placing a circuit on a balance)(M.2.1.5).

- **M.B.7.** Examples should include mass transferred into the system, mass transferred out of the system, different values of mass transferred into and out of the system, the rate of mass transfer into the system the same as the rate of mass transfer out of the system (dynamic equilibrium), and of course, closed systems.

**REPRESENTATIONS/MODELS**

- Analogue models of conservation (e.g., simple a coin/money bank, number of strawberries in a bowl, grinding coffee, and so on)
- Mathematical sentences for conservation and conservation of mass

**TECHNICAL VOCABULARY**

- conservation principle
- conservation of mass principle

Underlined words and phrases are defined in the Glossary.

**M.B.3 Suggestion for Measuring Mass Changes**

Students will not be convinced by their measurements that mass is conserved, partly because their measurement procedures are usually poor. Have each member of a class measure the mass of the same object (once or several times over a few days) and determine a “class” measurement error by taking an average and finding the standard deviation (students do not need to understand standard deviations to recognize that there is a procedure for determining the error). In all mass investigations, have the student groups calculate the mass change within the system (closed system) or the mass change within the system minus or plus the total mass transfer into or out of the system (open system). All calculations should be close to zero. Take the class average and add the class measurement error. The average is always very close to zero and well within measurement errors. School averages for several classes can also be determined, and the average is even closer to zero.

**M.B.4 Analogue Models**

There are many analogue models for the conservation of mass. The model that can be extended in complexity in grades 9-12 is the banking model shown below.

**Grades 9 – 12**

The approach taken to the conservation of energy equation is similar to that of John Jewett Jr. (2008d) in his article *Energy and the confused student: A Global Approach to Energy*:

"It is my position in this article that there is only *one* fundamental energy equation and that all other energy equations are special cases. The fundamental equation is called the *conservation of energy equation* or the *continuity equation for energy*, both of which can be abbreviated as CEE:

$$\Delta E_{\text{system}} = \sum T,$$

where  $T$  represents the amount of energy transferred ( $T$  for *transfer*) across the boundary of the identified system by a given mechanism. The general conceptual basis of the equation is this: the only way the total energy  $E_{\text{system}}$  of a system can change is if energy crosses the system boundary by one or more mechanisms described by  $T$ . The mathematical basis is this: the total change in energy of the system during some time interval is exactly equal to the net amount of energy crossing the system boundary. The summation sign indicates that energy may cross the boundary by several methods.

... On the right side of the CEE is the total amount of energy that crosses the boundary of the system, expressed as the sum of the energy transferred by six common processes:

$W$ : work done on the system by external forces whose points of application move through displacements

$Q$ : energy transferred across the boundary of the system by *heat* due to a temperature difference between the system and its environment

$T_{MT}$ : energy transferred across the boundary of the system by *matter transfer* (such as transferring a fuel into a tank)

$T_{MW}$ : energy transferred across the boundary of a system by *mechanical waves* such as sound waves or seismic waves

$T_{ER}$ : energy transferred across the boundary of a system by *electromagnetic radiation* such as light or microwaves

$T_{ET}$ : energy transferred across the boundary of a system by *electrical transmission* from a battery or other electrical source

It is instructive to spend time discussing this equation and its individual terms when energy is first introduced. Students are familiar enough from everyday life with the six types of energy transfer in the equation that they can quickly understand the nature of energy transfers and the meaning of the equation. In my experience, ... after gaining familiarity and experience with the approach, they [students] often begin with the [CEE equation] and build the appropriate equation by listing just those terms that are needed to analyze the situation." [pages 210 – 211]

## Grades 9 - 12

### Table of Content Boundaries

PHENOMENA, REPRESENTATIONS AND MODELS, AND TECHNICAL VOCABULARY							
High School (Grades 9-12)							
<b>OBSERVATIONS/PHENOMENA</b> (Real World)							
<ul style="list-style-type: none"> <li>Objects and Events. Similar to those in Standards 3 and 4, and Objective 5.2, but situations involve multiple interactions.</li> <li><b>H.B.2. <u>Methods of energy storage</u></b> within a system include (See Objectives 4.1 through 4.5 and Objective 5.2):               <table border="0"> <tr> <td>- kinetic energy</td> <td>- gravitational potential energy</td> </tr> <tr> <td>- thermal energy,</td> <td>- electrical potential energy</td> </tr> <tr> <td>- elastic energy (e.g., spring),</td> <td>- magnetic potential energy</td> </tr> </table> </li> </ul>		- kinetic energy	- gravitational potential energy	- thermal energy,	- electrical potential energy	- elastic energy (e.g., spring),	- magnetic potential energy
- kinetic energy	- gravitational potential energy						
- thermal energy,	- electrical potential energy						
- elastic energy (e.g., spring),	- magnetic potential energy						
<u>Methods of energy transfer</u> include (See Objectives 4.1 through 4.5):							
- mechanical energy transfer (work),	- electrical energy transfer in circuits, and						
- mechanical wave energy transfer,	- radiant energy transfer (EM).						
- thermal energy transfer (heat),							
<ul style="list-style-type: none"> <li><b>H.B.3.</b> One example, among many, is shown below.</li> </ul>							
<b>REPRESENTATIONS/MODELS</b>							
<ul style="list-style-type: none"> <li>More complex <u>analogue models</u> can be considered for the conservation of energy: for example, a banking account that includes savings, investments with dividends, interest charges, etc. See comments below</li> <li>Symbol <math>\Delta</math> to represent "change in."</li> <li>Mathematical model of energy conservation (<math>\Delta E_{\text{system}} = E_{\text{in}} - E_{\text{out}}</math>)</li> <li><u>Energy diagram</u> (see comment below)</li> </ul>							

Underlined words and phrases are defined in the Glossary.

### H.B.1 Analogue Models

There are many analogue models for the conservation of energy principle. One model that builds on an earlier grade 5-8 banking model is the Financial Asset Model of Energy by Patricia Westphal (2010). In this model, types of banking accounts within system are analogous to different methods of storing energy; banking transfer processes are analogous to transfers of energy into or out of the system.

#### Types of banking accounts with system:

- Checking accounts
- Savings accounts
- IRAs
- Stocks and bonds

#### Transfer processes that may arise:

- Working
- Theft
- The lottery
- Interest
- Insurance
- Taxes
- Inheritance
- Many others

### H.B.3 Example Problem

**Event:** A battery is connected to a switch and bulb.

- (a) System of interest is the complete circuit; time interval is the tiny (unnoticeable) time after the switch is closed and while the bulb's brightness is increasing. The energy change within the system is a decrease in the chemical energy of the battery and an increase in the thermal energy of the bulb filament (because the temperature of the bulb filament is increasing). There is a transfer of radiant energy (mostly visible light and infrared) out of the system. [Note: A heat conduction energy transfer is much slower than a radiant energy transfer, so for this tiny time interval, it can be ignored.]
- (b) System of interest is the bulb filament; time interval is the tiny (unnoticeable) time after the switch is closed and while the bulb's brightness is increasing. The energy change within the system is an increase in the thermal energy of the bulb filament (because the temperature of the bulb filament is increasing). There is a transfer of electrical energy into the bulb filament (from the battery) and a radiant energy transfer out of the system.
- (c) System of interest is the bulb filament; time interval is a few minutes while the bulb brightness is not changing. There is a transfer of electrical energy into the system and a transfer of radiant energy out of the system. There is no change in energy of the filament. (Changes in the internal energy of the bulb filament are ignored at the high school level.)

### Energy Diagrams

There are, of course, many different ways of drawing energy diagrams. The most extensive discussion is by Greg Swackhamer in the paper *Cognitive Resources for Understanding Energy* (2010). More examples are in Instructional Guidance for Standard 4.

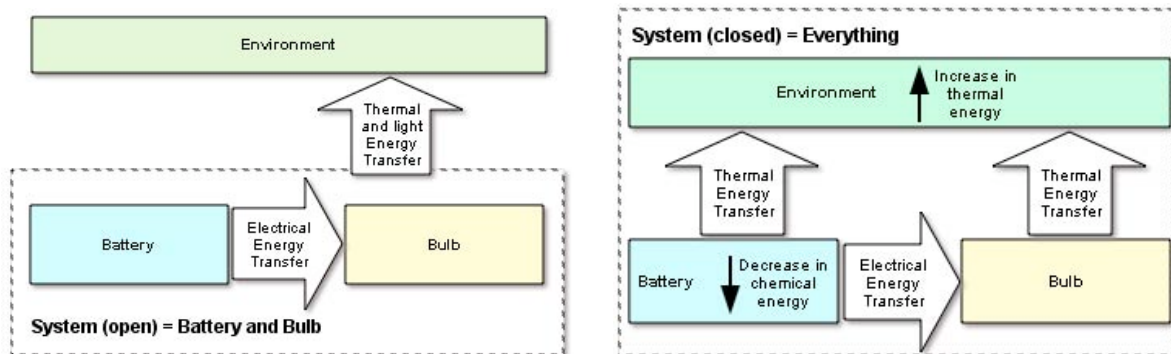

Some diagrams show only the transfers of energy

Some diagrams also show the changes of stored energy

Systems involving potential energy show the transfer of energy into or out of the field (see Objective 5.2), as shown below.

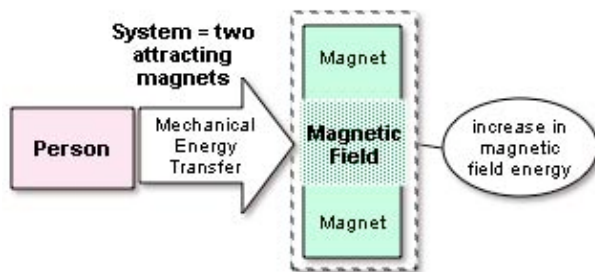

Below is a slightly different type of energy diagram (Goldberg, Bendall, Heller, and Poel, 2006).

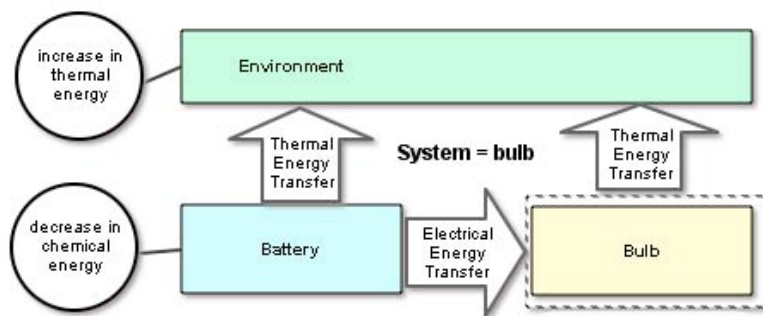

## OBJECTIVE 2.2 CONSERVATION OF LINEAR MOMENTUM (Grades 9-12)

*Students understand that linear momentum is conserved at all size and time scales, and for all types of interactions and defined systems (open or closed).*

### Table of Common Student Conceptual Difficulties

Student Difficulty. Students often believe that:	Where Addressed	
	Essential Knowledge	Learning Outcome
1. Momentum a. Momentum is not a vector. b. Momentum is the same as force.	H.2.2.1 H.2.2.3	H.B.2 H.B.3
2. Impulse a. The relationship between momentum change and impulse applies <i>only</i> to collisions. b. Moving masses in the absence of gravity do not have momentum.	H.2.2.3	H.B.1 H.B.4 H.B.5
3. The conservation of linear momentum applies only to closed systems; in open systems momentum can disappear.	H.2.2.2	H.B.1 H.B.6
4. The conservation of linear momentum applies only to collision (and explosion) interactions.	H.2.2.2	H.B.1
5. The conservation of linear momentum is useless; it does not help us think about or solve problems (qualitative or quantitative).	H.2.2.4	H.B.4, H.B.5 H.B.7 thru H.B.11
6. Newton's Laws are the most important laws (or the only fundamental laws) in physics – everything else can be derived from these Laws.	H.2.2.6	H.B.12

## Table of Content Boundaries

PHENOMENA, REPRESENTATIONS AND MODELS, AND TECHNICAL VOCABULARY	
High School (Grades 9-12)	
<b>OBSERVATIONS/PHENOMENA</b> (Real World)	
<ul style="list-style-type: none"> <li>Events. Elastic collisions include many sports examples: bat hits baseball, golf club hits ball off tee, racquet hits tennis balls, balls bounce off walls. Lab equipment includes low friction carts with bumpers.</li> <li><b>H.B.1.</b> Examples of interactions in which a constant force is applied to an object for a longer amount of time than in collisions include, but are not limited to: a small object falling toward the ground; a small object moving upwards by being lifted at a constant speed or by being thrown upwards; the pulling or pushing of a low-friction object across a long, straight path, as with frictionless carts in the lab, or word problems where a frictionless surface can be assumed.</li> <li><b>H.B.4.</b> Processes that are designed to reduce injury or to maximize a force include, but are not limited to: a seat belt increasing the time interval over which the change in linear momentum occurs to decrease force; packing materials to protect fragile items; pulling back hands when catching a fragile item; bending at the knees when landing from a jump; and a Karate chop occurring over a short time to maximize force</li> <li><b>H.B.7.</b> Traffic accidents can be on land, in the air, or in space.</li> </ul>	
<b>REPRESENTATIONS/MODELS</b>	
<ul style="list-style-type: none"> <li><math>\Delta</math> and <math>\Sigma</math> symbols in mathematical relationships.</li> <li>Conservation of linear momentum equation (<math>\Delta \vec{p}_{\text{system}} = \vec{p}_f - \vec{p}_i = \vec{F}_{\text{ave}} \Delta t</math>).</li> <li>Mathematical relationship between Linear momentum and Newton's second law for constant-mass systems (<math>\Sigma \vec{F}_{\text{external}} = \frac{m \Delta \vec{v}}{\Delta t} = m \vec{a}</math>).</li> </ul> <p><i>Exclusions:</i> <math>\vec{F}_{\text{net}}</math> and "net force" <b>until</b> students understand and automatically translate the symbol and words to "sum of external forces."</p>	
<b>TECHNICAL VOCABULARY</b>	
<ul style="list-style-type: none"> <li>impulse</li> <li>conservation of energy principle</li> </ul>	<ul style="list-style-type: none"> <li><u>totally elastic collision</u></li> </ul>

### H.B.1 Example Word Problems

You have a summer job at a company testing different sports balls.

- (a) In one experiment, an old tennis ball with a mass of 0.056 kg hits a concrete wall with a speed of 32 m/sec and bounces off with a speed of 18 m/sec. Is there a momentum transfer to the ball from the concrete wall? If so, calculate the momentum transfer by drawing a momentum diagram and using the conservation of linear momentum principle.

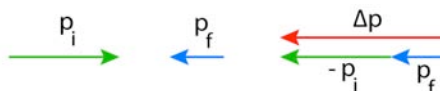

Momentum is transferred into the system by the external force of the wall acting on the ball for the duration of the collision.

$$p_{\text{in}} = F_{\text{ave}} \Delta t$$

$$\Delta p = (p_f - p_i) = F_{\text{ave}} \Delta t$$

- (b) A baseball with a mass of 150 g approaches a bat at a speed of 38.7 m/sec, and is hit straight back with a speed of 49.5 m/s. Is there a momentum transfer to the ball? If so, calculate the momentum transfer by drawing a momentum diagram and using the conservation of linear momentum principle.

### Extension Problem to Novel Situation:

A uranium nucleus at rest decays into an alpha particle and a smaller thorium nucleus. What will be the speed of this recoiling nucleus if the speed of the alpha particle is  $3.8 \times 10^5$  m/s?

**OBJECTIVE 2.3****NUCLEAR INTERACTIONS AND THE CONSERVATION OF MASS-ENERGY** (Grades 9-12)

*Students understand that nuclear interactions result in product particle(s) with less mass than the original particle(s); the missing mass appears as an energy transfer out the system. Mass-energy is conserved at all size and time scales, for all types of interactions, and for all defined systems (open or closed).*

**Table of Common Student Conceptual Difficulties**

Student Difficulty. Students often believe that:	Where Addressed	
	Essential Knowledge	Learning Outcome
1. Nuclear force: a. Electrical forces hold the protons and neutrons together in the nucleus. b. All forces are equally effective over all ranges.	H.2.3.1	H.B.1
2. Isotopes are always radioactive.	H.2.3.2	H.B.5
3. Radioactive Decay a. Atoms are like cells with a membrane and nucleus. The nucleus of an atom is the same thing as the nucleus of a cell. Nuclear decay is similar to tissue decay. Atoms can reproduce after the nuclei divide b. Atoms (electrons, protons, and neutrons) disappear during a radioactive decay. Nuclei disappear when they decay. c. Atoms cannot be changed from one element to another.	H.2.3.2 H.2.3.4	H.B.2 H.B.4
6. Beta particles are electrons, so they come from an atom's electron configuration.	H.2.3.	H.B.2
7. Fission and fusion are the same; fission is more powerful than fusion.	H.2.3.5 H.2.3.6	H.B.3 H.B.7
8. All nuclear reactions will cause a violent explosion.	H.2.3.2 H.2.3.3	H.B.2 H.B.5
9. Nuclear radiation causes cancer. Thus, it cannot be used to cure cancer. Radiation acts like a communicable disease. When radiation hits something that thing becomes radioactive. This then gives out radiation, passing the radioactive disease on like a spreading virus.	H.2.3.3	H.B.5
10. Mass is absolute -- mass doesn't change until the object is traveling at the speed of light.	H.2.3.7	H.B.6 H.B.7
11. The conservation of mass, energy, and mass-energy are useless. a. It does not help us think about or solve problems (qualitative or quantitative). b. They are not fundamental principles of science.	H.2.3.8 H.2.3.9	H.B.7 H.B.9

**Table of Content Boundaries**

<b>PHENOMENA, REPRESENTATIONS AND MODELS, AND TECHNICAL VOCABULARY</b>
<b>High School</b> (Grades 9-12)
<b>OBSERVATIONS/PHENOMENA</b> (Real World) <ul style="list-style-type: none"> <li>• <b>H.B.2</b> and <b>H.B.3</b>. Visual representations should indicate whether the nucleus changes. See example illustrations below.</li> <li>• <b>H.B.4</b>. Radioactive decays should be for common elements (e.g., Iodine 131), and as simple as possible.</li> <li>• <b>H.B.5</b>. Quantitative comparisons are not necessary – only language of essential knowledge statements H.2.3.5 and H.2.3.6.</li> </ul>
<b>REPRESENTATIONS/MODELS</b> <ul style="list-style-type: none"> <li>• Visual representations of alpha and beta decay, fission and fusion.</li> <li>• Animations and simulations of alpha and beta decay, fission and fusion.</li> <li>• Mathematical model for Mass-Energy conservation (<math>\Delta E_{\text{system}} = E_{\text{in}} - E_{\text{out}} - \Delta mc^2</math>)</li> </ul>
<b>TECHNICAL VOCABULARY</b> <ul style="list-style-type: none"> <li>• alpha and beta radioactive decay</li> </ul>

**PHENOMENA, REPRESENTATIONS AND MODELS, AND TECHNICAL VOCABULARY**

**High School** (Grades 9-12)

- fission and fusion
- isotopes

Underlined words and phrases are defined in the Glossary.

**H.B.2 and H.B.3 -- Visual Representations of Radioactive Decay, Fission, and Fusion**

Examples of visual representations of alpha and beta decay, fission, and fusion that indicate whether the nucleus changes.

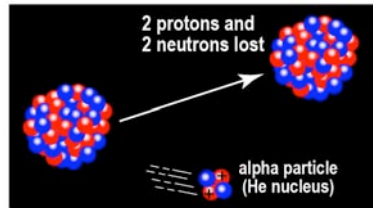

Alpha Decay

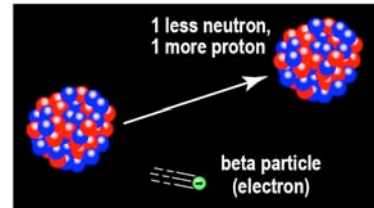

Beta Decay

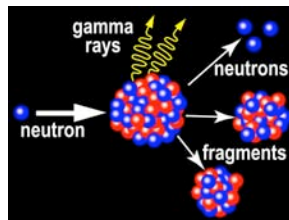

Fission

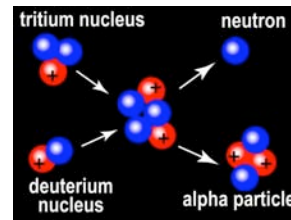

Fusion





## INSTRUCTIONAL GUIDANCE FOR STANDARD 3. NEWTON’S LAWS OF MOTION

*Interactions of an object with other objects can be described, explained, and predicted using the concept of forces, which can cause a change in motion of one or both interacting objects. Different types of interactions are identified by their defining characteristics. At the macro (human) scale, interactions are governed by Newton’s second and third laws of motion.*

### OBJECTIVE 3.1

#### CONSTANT AND CHANGING LINEAR MOTION (Grades 5-8 and Grades 9-12)

*Students understand that linear motion is characterized by speed, velocity, and acceleration, and that velocity and acceleration are vectors.*

#### **Table of Common Student Conceptual Difficulties (Grades 5- 8 and 9-12)**

Students’ conceptual difficulties with motion persist through several years. This table shows the overlap between the middle school years and high school.

Student Difficulty. Students often believe that:	Where Addressed	
	Essential Knowledge	Learning Outcome
1. The location of an object can be described by stating its distance from a given point, ignoring its direction.	E1	
2. Time can be measured without establishing the beginning of the interval.	E2 M.3.1.2	M.B.2
3. There are only two categories for describing the motion of objects, no motion (stopped) and motion (moving)	M.3.1.1 M.3.1.2 M.3.1.3	M.B.1 M.B.2 M.B.3
4. When an object moves with a series of constant speeds, average speed is always the same as the average of the speeds.	M.3.1.1c	M.B.5 M.B.6
5. Students have difficulty interpreting the meaning of “average” for the continuously changing motion quantities of speed and velocity: a. average speed; b. average velocity; c. average acceleration	M.3.1.4  H.3.1.3 H.3.1.6	M.B.7  H.B.2 H.B.6
6. An object’s speed is the same as its velocity.	H.3.1.1 H.3.1.2	H.B.5
7. The distance an object travels and its displacement are always the same.	H.3.1.1	H.B.1 H.B.5
8. Students have difficulty distinguishing between: a. position and speed or velocity [e.g., two objects with identical positions (at an instant) have identical speeds]. b. velocity and acceleration [e.g., two objects with identical velocities (at an instant) have identical accelerations; larger (smaller) velocity means larger (smaller) acceleration].	H.3.1.2  H.3.1.5	H.B.6  H.B.5 H.B.6
8. Constant velocity and instantaneous velocity are the same.	H.3.1.2 H.3.1.4	H.B.5 H.B.6
9. An object that has zero velocity at an instant cannot be accelerating.	H.3.1.4	H.B.2 H.B.8

### Grades 5-8

**PHENOMENA, REPRESENTATIONS AND MODELS, AND TECHNICAL VOCABULARY**

**Middle School** (Grades 5-8)

**OBSERVATIONS/PHENOMENA** (Real World)

- **Objects:** skateboarders, cars, and skiers; low-friction cart, puck-balloon system, battery operated toy car, motion detectors.
- **Events:** Rolling or sliding in straight lines on horizontal surfaces, up an inclined surface, or down an inclined surface.
- **M.B.6.** Limit the problems for an object moving in a series of constant speeds to no more than three segments, and keep the numbers simple so students can focus on the results. An example problem is shown below.

*Exclusions:* Two- or three-dimensional motion

**REPRESENTATIONS/MODELS**

- Pictures, diagrams, or drawings of objects moving in a straight line on horizontal or inclined surfaces.
- Computer animations or simulations.
- Motion diagrams (see Glossary)
- Data tables and graphs of distance versus time.
- Mathematical representations (equations) for constant speed and average speed [speed = distance-traveled/time-of-travel]

**TECHNICAL VOCABULARY**

- constant speed
- average speed

*Exclusions:* velocity, acceleration

Underlined words and phrases are defined in the Glossary.

**M.B.2 Example Problems**

A car is slowing down. Write a verbal description of slowing down, and draw a distance versus time graph and a motion diagram for this pattern of motion.

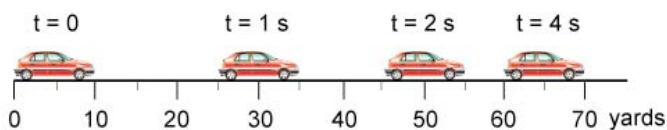
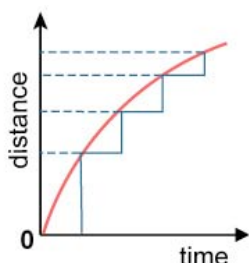

The car is slowing down, so it travels a shorter distance in each successive time interval.

**M.B.6 Example Problem**

On a long car trip with your friend, the car traveled at 45 mi/hr for one hour though a construction zone, then traveled at 65 mi/hr for the next three hours. What was the average speed of the car? Interpret the meaning of the average speed.

*In this case, the average speed is 60 mi/hr, which is different from the average of the two speeds (55 mi/hr). The car could have traveled at a constant speed to 60 mi/hr and reached the destination in the same time.*

**M.B.5 Example Problem**

At the right is a student's calculation of the average speed of a remote operated car. Analyze the solution and determine whether the average speed was calculated correctly. Explain your reasoning. If correct, interpret the meaning of the average speed. If incorrect, describe how to calculate the average speed correctly.

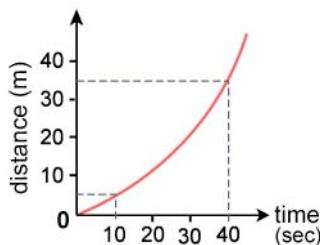

The average speed from t = 10 sec to t = 40 sec is:

$$\begin{aligned} \text{speed} &= \frac{\left( \frac{5 \text{ m}}{10 \text{ s}} + \frac{35 \text{ m}}{40 \text{ s}} \right)}{2} \\ &= \frac{0.5 \text{ m/s} + 0.875 \text{ m/s}}{2} \\ &= 0.69 \text{ m/s} \end{aligned}$$

The average speed from  
t = 10 sec to t = 40 sec is:

$$\begin{aligned} \text{ave. speed} &= \frac{\text{total distance}}{\text{total time interval}} \\ &= \frac{35 \text{ m} - 5 \text{ m}}{40 \text{ s} - 10 \text{ s}} \\ &= 1 \text{ m/s} \end{aligned}$$

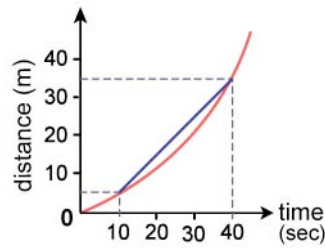

**Example Answer.** *The solution is wrong because the average speed is not the average of the two speeds. To calculate the average speed, you have to know the total distance traveled and the total time of travel. This is the slope of the line from the beginning time to the end time – see my graph.*

## Grades 9-12

### Table of Content Boundaries

<b>PHENOMENA, REPRESENTATIONS AND MODELS, AND TECHNICAL VOCABULARY</b>
<b>High School (Grades 9-12)</b>
<p><b>OBSERVATIONS/PHENOMENA</b> (Real World)</p> <ul style="list-style-type: none"> <li>The same objects and events as in middle school, but with more complex motions (e.g., an object rolls/slides up then back down an inclined surface; an object rolls/slides down an inclined surface then up a different inclined surface; object moves in a series of speeding up, constant speed, and slowing down motions, etc.</li> </ul> <p><i>Exclusions:</i> two- or three-dimensional motion</p>
<p><b>REPRESENTATIONS/MODELS</b></p> <ul style="list-style-type: none"> <li>Computer animations and simulations</li> <li><u>Motion diagrams</u> (see Glossary and example H.B.7 below)</li> <li><u>Vector subtraction</u> (see Glossary)</li> <li>Data tables and graphs of position versus time <i>and</i> velocity versus time</li> <li>Mathematical representations (equations) for constant and average velocity [<math>\vec{v} = (x_f - x_i)/(t_f - t_i)</math>], constant and average acceleration [<math>\vec{a} = (v_f - v_i)/(t_f - t_i)</math>], and the relationship between average and instantaneous velocities for constant acceleration [When acceleration is constant, <math>v_{\text{ave}} = v_f + v_i/2</math>].</li> <li><u>Analogue model</u> of instantaneous velocity: readings on a speedometer</li> </ul> <p><i>Exclusions:</i> No other kinematics equations</p>
<p><b>TECHNICAL VOCABULARY</b></p> <ul style="list-style-type: none"> <li>displacement</li> <li>constant and average velocity</li> <li>instantaneous velocity</li> <li>constant and average acceleration</li> </ul> <p><i>Exclusions:</i> The term “deceleration” (see H.3.1.4).</p>

Underlined words and phrases are defined in the Glossary.

### H.B.6 Example Problems

- Example#1: An object is slowing down faster and faster in the negative direction. Draw a motion diagram (and/or draw an instantaneous velocity versus time graph) that represent(s) this motion.
- Example #2: For the graph below (not shown here), write a verbal description (and/or draw a motion diagram) that represent(s) the motion of the object.
- Example #3: For the motion diagram below (not shown here), write a verbal description (and/or draw an instantaneous velocity versus time graph) that represents the motion of the object.

### H.B.6 Examples of Verbal Descriptions of Motion

Write a verbal description of the motion illustrated in each of the graphs below.

- The object is speeding up slower and slower in the positive direction.
- The object is moving with a constant velocity in the positive direction.
- The object is slowing down at a constant rate (constant acceleration) in the negative direction.
- The object is slowing down slower and slower in the negative direction.
- The object is speeding up at a constant rate (constant acceleration) in the positive direction.
- The object is not moving.
- The object is moving with a constant velocity in the negative direction.
- The object is slowing down faster and faster in the negative direction.
- The object is speeding up faster and faster in the positive direction.

Of course, students should develop their own language – these are only examples.

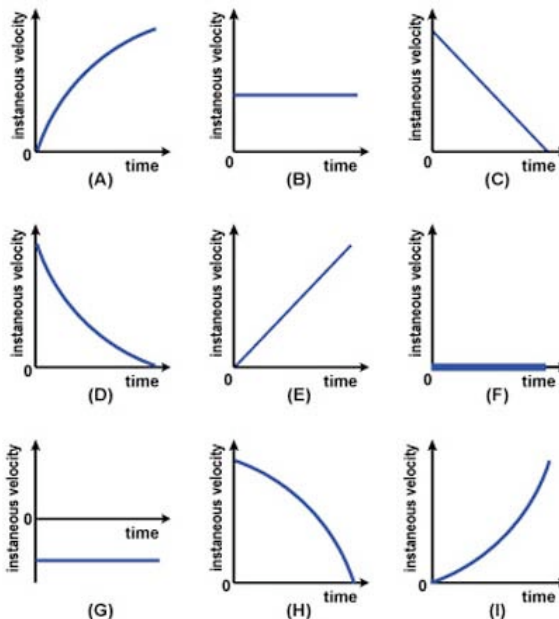

### H.B.7 Example Problem

You and your friend are practicing for the next marathon race for your favorite charity. Your friend finishes warming up first, so she starts running the marathon route at a constant speed of 3 m/s. A few minutes later, another friend arrives with an urgent message. You start off 5 minutes after your friend, running at a constant speed of 4 m/s. How far from the starting point will you catch up to your friend?

*Partial Answer*

The equations for constant velocity is applied to “you” and the friend:

$$v = \frac{x_f - x_i}{t_f - t_i}$$

$$v_{\text{friend}} = \frac{x_f}{t_f} = 3 \text{ m/s}, \quad x_f = 3t_f$$

$$v_{\text{you}} = \frac{x_f}{t_f - 5 \text{ min}} = 4 \text{ m/s}, \quad x_f = 4(t_f - 5)$$

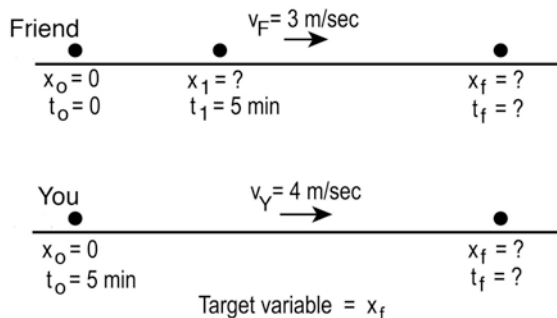

### H.B.8 Example Problem

Just for the fun of it, you and a friend decide to enter the state bicycle race. You are riding along at a comfortable speed of 20 mph when you see in your mirror that your friend is going to pass you at what you estimate to be a constant 30 mph. You will, of course, take up the challenge and accelerate just as she passes you until you pass her. If you accelerate at a constant 0.25 miles per hour each second until you pass her, how long will she be ahead of you?

*Solution requires good motion diagram and use of three equations,  $\bar{v} = (x_f - x_i)/(t_f - t_i)$ ,  $\bar{a} = (v_f - v_i)/(t_f - t_i)$ , and*

*$v_{\text{ave}} = v_f + v_i/2$  for constant acceleration.*

**OBJECTIVE 3.2****FORCES AND CHANGES IN MOTION (Grades 5-8 and Grades 9-12)**

Students understand that interactions can be described in terms of forces. The acceleration of an object is proportional to the vector sum of all the forces (net force) on the object and inversely proportional to the object's mass ( $\vec{a} = \Sigma \vec{F} / m$ ). When two interacting objects push or pull on each other, the force on one object is equal in magnitude but opposite in direction to the force on the other object.

**Table of Common Student Conceptual Difficulties, Grades 5-8 and Grades 9-12**

Students' conceptual difficulties with forces persist through several years. This table shows the overlap between the middle school years and high school.

Student Difficulty. <sup>†</sup> Students often believe that: Note: All students have undifferentiated concepts of force, energy, and power, and these terms are often used interchangeably.	Where Addressed	
	Essential Knowledge	Learning Outcome
1. Failure to distinguish between motion and change in motion: a. When an object is in motion (even constant velocity), then there must be a force acting on the object. b. The amount of motion (velocity) is proportional to the force, so acceleration requires an <i>increasing</i> force (when velocity and acceleration are undifferentiated concepts). c. There cannot be a force without motion, and if there is no motion, then there is no force acting.	M.3.2.2 H.3.2.2a H.3.2.3	M.B.1 M.B.2 H.B.1 H.B.2 H.B.5
2. Sum of Forces a. The largest force determines motion, or some force compromise determines motion, or the last force to act determines motion (difficulty relating the "sum of forces" or "net force" and the motion of an object). b. The "net" force or "the product of mass times acceleration" (sometimes called the "ma" force) is a force acting on all moving or accelerating objects, and is unrelated to the other forces acting on the object.	M.3.2.2e H.3.2.2a	M.B.3 M.B.4 M.B.6 H.B.2 H.B.3 H.B.6
3. Circular Motion and Forces a. An object moving in circle with constant speed has no acceleration. b. Circular motion does not require a force. c. An object moving in a circle will continue in circular motion when released, or fly out radially when released.	M.3.2.2d H.3.2.2c	M.B.2 M.B.6 H.B.7
4. Newton's Third Law a. The larger, stronger, or more active object exerts a greater force on the smaller object than the smaller, weaker or passive object exerts on the larger object. Newton's third law can be "overcome" by motion (such as by a jerking motion). b. The interaction or third-law pair of forces acts on the same object. c. The interaction or third-law pairs are the same as the "balanced" forces on a single object at rest (e.g., an object's weight and the "normal" force are identified as third-law pairs). d. Friction is the same as "reaction" [if students learn that "for every reaction there is an equal and opposite reaction].	H.3.2.3	H.B.5

<sup>†</sup> For conceptual difficulties with specific types of forces, see Objectives 3.3, 3.4 and 3.5, and 5.1

**Grades 5-8****Table of Content Boundaries**

<b>PHENOMENA, REPRESENTATIONS AND MODELS, AND TECHNICAL VOCABULARY</b>
<b>Middle School (Grades 5-8)</b>
<b>OBSERVATIONS/PHENOMENA</b> (Real World) <ul style="list-style-type: none"> <li><b>Interactions.</b> Simple horizontal and circular contact interactions (see Objective 3.3), horizontal magnetic and electric charge interactions (see Objective 3.5); and vertical gravitational interactions (see Objective 3.4).</li> </ul> <i>Exclusions:</i> At rest situations; collision interaction between rigid solids; and two- or three-dimensional motion.

**PHENOMENA, REPRESENTATIONS AND MODELS, AND TECHNICAL VOCABULARY**

**Middle School** (Grades 5-8)

**REPRESENTATIONS/MODEL**

- Force diagrams
- Motion diagrams
- Animations and computer simulations

*Exclusions:* force diagrams that (1) do not isolate the object from the surrounding objects, or (2) draw all the forces from one point at the center of the object.

**TECHNICAL VOCABULARY**

- force
- sum of forces
- vector addition (one dimension)

*Exclusions:* The phrases “net force” and “unbalanced force” should be avoided because of the conceptual difficulty middle school students have understanding and using these phrases

Underlined words and phrases are defined in the Glossary.

**M.B.1: Experiment**

The classic experiment for the relationship between a constant force applied to an object and its pattern of motion is from PSSC Physics (Haber-Shaim, Gardner, Dodge, Shore, & Walter, 1991). Attach a long rubber band to a low friction toy car or cart, and have students take turns running with the cart down a hallway (or in the cafeteria), keeping the force constant (the rubber band stretched the same length). This kinesthetic experience of running faster and faster is helpful in addressing students’ misconception that a constant force is needed for a constant velocity.

**M.B.4: Example Problem**

A large magnet attracts a paper clip. At right is the force diagram for the paper clip.

- Predict the object’s pattern of motion and justify using Newton’s second law.
- The frictional force is one-half the size of the magnetic force. Use vector addition to determine the size and direction of the sum of the forces, and interpret the meaning of the sum of the forces.

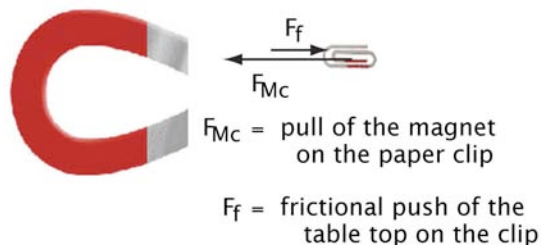

**M.B.6: Example Problem and Solution**

A man with a parachute is falling towards the Earth at a constant speed.

- What types of interactions are involved in this situation. Explain your reasoning.
- Represent the forces acting on the man-parachute system by drawing a force diagram. Use vector addition to show the sum of forces on the man-parachute system.
- Explain the observed motion of the man-parachute system based on Newton’s second law.



$F_G$  = gravitational pull of the Earth on the man-parachute system  
 $F_D$  = drag push of the air on the man-parachute system

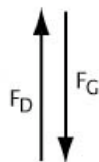

According to Newton’s second law, the sum of the forces on a system causes the motion of the system to change (speed up, slow down, or change direction). In this case, the man-parachute system is moving with a constant speed, so the sum of the forces is zero.

**Grades 9-12**

**Table of Content Boundaries**

<b>PHENOMENA, REPRESENTATIONS AND MODELS, AND TECHNICAL VOCABULARY</b>
<b>High School (Grades 9-12)</b>
<p><b>OBSERVATIONS/PHENOMENA</b> (Real World)</p> <ul style="list-style-type: none"> <li>• <b>Same Interactions as for middle school</b>, but more complex motions and multiple interactions, including: motion in two parts; situations involving two objects; objects at rest – suspended vertically or sitting on another object; and drag and static friction interactions with one object an energy source (e.g., walking, moving car, helicopter).</li> </ul> <p><i>Exclusions:</i> Collision interactions between rigid solids (see Objective 2.3); and projectile or three-dimensional motion.</p>
<p><b>REPRESENTATIONS/MODELS</b></p> <ul style="list-style-type: none"> <li>• <u>Force diagrams</u></li> <li>• <u>Motion diagrams</u></li> <li>• <u>Vector addition</u></li> <li>• Animations and computer simulations</li> <li>• “<math>\Sigma</math>” symbol to represent “sum of”</li> <li>• Mathematical representation of Newton’s Second Law (<math>\Sigma \vec{F} = m\vec{a}</math>) and Newton’s third law (<math>\vec{F}_{12} = -\vec{F}_{21}</math>).</li> </ul> <p><i>Exclusions:</i> Force diagrams that (1) do not isolate the object from the surrounding objects, and/or (2) draw all the forces from one point at the center of the object.</p>
<p><b>TECHNICAL VOCABULARY</b></p> <ul style="list-style-type: none"> <li>• Newton’s second law of motion</li> <li>• Newton’s third law of motion</li> <li>• interaction pair of forces</li> <li>• net force</li> </ul> <p><i>Exclusions:</i> inertia; action/reaction pair; deceleration (see Objective 2.1)</p>

Underlined words and phrases are defined in the Glossary.

**H.B.1 Example Problem**

A car accelerates from 55 mph to 65 mph as it moves to the right along a straight road.

- (1) Which of the horizontal force diagrams above is correct?
- (2) Give a brief verbal description of each force.
- (3) Determine the sum of the forces for this problem. Interpret the meaning of the sum of the forces.

*Note: (b) is the correct force diagram.*

**H.B.5 Example Problem**

Example #1. A bird is sitting on the branch of a tree. What is the third law interaction pair to the force (push) of the branch on the bird? Explain your reasoning.

Example #2. A bird is sitting on the branch of a tree. Draw force diagrams that show the third-law interaction pairs of the forces acting on the bird.



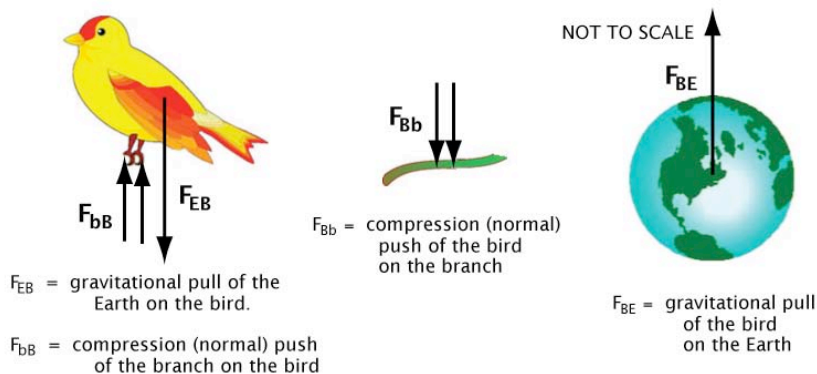

In this case, the third law interaction pairs are  $F_{bB} - F_{BB}$ , and  $F_{EB} - F_{BE}$

### OBJECTIVE 3.3

#### CONTACT INTERACTIONS AND FORCES (Grades 5-8 and Grades 9-12)

Students understand that contact interactions occur when two objects in contact push or pull on each other, which can cause a change in motion of one or both objects. Some types of contact interactions have force laws that are empirical approximations; some have no force laws.

#### Table of Common Student Conceptual Difficulties, Grades 5-8 and Grades 9-12

Students' conceptual difficulties with contact forces persist through several years. This table shows the overlap between the middle school years and high school.

Student Difficulty. <sup>+</sup> Students often believe that:	Where Addressed	
	Essential Knowledge	Learning Outcome
1. The Nature of Forces a. Force is an intrinsic property of objects (e.g., "motive power" or "inertia") that <i>keeps them moving</i> (e.g., force of momentum, force of inertia), rather than a property of an interaction. b. Only "active agents" (e.g., metaphor for living things) can exert forces – active agents have the power to <i>cause</i> motion – to create "motive power" or "inertia" and transfer it to other objects. For example, the "force of the hit," and "the force of the hand" are forces transferred to an object by a person, the active agent.	M.3.3.3	M.B.1 M.B.3 M.B.4
2. A push is in the same direction as a pull (difficulty distinguishing between pushes and pulls).	M.3.3.4 H.3.3.2 H.3.3.3	M.B.1 M.B.2 H.B.5
3. Drag Forces a. Drag interactions occur in liquids, but not in gases. b. "Resistance to motion" means the same thing as friction, so drag is the same as friction.	M.3.3.4c M.3.3.4d H.3.3.4	M.B.3 M.B.6 H.B.6
4. Frictional Forces a. Friction is not a force – it is an "obstacle" that must be overcome by the forces transferred to the object.	H.3.3.5	H.B.5
b. Friction depends on movement, so if an object is not moving, there can be no frictional force.	H.3.3.2c	H.B.3 H.B./6
c. Friction always hinders motion. Thus, you <i>always</i> want to eliminate friction.	H.3.3.4b H.3.3.4c	H.B.3
d. Frictional forces are only due to irregularities in surfaces moving past one another (frictional forces increase with the "roughness" of the surfaces).	H.3.3.6	H.B.8
5. Stationary Objects. At rest is a natural state in which no forces are acting on the object. Passive objects (e.g., floor, walls, chair, table, ropes or strings, attachment for a pendulum, and especially air) cannot exert forces. a. Air pressure, gravity, or an intervening object (like a table) "gets in the way" and keeps an object stationary.	H.3.3.3a	H.B.5 H.B.6



Student Difficulty. <sup>†</sup> Students often believe that:	Where Addressed	
	Essential Knowledge	Learning Outcome
b. A "holding up" force is different from the typical pushing or pulling forces. c. The downward force of gravity on a book must be greater than an upward force for the book to be stationary. d. "Normal" means usual, so there is always an upward "usual" force on <i>all</i> objects in <i>all</i> situations that is equal to the weight of the object.		

<sup>†</sup>See also Objective 3.2 for conceptual difficulties with Newton's laws of motion.

## Grades 5-8

### Table of Content Boundaries

PHENOMENA, REPRESENTATIONS AND MODELS, AND TECHNICAL VOCABULARY
Middle School (Grades 5-8)
<p><b>OBSERVATIONS/PHENOMENA</b> (Real World)</p> <ul style="list-style-type: none"> <li>Horizontal linear motion and circular motion</li> <li><b>Applied interaction.</b> Simple events like humans, ropes, car with hitched trailer, pulling or pushing on another solid system with negligible friction or drag (e.g., low-friction carts, puck-balloon system, a human-skateboard system, ice skater system, kicking a soccer ball or batting a softball, whirling object horizontally on the end of a string) etc. [Note: Whirling object can never be purely horizontal. If whirled fast enough, however, the small vertical component can be ignored.]</li> <li><b>Elastic Interaction.</b> Simple events like springs and rubber bands pulling or pushing horizontally on another solid system with negligible friction or drag, etc.</li> <li><b>Drag Interaction.</b> Simple events like boat moving through water; big solid objects moving through air; wind moving solid objects:</li> <li><b>Sliding (kinetic) Friction Interaction.</b> Everyday simple events like books, boxes, or cars with brakes on, sliding over another surface and slowing down, etc.</li> <li><b>M.B.3.</b> Examples of a change in shape of an object include: a crumpled piece of paper is flattened; a thin, flat piece of Styrofoam is dropped with flat side facing down and thin edge facing down.</li> <li><b>M.B.5.</b> Examples include skateboarder with shoulders facing forward turns sideways so one shoulder faces forward; the sail of boat in different positions with respect to the wind; bicyclist sits straight up then crouches down; changing the shape of the bow of a boat; and skydivers changing their shape as they fall.</li> </ul> <p><i>Exclusions:</i></p> <ul style="list-style-type: none"> <li>Vertical, projectile, or three-dimensional motion.</li> <li>Elastic interactions between rigid bodies; at-rest situations (e.g., book sitting on the table); gravitational interactions; static friction interactions; interactions which require Newton's third law;</li> </ul>
<p><b>REPRESENTATIONS/MODELS</b></p> <ul style="list-style-type: none"> <li>Same as for Objective 3.2.</li> </ul>
<p><b>TECHNICAL VOCABULARY</b></p> <ul style="list-style-type: none"> <li>applied interaction</li> <li>elastic interaction</li> <li>friction interaction</li> <li>drag interaction</li> </ul>

Underlined words and phrases are defined in the Glossary.





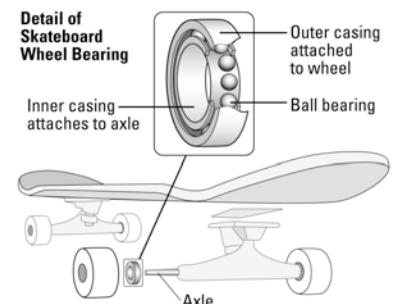

### Information About Rolling Friction

Most wheeled objects, like the skateboard shown at right, have a wheel bearing. The inner casing of the wheel bearing is attached to the axle and does not spin. The wheel is attached to the outer casing, which rolls over the ball bearings and allows the wheel to spin.

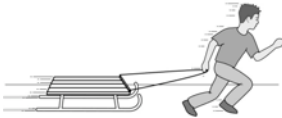

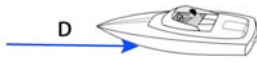

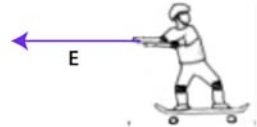

The ball bearings rub against the casings, and a force is exerted by the wheel on the axle-object system.



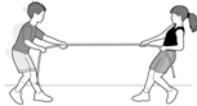

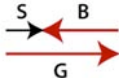
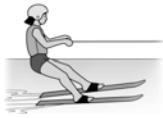
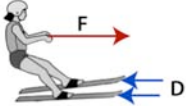
**M.B.1 Example Problem Situations and Force Diagrams<sup>1</sup>**

Problem Situation	Force Diagram
1. The sled is speeding up. 	 <p>F = applied pull of the boy on the sled</p>
2. The boat is slowing down after it runs out of gas. 	 <p>D = drag push of the water on the boat</p>
3. The skateboarder is slowing down as he holds onto the branch of the tree as he moves to the right. 	 <p>E = elastic pull of the tree branch on the skateboarder</p>
4. The box of cookies is slowing down as it slides to the right along a table. 	 <p>f = sliding friction push of the table top on the box</p>

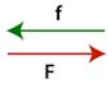
**M.B.4 Problem Situations and Vector Addition Diagrams**

Problem	Force Diagram	Answer
1. Explain why the rope is speeding up to the right. 	 <p>G = the applied pull of the girl on the rope B = the applied pull of the boy on the rope</p>	<p>According to Newton's second law, the rope is speeding up to the right because the pull of the girl on the rope (<b>G</b>) is larger than the pull of the boy on the rope (<b>B</b>). So the sum of the two forces (<b>S</b>) is directed to the right.</p> 
2. Explain why the skier is moving with a constant speed to the right. 	 <p>F = the applied pull of the rope on the skier D = the drag push of the water on the skier</p>	<p>According to Newton's second law, the skier is moving at a constant speed because the sum of the two drag forces of the water on the skier (<b>D</b>) is equal in magnitude but in the opposite direction from the pull of the rope on the skier (<b>F</b>). So the sum of the forces on the skier is zero.</p> 
4. Explain why the shopping cart is moving with a constant speed. 	 <p>F = the applied push of the girl on the shopping cart f = the rolling frictional push of the rubbing parts of the wheel on the cart</p>	<p>According to Newton's second law, the cart is moving at a constant speed because the applied push of the girl on the cart (<b>F</b>) is equal in magnitude but opposite in direction from the rolling friction push of the wheels on the cart (<b>f</b>). So the sum of the forces on the cart is zero.</p> 

<sup>1</sup> From Goldberg, F., Bendall, S., Heller, P. & Poel, R., 2006.

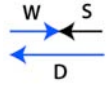
<p>3. Explain why the sailboat is speeding up to the left.</p> 	 <p>D = the drag push of the wind on the sails of the boat W = the drag push of the water on the sailboat</p>	<p>According to Newton's second law, the sailboat is speeding up to the left because the drag push of the wind (D) in the sails is larger than the opposite drag push of the water in the boat (W). So the sum of the forces (S) is directed to the left.</p> 
--	--	---

**M.B.4 Example Problem Involving Circular Motion**

- Imagine rolling a ball along a curved track like the one shown here. What will the ball's path be once it reaches the end of the track? Will it continue to roll in a circle? Will it roll in a straight line? Will it do something else?<sup>2</sup>
- Analyze the problem.
  - Identify the type of interaction of the ball with the track.
  - Draw a force diagram of the ball for each position of the ball.
  - Explain the circular motion of the ball while it is rolling inside the track based on Newton's second law.
- Your teacher will demonstrate what happens to the ball when it reaches the end of the track. Explain the motion of the ball based on Newton's second law.

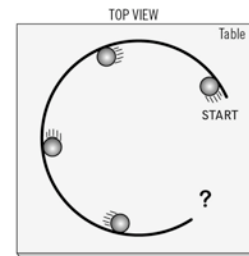
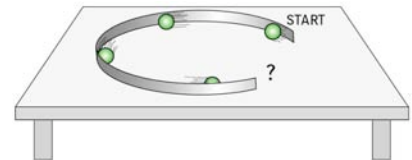

**Grades 9-12**

**Table of Content Boundaries**

PHENOMENA, REPRESENTATIONS AND MODELS, AND TECHNICAL VOCABULARY	
High School (Grades 9-12)	
<b>OBSERVATIONS/PHENOMENA (Real World)</b>	
<ul style="list-style-type: none"> <li>Horizontal or vertical motion</li> <li><b>Same objects</b> as for middle school, but more complex situations.</li> <li><b>Compression ("normal") Interaction.</b> Simple at-rest situations; pressing a solid object against the wall; charged balloon stuck to a wall, among many other examples.</li> <li><b>Tension Interaction.</b> Simple situations like an object suspended by a cord; cords pulling on objects horizontally.</li> <li><b>Static Friction Interaction.</b> Simple situations like pushing or pulling on heavy boxes or furniture on different surfaces; situations where static friction is necessary to allow an object to move.</li> <li><b>Static Friction and Drag Interactions Where One Object is an Energy Source.</b> Examples include: a drag interaction between kayaker-paddle system (energy source) and the water (interacting system); a drag interaction between the electric source-motor-rotating blades on helicopters or boat (energy sources) and the air or water (interacting systems); a static friction interaction between a person's feet (energy source) and the ground (interacting object) when the person starts to walk; and a static friction interaction between the wheels of a car (energy source) and the ground (interacting object), among many other examples.</li> <li><b>H.B.1.</b> Range of different grains of sand paper (from very rough to extra fine) to illustrate that kinetic friction does not increase as the roughness of the surface. increases (sliding object constant. . Friction is caused by the attraction between the atoms or molecules of the two objects, and increases as the compression between the two surfaces increases.</li> </ul>	
<i>Exclusions:</i>	
<ul style="list-style-type: none"> <li>Projectile or three dimensional motion</li> <li>Collision interactions (See Objective 2.3)</li> </ul>	

<sup>2</sup> Arons, 1977

**PHENOMENA, REPRESENTATIONS AND MODELS, AND TECHNICAL VOCABULARY****High School** (Grades 9-12)**REPRESENTATIONS/MODELS**

- Mathematical representation of elastic force,  $F_{\text{elastic}} = k\Delta x$ .
- Mathematical representation of kinetic friction force,  $F_k = \mu_k N$ .
- Mathematical representation of static friction force,  $F_s \leq \mu_s N$
- Same as Objective 3.2

**TECHNICAL VOCABULARY**

- tension interaction
- compression(normal) interaction
- kinetic friction interaction
- static friction interaction
- force laws

**H.B.3 and H.B.4 Kinetic and Static Friction Coefficients**

Surfaces	kinetic ( $\mu_k$ )	static ( $\mu_s$ )
rubber on concrete (dry)	0.8	1.0
rubber on concrete (wet)	0.25	0.30
Teflon on Teflon	0.04	0.04
Teflon on steel	0.04	0.04
steel on steel	0.07	0.06
metal on metal (lubricated)	~0.06	0.15
ice on ice	0.03	0.10
waxed wood on dry snow	0.06	0.10
waxed wood on wet snow	0.10	0.14
wood on wood	0.02	0.25-0.50

Sometimes the goal is to reduce friction (e.g., engine oil and other lubricants), and sometimes the goal is to increase friction (e.g., brake linings, driving belts, soles of shoes, and tires).

**OBJECTIVE 3.4****GRAVITATIONAL INTERACTIONS AND FORCES** (Grades 5-8 and Grades 9-12)

*Students understand that gravity is an attractive interaction between any two objects with mass, which can cause a change in motion of the objects. Gravitational interactions are governed by a force law.*

**Table of Common Student Conceptual Difficulties, Grades 5-8 and Grades 9-12**

Students' conceptual difficulties with gravitational forces persist through several years. This table shows the overlap between the middle school years and high school.

Student Difficulty <sup>+</sup> Students often believe that:	Where Addressed	
	Essential Knowledge	Learning Outcome
1. Shape of Earth and Up-Down	M.3.4.1	M.B.1

Student Difficulty <sup>+</sup> Students often believe that:	Where Addressed	
	Essential Knowledge	Learning Outcome
a. The Earth is round like a pancake. b. We live on the flat middle of a sphere. c. There is a definite up and down in space.		M.B.3
2. "Gravity" is not associated with an interaction between two objects. "Gravity" is not necessarily the same as "gravitational force."	M.3.4.2 H.3.4.2	M.B.1 H.B.2
3. Gravity is caused by the earth's magnetism, or the spinning earth (planets that spin faster have more gravity), or by air pressure (there is no gravity in a vacuum).	M.3.4.2	M.B.2 M.B.3
4. The force that acts on an apple is not the same as the force that acts on the Moon.	M.3.4.2b	M.B.4
5. There is no gravitational force in space. Objects in orbit are weightless, so gravity does not affect them.	H.3.4.4	H.B.5
6. Magnitude of the Earth's Gravitation Force a. The gravitational force is the same on all falling objects. b. Gravity varies significantly over a few meters of height above the Earth's surface.	H.3.4.3	H.B.2
c. The gravitational force is much stronger than the magnetic and electrical forces (because it keeps the planets in their orbits).	M.3.4.3	M.B.5
d. Near the surface of the earth, heavier objects fall faster than lighter objects.	H.3.4.2 H.3.4.4	H.B.1
7. The gravitational forces on interacting objects are not equal and opposite – the gravitational pull of the Earth on an object is much larger than the gravitational pull of the object on the Earth.	H.3.4.2	H.B.5
8. Mass and Weight a. Mass and weight are the same and they are equal at all times. b. Weight is not the same as the gravitational pull of the Earth on an object. Objects fall because of two things acting separately, gravity and the weight of an object (or the product of "m times g").	M.3.4.4	M.B.7

+ See also conceptual difficulties in Objective 5.1 (Forces and Fields)

## Grades 5-8

### Table of Content Boundaries

PHENOMENA, REPRESENTATIONS AND MODELS, AND TECHNICAL VOCABULARY
Middle School (Grades 5-8)
<p><b>OBSERVATIONS/PHENOMENA</b> (Real World)</p> <p><b>Objects.</b> Everyday examples of objects released and falling; or throwing small objects straight up or down</p> <p><b>Events.</b> Circular orbits of moons around planets; orbits of planets around sun.</p> <p><b>M.B.2.</b> Video demonstration of weight suspended by spring scale inside a vacuum chamber is one appropriate resource.</p> <p><i>Exclusions:</i> At-rest situations; projectile motion and three-dimensional motion</p>
<p><b>REPRESENTATIONS/MODELS</b></p> <ul style="list-style-type: none"> <li>Same as for Objective 3.2</li> </ul>
<p><b>TECHNICAL VOCABULARY</b></p> <ul style="list-style-type: none"> <li>Label for gravitational force on <u>force diagrams</u>: "gravitational pull of the ... [planet or moon] on the ... [system of interest.]"</li> </ul> <p><i>Exclusions:</i> The phrase "force of gravity" should be avoided as much as possible. Substitute "gravitational pull of the Earth."</p>

### M.B.1 Example Problem situations<sup>3</sup>

Example #1. In this picture, four people holding balls are standing on different parts of the Earth. Suppose each person lets go of his or her ball. On the picture draw the path that shows how each person's ball would fall. Explain why the balls follow the paths you drew.

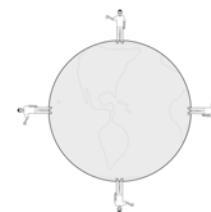

<sup>3</sup> From Goldberg, F., Bendall, S, Heller, P. & Poel, R., 2006.

**Example #2.** Four helicopters are hovering over the Earth as shown in the picture. Each helicopter has a crate of supplies to be delivered to Red Cross sites. On the picture draw how each helicopter's crate would fall when the crates are released. Write your reasons for your drawing. Explain why the crates follow the paths you drew.

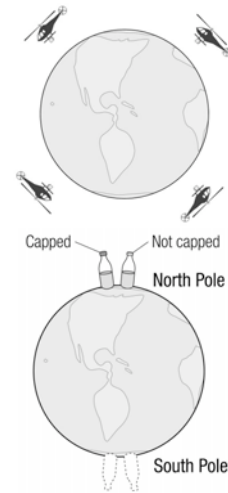

**Example #3.** An explorer has two half-filled water bottles at the North Pole. One bottle is capped and the other is not. Suppose the explorer travels to the South Pole and sets her bottles down. Draw on the sketch to show what will happen to the water in the bottles. Explain your sketches.

**M.B.2 Example Responses<sup>1</sup>**

**Air pressure is not the cause of the gravitational interaction.** An object is placed on a scale in a bell jar. The air is then evacuated out of the bell jar. The object does not begin to float and its scale measurement did not change. Because there was no change observed, the gravitational interaction cannot be due to air pressure. (Demonstration or Video)



**Earth's rotation is not the cause of the gravitational interaction.** A string is attached to the rim of a bucket, and the bucket is rotated around its vertical axis. The string straightened up (pointed outward) when the bucket rotated. The gravitational interaction is not caused by Earth's rotation because if it were the string would not have moved outward, pointing away from the bucket, when the bucket was rotated. Rather, it should have moved inward, toward the bucket and rested itself on the bucket.



**Earth's magnetism is not the cause of gravity.** The gravitational interaction is always attractive (objects are pulled toward each other); magnetic interactions are sometimes repulsive. Also, there is a magnetic attraction between a magnet and some metals, but there is a gravitational attraction between Earth and ALL objects.



**M.B.9 Example Problem**

- a. A skydiver jumps out of a plane at 30,000 feet and spreads out her arms and legs, as shown. After a few seconds, she falls with a constant speed. Why?
  - (i) Identify the object(s) interacting with the skydiver. Determine the type(s) of interaction(s) based on the characteristics of different types of interactions.
  - (ii) Draw a force diagram of the skydiver.
  - (ii) Explain why the skydiver falls with a constant speed (called her terminal velocity)



- b. The skydiver moves so she is falling as shown. Predict what will happen to her pattern of motion as she falls. Will she continue falling at a constant speed? Will she speed up? Slow down? Explain your reasoning.



## Grades 9-12

### Table of Content Boundaries

PHENOMENA, REPRESENTATIONS AND MODELS, AND TECHNICAL VOCABULARY High School (Grades 9-12)
<p><b>OBSERVATIONS/PHENOMENA</b> (Real World)</p> <ul style="list-style-type: none"> <li>• <b>Events.</b> Everyday examples of small objects falling, or throwing small objects straight up. Circular orbits of satellites around Earth, moons around planets; orbits of planets around sun.</li> <li>• <b>H.B.9.</b> See Instructional Guidance for Standard 1, Objective 1.1</li> <li>• Projectile motion could be done as an extension activity (see example below)</li> </ul> <p><i>Exclusions:</i> two and three dimensional motion</p>
<p><b>REPRESENTATIONS/MODELS</b></p> <ul style="list-style-type: none"> <li>• Same as for objective 3.2</li> <li>• <math>g</math> has the units of Newtons per kilogram</li> </ul>
<p><b>TECHNICAL VOCABULARY</b></p> <ul style="list-style-type: none"> <li>• Label for gravitational force on <u>force diagrams</u>: “gravitational pull of the <u>planet or moon</u> on <u>system of interest</u>”</li> </ul> <p><i>Exclusions:</i> The phrase “force of “gravity” should be avoided as much as possible. Substitute “gravitational pull of the Earth.”</p>

Underlined words and phrases are defined in the Glossary.

#### Extension: Projectile Motion

Research indicates that the independence of the orthogonal components of a vector is a very difficult concept for students. An object moving horizontally with a constant speed and then falling, however, can be considered as two one-dimensional problems, as illustrated in the diagram at right.

There are many investigations and problems that can be done by students assuming two, one-dimensional problems without involving vector components.

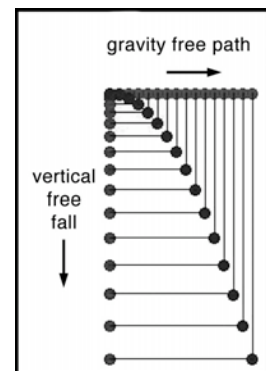

## OBJECTIVE 3.5

### MAGNETIC AND ELECTRICAL INTERACTIONS AND FORCES (Grades 5-8 and Grades 9-12)

*Students understand that both magnetic interactions and electrical interactions occur between mutually attracting or repelling objects, which can cause a change in motion. Electrical interactions apply to point charges and are governed by a force law.*

An *operational definition* uses real objects and real operations (not merely words) to produce, measure, or recognize an instance of the term [e.g., density, magnet]. In these standards, an object is a magnet if it stops swinging and orients in the geographical north-south direction when it is freely suspended (operational definition). Similarly, an object is charged if it attracts small pieces of paper or thin foil (operational definition). These operational definitions allow easy communication between scientists who might have different theories about magnets or charges, but they can agree that the objects ARE magnets or charges.

#### Table of Common Student Conceptual Difficulties, Grades 5-8 and Grades 9-12

Students' conceptual difficulties with magnetic and electrical forces persist through several years. This table shows the overlap between the middle school years and high school.



Student Difficulty.+ Students often believe that:	Where Addressed	
	Essential Knowledge	Learning Outcome
1. All metals are attracted to a magnet; all magnets are made of iron.	M.3.5.1	M.B.1
2. The magnetic pole of the Earth in the northern hemisphere is a north pole, and the pole in the southern hemisphere is a south pole.	M.3.5.1	M.B.1
3. A charged object can only affect other charged objects.	M.3.5.2b H.5.5.6	M.B.2 M.B.3 H.B.6
4. Atomic Model of Charges <ul style="list-style-type: none"> <li>a. A charged object has only one type of charge.</li> <li>b. Positively charged objects have gained protons, rather than being deficient in electrons.</li> <li>c. Electrons that are lost by an object are really lost (no conservation of charge).</li> </ul>	H.3.5.5	H.B.4
5. The electric force between two charged objects is not affected by the distance between them.	M.3.5.2c H.3.5.2	M.B.7 H.B.8
6. Coulomb's law applies to charge systems consisting of something other than point charges.	H.3.5.2 H.3.5.3	H.B.7
7. Equilibrium means that all the forces on an object are equal and opposite.	-----	H.B.9
8. Charges can disappear (are not conserved), especially in charging by induction.	H.3.5.4	H.B.1

+ See also conceptual difficulties in Objective 5.1 (Forces and Fields), Objective 5.3 (Electromagnetism and Fields), and Objective 3.2 (Forces and Changing Motion)

## Grades 5-8

### Table of Content Boundaries

<b>PHENOMENA, REPRESENTATIONS AND MODELS, AND TECHNICAL VOCABULARY</b>
<b>Middle School (Grades 5-8)</b>
<p><b>OBSERVATIONS/PHENOMENA (Real World)</b></p> <ul style="list-style-type: none"> <li>• One dimensional motion and force</li> <li>• <b>Events and Objects: Magnetism.</b> Simple, everyday events (other interactions negligible) involving the interaction of magnets of different shapes and strengths with other magnets and magnetic materials (e.g., objects made of different types of metal, household non-metallic objects, and so on).</li> <li>• <b>Events and Objects Electrostatics.</b> Simple, everyday events (other interactions negligible) involving the interaction of charged objects with other charged and uncharged objects (e.g., pieces of different types of cloth; pieces of hard plastic, rubber balloons, glass, Styrofoam, scotch tape; pieces of light metals like straws covered with aluminum foil, Christmas tinsel, and so on)</li> </ul> <p><i>Exclusions:</i> two and three dimensional motion and forces; charging by induction</p>
<p><b>REPRESENTATIONS/MODELS</b></p> <ul style="list-style-type: none"> <li>• Same as Objective 3.2</li> </ul> <p><i>Exclusions:</i> Charge measurement: Coulombs (C)</p>
<p><b>TECHNICAL VOCABULARY</b></p> <ul style="list-style-type: none"> <li>• magnetic interaction</li> <li>• electrical interaction</li> <li>• electrical conductor and insulator</li> </ul> <p><i>Exclusions:</i> Coulomb's Law, polarization</p>

Underlined words and phrases are defined in the Glossary.

### M.B.1 Experiment

Use painted bar magnets and painted long, rectangular or cylindrical bars made of steel, copper, tin, wood, plastic, and so on. Students suspend the painted objects to determine which objects align in the geographical north-south direction (the magnets).



### M.B.5 Experiment

A long piece of coat hanger and a thin wooden dowel, with Christmas tinsel attached to one end, make good detectors of whether charges move from one end of the material (touched by a charged object) to the other end with the tinsel. The metal coat hanger with tinsel is similar to the construction of an electroscope. For more ideas see Robert Morse's book, *Teaching About Electrostatics* (1992).

## Grades 9-12

### Table of Content Boundaries

PHENOMENA, REPRESENTATIONS AND MODELS, AND TECHNICAL VOCABULARY
High School (Grades 9-12)
<p><b>OBSERVATIONS/PHENOMENA</b> (Real World)</p> <ul style="list-style-type: none"> <li>Linear motion only; simple forces along direction of motion.</li> <li>Same events and objects as for grades 6-8, but can include more complicated situations and materials (e.g., light metallic spheres (or pop cans) attached to insulating bases, suspended pith balls, simple electroscopes, an electrophorus, and so on).</li> </ul> <p><i>Exclusions:</i> magnetic interactions, two- and three-dimensional motion and forces.</p>
<p><b>REPRESENTATIONS/MODELS</b></p> <ul style="list-style-type: none"> <li>Same as Objective 3.2.</li> <li>Diagrams of objects that can be marked with + and – signs for charges.</li> <li>Charge measurement: Coulombs (C), multiples of the charge of an electron.</li> </ul>
<p><b>TECHNICAL VOCABULARY</b></p> <ul style="list-style-type: none"> <li>Coulomb's Law</li> <li><u>charging by induction</u></li> </ul>

Underlined words and phrases are defined in the Glossary.

### H.B.7 Example Explanations

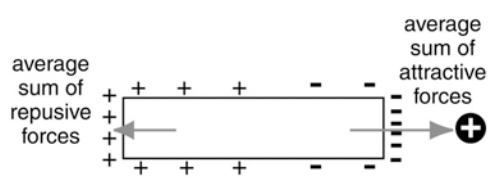

**External Charge Near a Conductor.** When a positively charged object is near a neutral metal conductor, the free electrons in the metal are attracted toward the object. According to Coulomb's law, the force between two charged objects decreases with increasing distance between charges. The excess positive charges are farther away from the external positive charge, so the sum of the repulsive forces on the positive charges is less than the sum of the attractive forces on the excess, negatively charged electrons. This results in a net attractive force between the external charge and the neutral conductor.

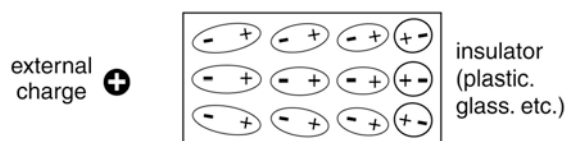

**External Charge Near an Insulator.** When a charged object is near a neutral insulator, the electron cloud of each insulator atom shifts position slightly so it is no longer centered on the nucleus. According to Coulomb's law, the force between two charged objects decreases with increasing distance between charges. The negative end of the atoms are closer to the positive external charge, so the average force on the positive end of each atom is less than the average force on the negative end, resulting in an attractive force between the external charge and each atom. The attractive force between the external charge and the whole insulator is the sum of the attractive force on all the atoms.



## INSTRUCTIONAL GUIDANCE FOR STANDARD 4. ENERGY TRANSFERS AND STORAGE

*Interactions of an object with other objects can be described and explained by using the concept of the transfer of energy from one object to another, both within a defined system and across the boundary of the system. Energy transfers across the boundary of a system can change the energy within the system. In the conservation of energy equation, one or more energy transfers across the system boundary or energy changes within the system could be applicable, not applicable, or too small of an effect to be measurable, depending on the problem situation.*

Energy is an abstract, mathematical idea that cannot be separated from the fundamental conservation of energy principle. An article by Robin Miller (2005) about teaching energy in middle school and high school concluded that:

“... energy is not a mechanism that explains how things happen. It does not help us to understand how or why they happen. When we introduce pupils [students] to energy ideas, *we are not providing them with an idea that is of immediate practical use.* Instead we are introducing them to a very general, overarching point of view that can be used to think about an enormously wide range of phenomena, across all the sciences. Energy provides an integrating framework. It can be intellectually satisfying to see diverse events from a single unifying perspective. It is a ‘neat idea’, rather than a practically useful one. Later, of course, it can become very useful for anyone who pursues science further. But it only really comes into its own when we can treat the ideas mathematically, and calculate amounts of energy in different situations.

These standards adhere to this view, which is consistent with the treatment of energy in the AP Physics B courses.

### OBJECTIVE 4.1

#### CONTACT INTERACTIONS AND ENERGY (Grades 5-8 and Grades 9-12)

*Students understand that a mechanical energy transfer (work) across the boundary of a system can change the kinetic energy, stored elastic energy, thermal energy, chemical energy, or other types of energy stored within the system.*

#### **Table of Common Student Conceptual Difficulties Grades 5-8 and Grades 9-12**

Students’ conceptual difficulties with energy persist through several years. This table shows the overlap between the middle school years and high school.

Student Difficulty <sup>+</sup> Students often believe that:	Where Addressed	
	Essential Knowledge	Learning Outcome
1. Energy is confined to a specific origin: a. Energy is found only in living things (or is what we get from food). b. Energy is associated only with movement or activity. c. Energy is only associated with fuels, or what we get from power stations.	All of the Essential Knowledge and Learning Outcomes in Objectives 4.1 through 4.5	
2. Energy is a “thing.” [This is a fuzzy notion, probably because of the way we talk about Newton-meters or joules. It is difficult to imagine an “amount” of an abstraction.]		
3. The terms “energy” and “force” are interchangeable.	M.4.1.2 H.4.1.2	M.B.2 M.B.3 H.B.3 H.B.4
4. Energies are always the same (mechanical, kinetic, thermal, etc) for all defined systems and time intervals.	H.4.1.3	H.B.2

Student Difficulty <sup>+</sup> Students often believe that:	Where Addressed	
	Essential Knowledge	Learning Outcome
5 There are no energy terms for transfer (energy in transit from one location to another) that are different from the energies that objects can have.	M.4.1.2 M.4.1.3 H.4.1.3	M.B.3  H.B.1
6. Work		
a. "Work" is synonymous with "labor". It is hard to convince someone that more work is probably being done playing football for one hour than studying an hour for a quiz.	M.4.1.2 H.4.1.2	M.B.2 H.B.2
b. A force acting on an object does work even if the object does not move.	M.4.1.2	M.B.2
c. "Work done on an object" and "work done by an object" does not transfer energy into or out of a system.	H.4.1.2 H.4.1.3	H.B.4
7. Doubling the speed of a moving object doubles its kinetic energy.	H.4.1.5	H.B.5

<sup>+</sup> See also conceptual difficulties in Objective 2.1 (Conservation of Mass, Energy, and Charge), and Objective 4.5 (Heating and Cooling Interactions and Energy

## Grades 5-8

### Table of Content Boundaries

<b>PHENOMENA, REPRESENTATIONS AND MODELS, AND TECHNICAL VOCABULARY</b>
<b>Middle School (Grades 5-8)</b>
<p><b>OBSERVATIONS/PHENOMENA</b> (Real World)</p> <ul style="list-style-type: none"> <li>• <b>Objects and Events.</b> Simple objects and events such as:                             <ul style="list-style-type: none"> <li>- Negligible friction and drag: humans, ropes, car with hitched trailer, pulling or pushing on another solid system with negligible friction or drag -- e.g., low-friction carts, puck-balloon system, a human-skateboard system, ice skater system, throwing a ball, kicking a soccer ball or batting a softball, etc.,</li> <li>- With friction and drag: books, boxes, or cars with brakes on, sliding over another surface and slowing down or being pushed or pulled and moving with a constant speed or speeding up; boat moving through water; big solid objects moving through air; wind moving solid objects</li> <li>- Springs and rubber bands pulling or pushing horizontally on another object and visa versa.</li> </ul> </li> </ul> <p><i>Exclusions:</i> vertical, projectile, or three-dimensional motion; elastic interactions between rigid bodies; at-rest situations (e.g., book sitting on the table); gravitational interactions; static friction interactions; interactions which require Newton's third law;</p>
<p><b>REPRESENTATIONS/MODELS</b></p> <ul style="list-style-type: none"> <li>• <u>Analogue model</u>: storage of energy in physical systems similar to storage of objects in containers</li> <li>• <u>Energy diagrams</u></li> </ul> <p><i>Exclusions:</i></p>
<p><b>TECHNICAL VOCABULARY</b></p> <ul style="list-style-type: none"> <li>• motion (kinetic) energy</li> <li>• mechanical energy transfer</li> <li>• chemical energy</li> <li>• elastic energy</li> <li>• thermal energy</li> </ul> <p><i>Exclusions:</i> The term "work" is not used (until grades 9-12) because of the conceptual difficulties students have understanding and using this term.</p>

Underlined words and phrases are defined in the Glossary.

### M.B.1 Example Diagram

See Instructional Guidance for Standard 1, Objective 1.1: energy diagram should be similar to the diagram students create to represent interactions and interaction chains. The diagram below is only one example.

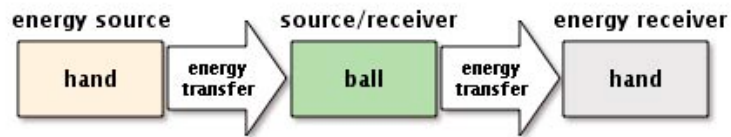

**Information About Friction in Wheeled Objects**

The rubbing wheel parts of a skateboard include the ball bearings and casings shown in this detailed diagram. The inner casing is attached to the axle and does not spin. The wheel is attached to the outer casing, which rolls over the ball bearings and allows the wheel to spin.

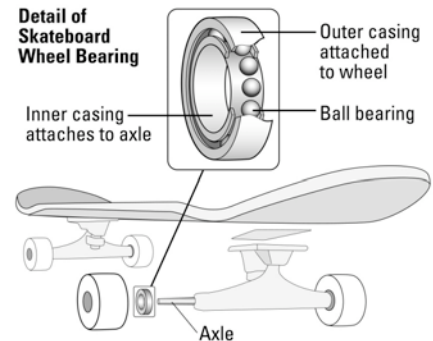

Other wheeled objects have a similar design.

**M.B.3 Example of Energy Diagrams**

Example 1. A boy pulls a sled and it speeds up. Draw an energy diagram that describes the applied interaction between the boy and the sled as the sled speeds up.

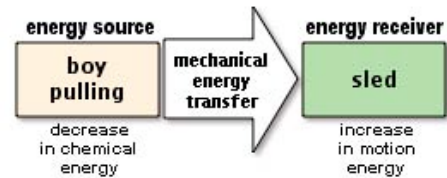

Example 2. A book slows down as it moves across the table, and the surface of the book and tabletop become a little warmer. Draw an energy diagram that describes the friction interaction as the book slows down.

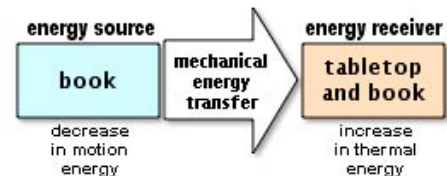

Example 3. A skateboard slows down on the smooth pavement and the rubbing wheel parts (wheel bearing) get a little warmer. Draw an energy diagram that describes the friction interaction between the skateboard and the rubbing wheel parts as the skateboard slows down.

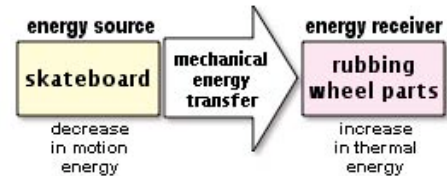

Example 4. After a boat’s motor is turned off, the boat slows down and the water speeds up. Draw an energy diagram that that describes the drag interaction between the boat and the water.

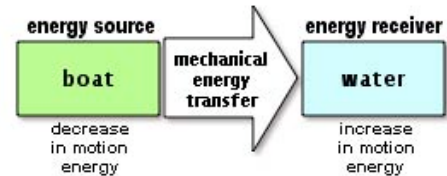

Example 5. An archer launches an arrow from the stretched string of her bow. The arrow speeds up and the string of the bow returns to its relaxed position. Draw an energy diagram that describes the elastic interaction between the stretched string of the bow and the arrow.

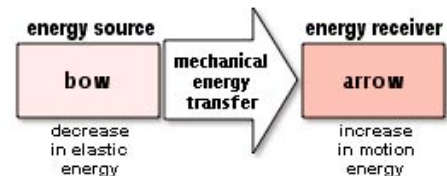

## Grades 9-12

### Table of Content Boundaries

PHENOMENA, REPRESENTATIONS AND MODELS, AND TECHNICAL VOCABULARY
High School (Grades 9-12)
<p><b>OBSERVATIONS/PHENOMENA</b> (Real World)</p> <ul style="list-style-type: none"> <li>• <b>Objects and Events.</b> Same as in middle school, but more complex situations.</li> </ul> <p><i>Exclusions:</i> vertical, projectile and three-dimensional motion and forces.</p>
<p><b>REPRESENTATIONS/MODELS</b></p> <ul style="list-style-type: none"> <li>• Energy principle for mechanical energy transfers (<math>W</math>) only:  <math display="block">\Delta E_{\text{kinetic}} + \Delta E_{\text{elastic}} + \Delta E_{\text{thermal}} + \Delta E_{\text{chemical}} + \Delta E_{\text{other}} = W_{\text{in}} - W_{\text{out}}</math> </li> <li>• Mathematical representation of kinetic energy (<math>E_{\text{kinetic}} = 1/2 mv^2</math>).</li> <li>• Mathematical representation of change in elastic energy (<math>\Delta E_{\text{elastic}} = 1/2 k\Delta x^2</math>).</li> </ul>
<p><b>TECHNICAL VOCABULARY</b></p> <ul style="list-style-type: none"> <li>• work (mechanical energy transfer)</li> </ul>

Underlined words and phrases are defined in the Glossary.

### H.B.1 Example Problems

Example #1. A compressed spring is released, pushing a box across the floor. *The defined system is the box, and the time interval is from the instant the spring is released to the instant the spring is in its relaxed position.*

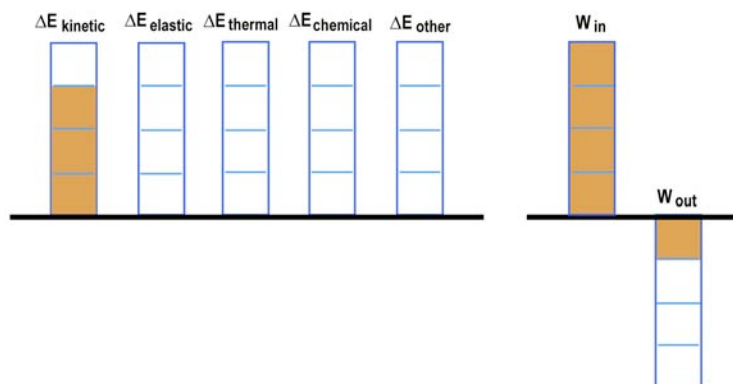

The conservation of energy equation for this situation is:

$$\Delta E_{\text{system}} = E_{\text{in}} - E_{\text{out}}$$

$$\Delta E_{\text{kinetic}} + \Delta E_{\text{elastic}} + \Delta E_{\text{thermal}} + \Delta E_{\text{chemical}} + \Delta E_{\text{other}} = W_{\text{in}} - W_{\text{out}}$$

The spring is not part of the defined system, so  $\Delta E_{\text{elastic}} = 0$ . Assume  $\Delta E_{\text{chemical}} = 0$ ,  $\Delta E_{\text{other}} = 0$ , and  $\Delta E_{\text{thermal}} = 0$  -- (i.e., assume these changes in energy are negligible compared to the mechanical energy transfer into the system, the mechanical energy transfer out of the system, and the increase in the kinetic energy of the box. The transfer of energy into the system (work done on the system) is the average force of the spring on the cart,  $\bar{F}_{\text{ave}}$ , times the distance the average force acts,  $\Delta x$  (i.e., the final position of the relaxed spring minus the initial position of the compressed spring). The average force is the average of  $k\Delta x$ , a constant spring force, and a zero spring force ( $\bar{F}_{\text{ave}} = 1/2 k\Delta x$ ). The transfer of energy out of the system (work done by the system) is the kinetic frictional force ( $f_k$ ) times the distance the frictional force acts ( $\Delta x$ ).

So

$$W_{\text{in}} = \bar{F}_{\text{ave}} \Delta x = \left( \frac{1}{2} k\Delta x \right) \Delta x = \frac{1}{2} k\Delta x^2, \text{ and } W_{\text{out}} = f_k \Delta x$$

$$\Delta E_{\text{kinetic}} = W_{\text{in}} - W_{\text{out}}$$

$$\frac{1}{2}mv^2 = \frac{1}{2}k\Delta x^2 - f_k\Delta x$$

Example #2. A compressed spring is released, pushing a box across the floor. *The defined system is the spring and box, and the time interval is from the instant the spring is released to the instant the spring is in its relaxed position.*<sup>1</sup>

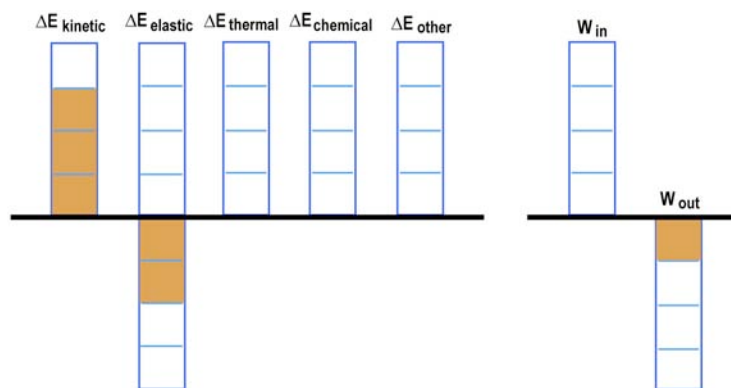

The conservation of energy equation for this situation is:

$$\Delta E_{\text{system}} = E_{\text{in}} - E_{\text{out}}$$

$$\Delta E_{\text{kinetic}} + \Delta E_{\text{elastic}} + \Delta E_{\text{thermal}} + \Delta E_{\text{chemical}} + \Delta E_{\text{other}} = W_{\text{in}} - W_{\text{out}}$$

In this situation, assume  $\Delta E_{\text{chemical}} = 0$ ,  $\Delta E_{\text{other}} = 0$ , and  $\Delta E_{\text{thermal}} = 0$  (i.e., these changes in energy are negligible compared to the decrease in the elastic energy of the spring and increase in the kinetic energy of the box). The external force is the frictional force on the box, so the transfer of energy out of the system (work done by the system) is  $W_{\text{out}} = f_k\Delta x$ , where  $\Delta x$  is the distance the frictional force acts (i.e., the final position of the relaxed spring minus the initial position of the compressed spring).

$$\Delta E_{\text{kinetic}} + \Delta E_{\text{elastic}} = -W_{\text{out}}$$

$$\frac{1}{2}mv^2 - \frac{1}{2}k\Delta x^2 = -f_k\Delta x$$

Notice that both examples must result in the same answer, since the conservation of energy principle holds for all types of interactions and all defined systems.

## OBJECTIVE 4.2

### ELECTRIC CIRCUIT INTERACTIONS AND ENERGY (Grades 5-8 and Grades 9-12)

*Students understand that the energy changes within the system depend on the properties of the electrical energy source and the electrical device(s) in the circuit. The electric charges that flow in the circuit are in the conductors of the circuit. A battery or other source moves electric charges through the circuit but does not create electric charges. An electrical energy transfer from the source of electric current to the electrical device(s) in a circuit can change the energy stored in the system. All electrical devices transfer energy out of the system.*

#### Table of Common Student Conceptual Difficulties Grades 5-8 and Grades 9-12

Students' conceptual difficulties with electric circuits and energy persist through several years. This table shows the overlap between the middle school years and high school.

<sup>1</sup> The energy diagram here is an example of a graph found in many research-based introductory physics materials (See van Heuvelen, 1999; Modeling Instruction In High School Physics Project, <http://modeling.asu.edu/Projects-Resources.html/>).

Student Difficulty. <sup>+</sup> Students often believe that:	Where Addressed	
	Essential Knowledge	Learning Outcome
1. "Electricity" is a vague term that refers to both whatever flows in a circuit (e.g., electric current, electrons) and to the flow of energy in a circuit.	M.4.2.1a M.4.2.2	M.B.6
2. Electric current is the flow of energy, which is "used up" by the electrical device: <ol style="list-style-type: none"> <li>Current flows out of both terminals of a battery (or both connections in an electrical outlet) and meets at the electrical device, producing light and heat.</li> <li>Current flows from a battery (or other source of electricity) to a light bulb (or other item that consumes electricity), but not from the light bulb to the battery.</li> <li>Current flows around a complete circuit, but objects like light bulbs use it up, so less current returns than leaves the source of the electricity.</li> </ol>	M.4.2.2 H.4.2.2	M.B.3 H.B.6 H.B.7
3. Alternative Model of a Circuit <ol style="list-style-type: none"> <li>All of the electrical current (or electrons that make up the current) comes from (or is contained in) the battery or generator.</li> </ol>	M.4.2.2b	M.B.3 M.B.4 H.B.2
<ol style="list-style-type: none"> <li>Wires are hollow like a water hose, and electric current (or electrons) move inside the hollow space.</li> </ol>	M.4.2.1a	
<ol style="list-style-type: none"> <li>The electric current (or electrons) from a battery is always the same, regardless of the number of electrical devices that are in a single loop (in series) or the number of loops connected to the battery (because how can the battery know what is hanging on it).</li> </ol>	M.4.2.1c H.4.2.3	
4. Electric current as the flow of electrons: <ol style="list-style-type: none"> <li>Electrons in wires jump from atom to atom during a current.</li> <li>The flowing electrons carry energy to the electric device(s), deposit the energy in the devices, and then flow back to the battery.</li> <li>The flowing electrons inside of wires move at the speed of light.</li> </ol>	H.4.2.1 H.4.2.3	H.B.1 H.B.2
5. Resistors <ol style="list-style-type: none"> <li>Resistors consume charge.</li> <li>Charges slow down as they go through a resistor.</li> </ol>	H.4.2.5	H.B.1 H.B.3
6. Potential Difference ("voltage") <ol style="list-style-type: none"> <li>Current is the same thing as voltage. Voltage flows through a circuit.</li> <li>Voltage is energy.</li> <li>The bigger the battery, the more voltage.</li> </ol>	H.4.2.4 H.4.2.6	H.B.3 H.B.4
7. Power and energy are the same thing.	H.4.2.6	H.B.6 H.B.7

<sup>+</sup> See also conceptual difficulties in Objective 3.5 (Magnetic and Electrical Interactions and Forces)

## Grades 5-8

### Table of Content Boundaries

PHENOMENA, REPRESENTATIONS AND MODELS, AND TECHNICAL VOCABULARY
Middle School (Grades 5-8)
<b>OBSERVATIONS/PHENOMENA</b> (Real World) <ul style="list-style-type: none"> <li><b>Objects.</b> Simple electric circuit materials, such as batteries, small solar cells, bulbs, small motors with attachable fan blades, small buzzers</li> <li><b>Events.</b> Simple series and parallel circuits</li> </ul> <i>Exclusions:</i> Combined series and parallel circuits
<b>REPRESENTATIONS/MODELS</b> <ul style="list-style-type: none"> <li>Analogue models of electric circuit</li> <li><u>Energy diagrams</u></li> </ul> <i>Exclusions:</i> Circuit diagrams
<b>TECHNICAL VOCABULARY</b> <ul style="list-style-type: none"> <li>circuit (open and closed)</li> </ul>



**PHENOMENA, REPRESENTATIONS AND MODELS, AND TECHNICAL VOCABULARY**

**Middle School** (Grades 5-8)

- series and parallel circuits
- electric current (flow of charges through the conductors)

*Exclusions:* Electric current as flow of electrons.

Underlined words and phrases are defined in the Glossary.

**M.B.1 Example Problem**

Which of the bulbs in the circuits at right will light? Justify your answer based on the path of conductors from one end of the battery, through the bulb filament, to the other end of the battery.



**M.B.2 Mental Models of Electric Current**

As shown in the Table of Common Student Conceptual Difficulties, many students equate electric current or “electricity” with energy that is used up by the bulb. Three common alternative models are: (a) Current flows out of both terminals of a battery and meets at the electrical device, producing light and heat; (b) Current flows from a battery to a light bulb where it is used up, so there is no current from the light bulb to the battery; and (c) Current flows around a complete circuit, but the light bulbs use some of it, so less current returns than leaves the battery.

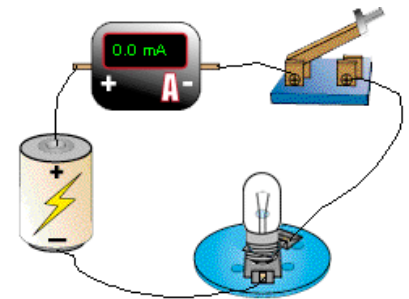

**M.B.4 Analogue Models of Circuits**

Research indicates that many analogue models are more confusing than helpful. Middle-school students may have severe difficulties understanding the hydraulic analogue of an electric circuit and think the two circuits belong to entirely different areas of reality (AAAS Benchmarks Online, Chapter 15). There is some indication that an analogy of the battery to your heart is helpful; your heart moves (pumps) blood through your body, but does not create blood; similarly, a battery moves (pumps) electric charge through the circuit, but does not create electric charges.

**M.B.5 Example Problems**

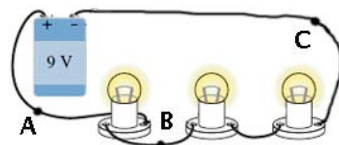

**Circuit I**

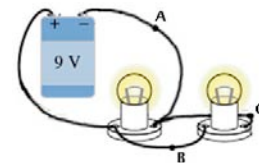

**Circuit II**

- Compare the magnitude of the current at points A, B, and C in Circuit I. Justify your answer.
- Compare the magnitude of the current at points A, B, and C in Circuit II. Justify your answer.

**Grades 9-12**

**Table of Content Boundaries**

**PHENOMENA, REPRESENTATIONS AND MODELS, AND TECHNICAL VOCABULARY**

**High School** (Grades 9-12)

**OBSERVATIONS/PHENOMENA** (Real World)

- **Objects.** Include batteries, bulbs, ammeter/voltmeter, resistors, small motors, small buzzer

**PHENOMENA, REPRESENTATIONS AND MODELS, AND TECHNICAL VOCABULARY**
**High School (Grades 9-12)**

- **Events.** Simple series circuits

*Exclusions:* parallel circuits

**REPRESENTATIONS/MODELS**

- For a series loop, the conservation of energy equation is:  $q\Delta V_1 + q\Delta V_2 + q\Delta V_3 + \dots = q\Delta V_{\text{battery}}$
- Power (energy per unit time) for a series circuit is  $I\Delta V_1 + I\Delta V_2 + I\Delta V_3 + \dots = P_{\text{battery}}$

**TECHNICAL VOCABULARY**

- potential difference (energy per unit charge) measured in volts ( $\Delta V = \Delta E/q$ )
- electric current (Coulombs per second) measured in amperes (A)

*Exclusions:* If possible, avoid “voltage” for potential energy difference and “electrons or charges as “energy carriers.”

Underlined words and phrases are defined in the Glossary.

**H.B.4 Analogue Models of Energy Potential Difference**

Research indicates that many analogue models are more confusing than helpful – for example charges as “energy carriers” implies that the charges somehow deposit their energy at the electrical device. The figure at right shows a mechanical equivalent to potential energy difference in a one-device circuit. The motor and conveyer belt on the left is the energy source (battery), the tubes are the conducting wires, the gear is the electrical device, and the balls are the moving charges. As the balls are lifted, the gravitational potential energy of the balls-rest of circuit system increases, and some thermal energy is transferred to the surroundings (dissipated). The balls then roll through a tube, with only a tiny decrease in the potential energy of the balls-rest of circuit system, in the same manner that current flows with very little loss of energy through conducting wires. Next, the balls drop from the tube onto the gear. In the process, gravitational potential energy decreases and the kinetic energy of the gear increases (Mazur, 2005).

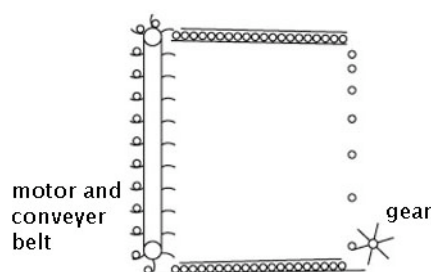
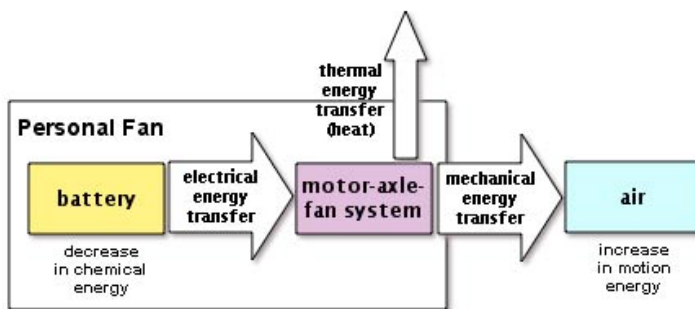
**H.4.2.5 Example Problem**

For a small, battery-operated personal fan and a short interval after fan has been running awhile, the temperature of the motor and casing has stopped changing. The conservation of energy equation is:

$$\Delta E_{\text{system}} = E_{\text{in}} - E_{\text{out}}$$

$$\Delta E_{\text{chemical}} = -(W_{\text{out}} + Q)$$

If the thermal energy transfer ( $Q$ ) is very small compared to the mechanical energy transfer out of the system, and can be ignored, then

$$\Delta E_{\text{chemical}} = -W_{\text{out}}$$

If the motor circuit can be considered resistive, then  $\Delta E_{\text{chemical}} = -q\Delta V_{\text{battery}}$ , so

$$q\Delta V_{\text{battery}} = W_{\text{out}}$$

In terms of power (energy per unit time),  $P_{\text{electrical}} = \frac{q\Delta V_{\text{battery}}}{\Delta t} = I\Delta V_{\text{battery}}$ , and  $P_{\text{mechanical}} = \frac{W_{\text{out}}}{\Delta t}$

$$\text{So } I\Delta V_{\text{battery}} = \frac{W_{\text{out}}}{\Delta t}$$

Of course, no motor is 100% efficient, nor is the circuit linearly resistive.

### OBJECTIVE 4.3

#### MECHANICAL WAVE INTERACTIONS AND ENERGY (Grades 5-8 and Grades 9-12)

*Students understand that a mechanical wave from a vibrating source transfers energy through a material to surrounding objects without a transfer of material. Interaction of a mechanical wave with different objects can cause the path of the wave to change. Energy changes within the receiver object depend on the properties of the object.*

#### Table of Common Student Conceptual Difficulties Grades 5-8 and Grades 9-12

Students' conceptual difficulties with energy and waves persist through several years. This table shows the overlap between the middle school years and high school.

Student Difficulty. Students often believe that:	Where Addressed	
	Essential Knowledge	Learning Outcome
1. Mechanical Waves		
a. Waves transport matter; matter moves along with water waves as the waves move through a body of water.	M.4.3.1	M.B.1
b. Waves do not have energy.	M.4.3.1; M.4.3.1c H.4.3.2	M.B.6 H.B.7
c. A wave's amplitude affects its speed. Big waves travel faster than small waves in the same medium.	M.4.3.1d	M.B.1; M.B.5
d. All waves are transverse waves – sound, surface water waves, and light.	M.4.3.1b	M.B.3
2. Sound and Pitch		
a. Sounds can travel through empty space (a vacuum); sounds cannot travel through liquids and solids.	M.4.4.1a M.4.4.2	M.B.2 M.B.4 M.B.6
b. Pitch is related to intensity; pitch is the same as loudness; hitting an object harder changes the pitch of the sound produced.	M.4.3.2	
c. The pitch of a tuning fork will change as it "slows down", (i.e. "runs" out of energy)	M.4.3.1d M.4.3.2	
3. Doppler Effect. The pitch of whistles or sirens on moving vehicles is changed by the driver as the vehicle passes.	H.4.3.4	H.B.6
4. Reflection, Refraction, Diffraction, and Interference		
a. When waves interact with a solid surface, the waves are destroyed	H.4.3.1a	H.B.1 H.B.2
b. Refraction does not change the frequency or wavelength of the wave.	H.4.3.1b	
c. Waves bend around corners, but they don't bend around solid barriers or openings in barriers.	H.4.3.1c	
d. Double-slit interference shows wave crest and troughs.	H.4.3.3	H.B.1; H.B.2; H.B.3
5. When two pulses, traveling in opposite directions along a spring or rope, meet, they bounce off each other and go back in the opposite direction.	H.4.3.3	H.B.3; H.B.4

## Grades 5-8

### Table of Content Boundaries

PHENOMENA, REPRESENTATIONS AND MODELS, AND TECHNICAL VOCABULARY
Middle School (Grades 5-8)
<p><b>OBSERVATIONS/PHENOMENA</b> (Real World)</p> <ul style="list-style-type: none"> <li>• <b>Objects and Events.</b> Waves on a Slinky, long stiff springs, or stretched cord; waves on the surface of water, sound.</li> </ul> <p><i>Exclusions:</i> refraction, diffraction, and interference.</p>
<p><b>REPRESENTATIONS/MODELS</b></p> <ul style="list-style-type: none"> <li>• Visual representations, animations, and simulations of waves on strings, a Slinky, surface water waves, sound waves</li> <li>• mathematical representation of wave speed in a uniform material, <math>v_{\text{wave}} = \text{constant} = \lambda f</math>.</li> </ul>
<p><b>TECHNICAL VOCABULARY</b></p> <ul style="list-style-type: none"> <li>• <u>transverse waves</u> and <u>compression (longitudinal) waves</u></li> <li>• <u>frequency</u>, <u>wavelength</u>, and <u>amplitude</u> of waves</li> <li>• wave speed</li> </ul>

Underlined words and phrases are defined in the Glossary.

### M.B.3 Example Problems

Example #1. You move a stretched spring up and down with your hand. The other end of the spring is attached to a string loop. The string loop is over a pole (so the spring and string loop can move up and down). The system is your hand and the spring.

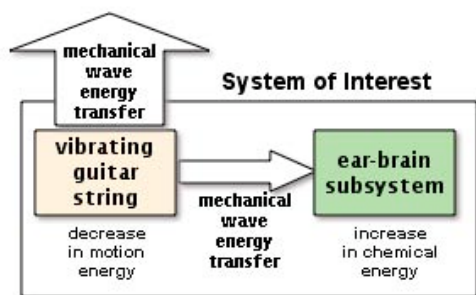
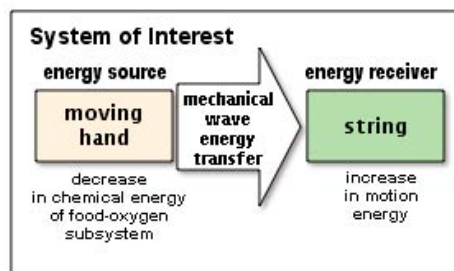

Example #2. You hear the sound of a plucked guitar string. The system is the guitar string and your ear-brain subsystem.

### M.B.6 Exploration

Watching the string in Example #1 above (or holding the loop end of the string) can provide qualitative evidence that the magnitude of the mechanical wave energy transfer in a fixed time interval increases with increasing frequency and amplitude of the wave.

## Grades 9-12

### Table of Content Boundaries

**PHENOMENA, REPRESENTATIONS AND MODELS, AND TECHNICAL VOCABULARY****High School** (Grades 9-12)**OBSERVATIONS/PHENOMENA** (Real World)

- **Objects and Events.** Include a ripple tank and/or other demonstration/class equipment that illustrate mechanical wave reflection, refraction, diffraction, interference, standing waves, and beats (sound). Some simulations may be substituted.
- **H.B.2.** Solid boundaries and variables should include solid barriers of different sizes, the interface between two materials, a solid barrier with a single slit of different sizes, a solid barrier with two slits of different sizes, and different distances between the slits.

**REPRESENTATIONS/MODELS**

- Visual representations, animations, and simulations of reflection, refraction, diffraction, and interference of mechanical waves.
- Conservation of energy equation for mechanical waves in a system consisting of two materials:

$$E_{\text{incident}} - E_{\text{reflected}} - E_{\text{transmitted}} = E_{\text{dissipated}}$$

- Energy diagrams

**TECHNICAL VOCABULARY**

- incident, reflected and transmitted radiant energy

Underlined words and phrases are defined in the Glossary.

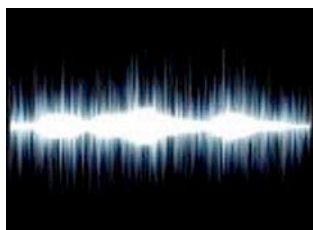
**H.B.1, H.B.2, and H.B.3**

(a)

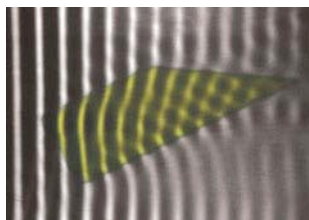

(b)



(c)



(d)

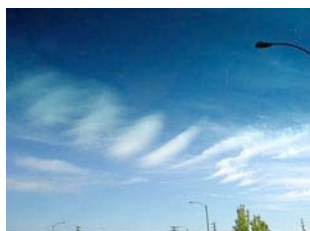

(e)



(f)

Students should be able to recognize, explain, and sketch the wave phenomena shown above (beats, refraction, two-source interference, Doppler effect, standing waves, and single-slit diffraction, respectively).

**OBJECTIVE 4.4****RADIANT ENERGY INTERACTIONS** (Grades 5-8 and Grades 9-12)

*Students understand that radiant energy from a source can be transferred to surrounding objects without a material (medium), and there are two models that illustrate how this happens. The energy changes within a receiver object depend on the properties of the object. There is a continuous range of radiant energies, which includes visible light. Humans can only perceive visible light energy — either from a source or that which is reflected off objects — when the light interacts with the eye-brain system.*

### Table of Common Student Conceptual Difficulties Grades 5-5 and Grades 9-12

Students' conceptual difficulties with light and color and the models of light persist through several years. This table shows the overlap between the middle school years and high school.

Student Difficulty. <sup>+</sup> Students often believe that:	Where Addressed	
	Essential Knowledge	Learning Outcome
1. Nature of Light		
a. Light is associated only with a source and/or its instantaneous effects. Light is not considered to exist independently in space. Light is not conceived as moving from one point to another with a finite speed. We see because we look, it has nothing to do with light.	M.4.4.1 M.4.4.2c	M.B.3 M.B.4
b. An object is seen whenever light shines on it, with no recognition that light must move between the object and the observer's eye.		
c. Light travels from the eyes to the object.	M.4.4.2	M.B.3
d. Light is not necessary to see since we can see a little in a dark room.		
2. Ray Diagrams. Lines drawn outward from a light bulb in a sketch represent the "glow" surrounding the bulb. Light from a bulb only extends outward a certain distance and then stops. How far it extends depends on the brightness of the bulb.		
3. Light interactions at barriers and interfaces between two materials:		
a. Light is reflected away from shiny surfaces, but light is not reflected from other surfaces (no diffuse reflection).	M.4.4.2b	M.B.3
b. Light reflects from a shiny surface in an arbitrary manner.	M.4.4.2b	M.B.3
c. Light always passes straight through transparent material (without changing direction).	H.4.4.1	H.B.3 H.B.4
d. Double slit interference shows light wave crests and troughs.	H.4.4.1	H.B.3
4. Color		
a. Color is a property of an object, and color is not affected by the eye-brain system or other receiving systems.		
b. White light is colorless and clear, enabling you to see the "true" color of an object.		
c. Sunlight is different from other sources of light because it contains no color.	M.4.4.2d M.4.4.2e	M.B.4 H.B.1
d. A white light source, such as an incandescent or fluorescent bulb, produces light made up of only one color.		
e. When white light passes through a prism, color is added to the light.		
6. Light is not energy because it does not "do work on" objects.	M.4.4.1 H.4.4.2	M.B.1; M.B.2 H.B.3
7. Gamma rays, X-rays, ultraviolet light, visible light, infrared light, microwaves, and radio waves are all very different entities.	H.4.4.4	H.B.2
9. The speed of light never changes (from special relativity).	H.4.4.7	H.B.3; H.B.4
10. Light is a mixture of particles and waves.	M.4.4.3 H.4.4.6	M.B.5 H.B.4
11. History of particle-like and wave-like models of light:		
a. History has no place in science.		
b. The null result in the Michelson-Morley experiment means that it was a failure.		
c. The ether exists because something must transmit light.	H.4.4.6	H.B.4

<sup>+</sup> See also conceptual difficulties in Objective 1.3.

## Grades 5-8

### Table of Content Boundaries

PHENOMENA, REPRESENTATIONS AND MODELS, AND TECHNICAL VOCABULARY
Middle School (Grades 5-8)
<b>OBSERVATIONS/PHENOMENA</b> (Real World)
<ul style="list-style-type: none"> <li><b>Objects.</b> Opaque objects with smooth, shiny or rough surfaces, diffraction grating or prism, light sources (long filament bulbs in</li> </ul>

**PHENOMENA, REPRESENTATIONS AND MODELS, AND TECHNICAL VOCABULARY****Middle School** (Grades 5-8)

porcelain sockets work well), high quality constrictor paper of different colors

- **Events.** Light and seeing; interaction of light with opaque objects.

*Exclusions:* Investigating refraction, diffraction, and interference of light

**REPRESENTATIONS/MODELS**

- Light ray diagrams (light source to eye-brain subsystem; light source to object to eye-brain subsystem).
- Pictures, animations, or computer simulations of the diffraction and interference of light.
- Energy diagrams.
- Particle-like and wave-like analogue models of light propagation.

**TECHNICAL VOCABULARY**

- ray diagram
- diffuse reflection:

Underlined words and phrases are defined in the Glossary.

**M.B.1 Examples<sup>2</sup>**

The demonstration/experiment works best in a darkened room, using flashlights or straight filament bulbs. Students have difficulty observing and understanding diffuse reflection. A physical model of a rough surface is a crumpled piece of aluminum foil that has been unfolded. The foil reflects enough light in different directions to be clearly seen on the white card. The experiments should also include the observation of the greater temperature change of dark objects (e.g., holding white and black pieces of construction paper near a straight-filament light bulb).

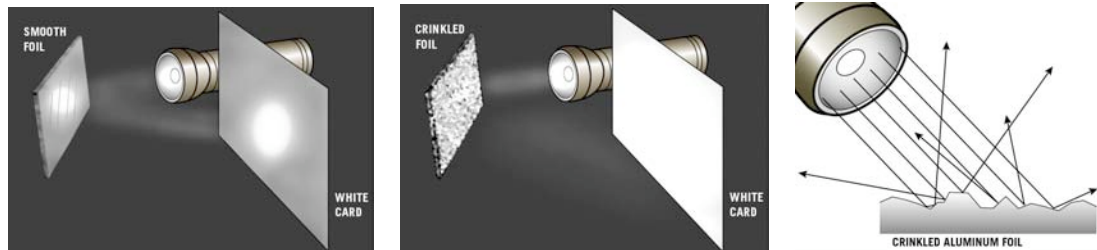
**M.B.3 and M.B.4 Example Problem**

Example #1. A girl is sitting outdoors at a picnic table. Explain, using words and diagrams, how the girl sees an apple on the picnic table

Light is hitting the apple from all directions. Light from the sun hits many locations on the apple and bounces off in all directions from each location (diffuse reflection). Some of this reflected light reaches the girl's eyes. Light reflected from the table hits many locations on the apple and bounces off in all directions from each location. Some of this reflected light reaches the girl's eyes. All the light reflected off the apple that reaches her eyes goes into her eye-brain system and she sees the apple.

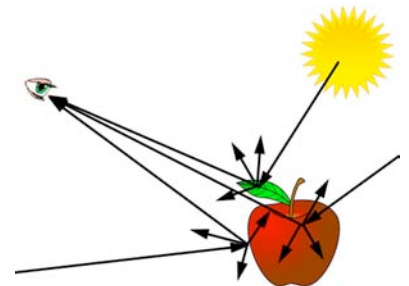

Example #2. Explain, using words and a ray diagram, why the girl in the drawing sees the lemon in the tree as yellow. [Drawings for these problems are not shown.]

Example #3. Explain, using words and a ray diagram, how the boy in the drawing can see the orange in the tree.

Example #4. Explain, using words and a ray diagram, why the girl in the drawing can see the squirrel when they are both standing in the shadow of a tree.

<sup>2</sup> Goldberg, Bendall, Heller, and Poel, 2006.



Example #5. Explain, using words and a ray diagram, how the boy in the drawing can see the book on the table when no lights are on in the room and no sunlight is shining through the one window in the room.

## Grades 9-12

### Table of Content Boundaries

PHENOMENA, REPRESENTATIONS AND MODELS, AND TECHNICAL VOCABULARY
High School (Grades 9-12)
<p><b>OBSERVATIONS/PHENOMENA</b> (Real World)</p> <ul style="list-style-type: none"> <li>• <b>Objects.</b> Diffraction gratings, light sources, demonstration or computer simulation of two-slit interference.</li> <li>• <b>Events.</b> Reflection, refraction, diffraction, and interference of light energy.</li> <li>• <b>H.B.4.</b> Boundaries should include the interface between two materials (including the case of a transparent boundary like water), a solid boundary with a single slit of different sizes, and a solid boundary with two slits of different sizes and different distances between the slits.</li> </ul>
<p><b>REPRESENTATIONS/MODELS</b></p> <ul style="list-style-type: none"> <li>• Particle-like and wave-like <u>analogue models</u> of light propagation.</li> <li>• Mathematical representation of conservation of energy for system consisting of two materials (e.g., air and water):  <math display="block">E_{\text{incident}} - E_{\text{reflected}} = E_{\text{material}} = E_{\text{absorbed}} + E_{\text{transmitted}}</math> </li> <li>• Visual representations, animations, and computer simulations of refraction, diffraction, and interference of light.</li> </ul>

### Objects and Phenomena

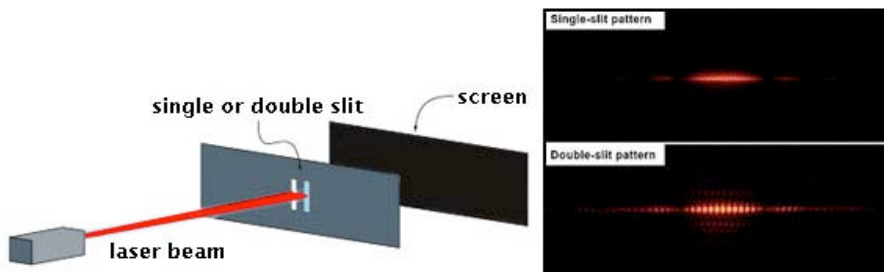
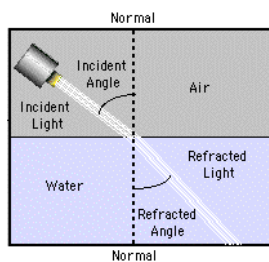

Students should recognize and be able to sketch light refraction, diffraction, and two-slit interference.

### H.B.1 Evidence That Prism Does Not Create the Colors of Light

For example, Newton demonstrated that the colors from a prism could be mixed together to form white light. He also demonstrated that if one color of light from a prism is then passed through an identical prism, no new colors are produced. Red remains red and is refracted the same amount; blue remains blue and is refracted by the same amount.

### H.B.2 Electromagnetic Spectrum

In the wave model, radiant energy is directly proportional to “frequency” and inversely proportional to wavelength. Students find energy versus wavelength diagrams and graphs confusing because of the inverse relationship. The electromagnetic spectrum (with seven energy bands) should be labeled with energy (joules) and/or frequencies, NOT with wavelengths. See example on next page



**H.B.3 Example Problem**

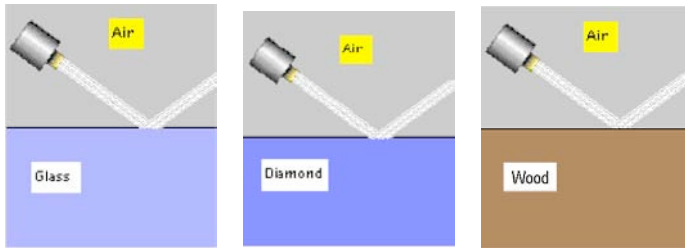

Instead of water, suppose a beam of light was incident on smooth glass and smooth diamond, which are more dense optically than water, or on a smooth, opaque object like wood. What happens to the energy of the reflected light?

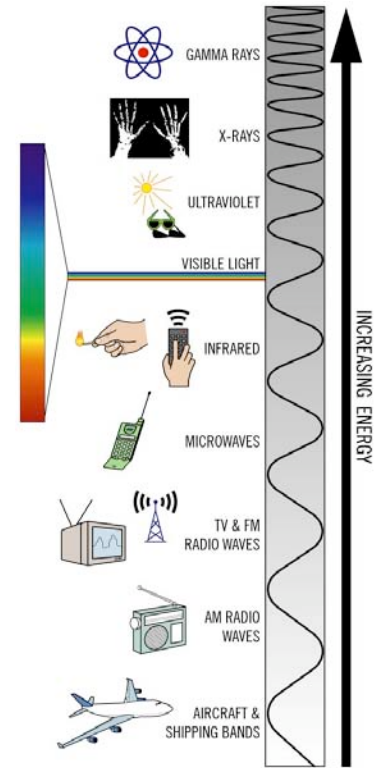

$$E_{\text{incident}} - E_{\text{reflected}} = E_{\text{material}}$$

The more optically dense the material, the more energy is reflected by the material (at the extreme of a smooth, opaque object, most of the energy is reflected). So the energy of the reflected light increases from water to glass to diamond to wood.



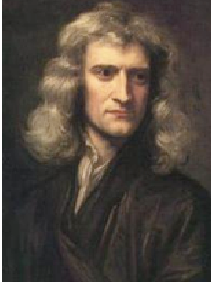

**H.B.4 History of the Wave and Particle Models of Light\***

(a) Explain how Isaac Newton (particle model) and Christian Huygens (wave model) answered the following questions: Why does light travel in straight lines? Why can light travel through a vacuum? Why is the angle of incidence equal to the angle of reflection? When light goes from air into glass or water, why does light bend toward the perpendicular to the surface? Why does a prism separate a beam of white light into the colors of the rainbow? Why does red light refract least and violet light refract most?

	 <p><b>Isaac Newton</b> (1643-1727) proposed that light is a stream of tiny particles, called <i>Corpuscles</i>.</p>	 <p><b>Christian Huygens</b> (1629-1695) proposed that light is emitted as a series of waves in a medium called the "ether."</p>
<p>Why can light travel through a vacuum?</p>	<p>Light, being particles, can naturally pass through vacuum. (At Newton's time, no known wave could travel through a vacuum.)</p>	<p>In the 17<sup>th</sup> century, it was believed that waves required a medium and could not travel through a vacuum, which was why Huygens invented the "ether" for light propagation.</p>

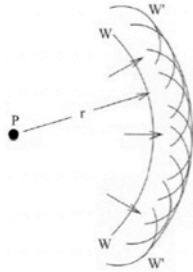
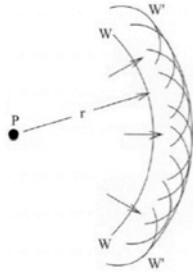
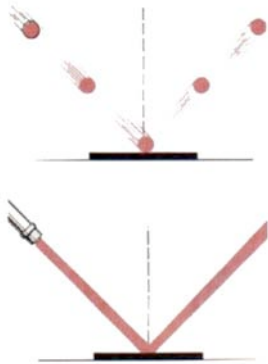
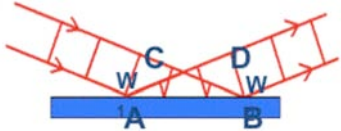
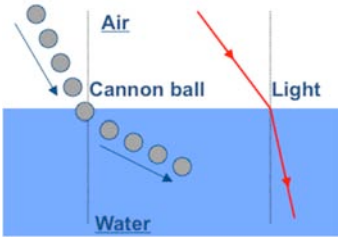
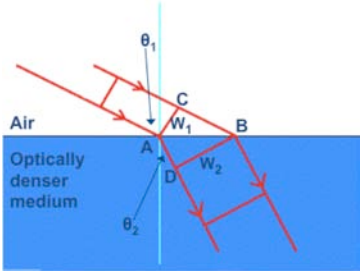
\* Images and some information from [http://learningscience.edu.hku.hk/Files/Light\\_P\(E\).ppt](http://learningscience.edu.hku.hk/Files/Light_P(E).ppt).

<p>Why does light travel in straight lines?</p> <p><i>Nobody could measure the diffraction and interference of light at the time of Newton and Huygens.</i></p> 	<p>A ball thrown into space follows a curved path because of gravity. Yet if the ball is thrown with greater and greater speed, its path curves less and less. Thus, billions of tiny light particles of extremely low mass traveling at enormous speeds will have paths which are essentially straight lines.</p>	 <p>Huygens proposed a wavelet theory of wave propagation. A wave starts at P and "wavefront" W moves outwards in all directions. After a time, t, it has a radius r. Each point on the wavefront starts a secondary wavelet. These secondary wavelets interfere to form a new wavefront W' at time t'. So waves travel in straight lines from a point at the origin outward in all directions.</p> <p><b>The Problem:</b> Waves can also bend around corners (e.g., sound).</p>
<p>How does the particle theory explain the Laws of Reflection?</p>	<p>The rebounding of a steel ball from a smooth plate is similar to the reflection of light from the surface of a mirror</p> 	<p>When wavefront W<sub>1</sub> (AC) reaches point A, a secondary wave from A starts to spread out. When the incoming wavefront reaches B, the secondary wave from A has reached D, giving a new wavefront W<sub>2</sub> (BD). Angle of incidence = Angle of reflection can be proved by geometry.</p> 
<p>How does the particle theory explain the Laws of Refraction?</p> <p><i>Nobody could measure the speed of light at the time of Newton and Huygens.</i></p>	<p>A cannon ball hits the surface of water and is acted upon by a "refracting" force that is perpendicular to the water surface. It therefore slows down and bends away from the normal. Light does the opposite. Newton explained this observation by assuming that light travels faster in water, so it bends towards the normal.</p>  <p><b>The Prediction:</b> Light travels faster in water.</p>	<p>As wavefront W<sub>1</sub> reaches the boundary between media 1 &amp; 2, point A of wavefront W<sub>1</sub> starts to spread out. When the incoming wavefront reaches B, the secondary wave from A has travelled a shorter distance to reach D. It starts a new wavefront W<sub>2</sub>. As a result the wave path bends towards the normal.</p>  <p><b>The Prediction:</b> Light travels slower in water.</p>
<p>Why does light have different colors?</p>	<p>The particles of different colors have different properties, such as mass, size and speed.</p>	<p>Huygens could not explain why light has different colors. He did not know that different colors of light can be associated with different "frequencies."</p>

<p>Why does a prism separate a beam of white light into the colors of the rainbow? Why does red light refract least and violet light refract most?</p>	<p>Newton's assumptions:</p> <ol style="list-style-type: none"> <li>1. The light particles of different colors have mass. Red light particles have more mass than violet particles.</li> <li>2. All light particles experience the same refracting force when crossing an interface.</li> </ol> <p>Thus, red light particles with more mass will be refracted less by the same force than violet light particles by the same force.</p>	 <p>The wave model could not explain why a prism separates white light into different colors.</p>
--	---	--

- b) Explain why, for the next hundred years, most scientists believed that Newton's particle model had the greater explanatory power.
- c) Explain why the experiments of Thomas Young (1803) and Hippolte Fizeau (1851) led scientists to accept the wave model of light.

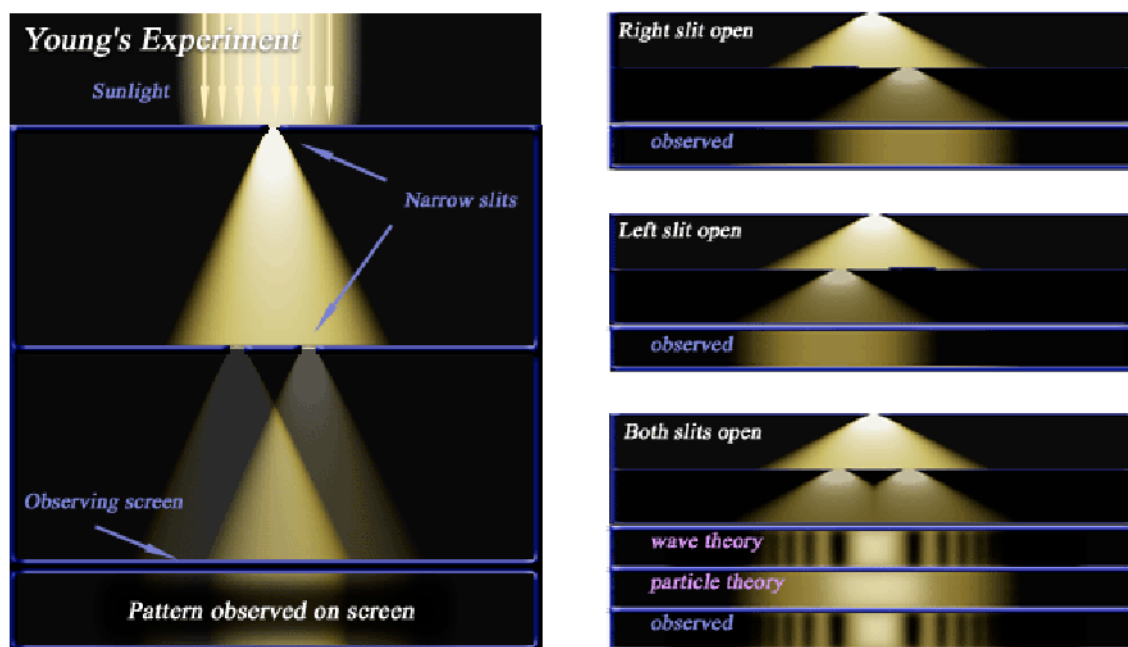

In 1803, Thomas Young's experiment showed that when sunlight passes through two slits, an interference pattern results, which cannot be explained with Newton's particle model. In 1851, Hippolte Fizeau's experiment showed that the speed of light in water is less than the speed of light in air. This experiment put the seal of approval on the wave model of light propagation and the existence of the ether.♦

- (d) Give examples of experiments in the early 20th century that revived the particle model of light (e.g., the Michelson-Morley experiment, the photoelectric effect).

See Instructional Guidance for Standard 1, Objective 1.3 for an explanation the supporting evidence of the particle model of the photoelectric effect. See Instructional Guidance for Standard 1, Objective 1.4 for a description of the Michelson-Morley experiment, which found no evidence for the ether.

♦ Image of Thomas Young's experiment from <http://www.illuminatingscience.org/2006/10/>

**OBJECTIVE 4.5****HEATING AND COOLING INTERACTIONS AND ENERGY (Grades 5-8 and Grades 9-12)**

*Students understand that a thermal energy transfer (heat) from one object to another can change the thermal energies of the objects. The interactions depend on the properties of the materials and on how far the system is from equilibrium. There are three different methods of thermal energy transfer: conduction, convection, and thermal radiation. At a constant temperature in any time interval, the amount of thermal radiation emitted by an object to its surroundings is equal to the amount of thermal radiation absorbed by the object from its surroundings in that same time interval (thermal equilibrium).*

**Table of Common Student Conceptual Difficulties Grades 5-8 and Grades 9-12**

Students' conceptual difficulties with heat energy persist through several years. This table shows the overlap between the middle school years and high school.

Student Difficulty. <sup>+</sup> Students often believe that:	Where Addressed	
	Essential Knowledge	Learning Outcome
1. Heat is a substance; heat is not energy.	M.4.5.1	M.B.4
2. Heat (transfer of thermal energy) is the same as the energy possessed by an object (internal or thermal energy).	M.4.5.1 M.4.5.2 H.4.5.6	M.B.4 H.B.7
3. Temperature		
a. Thermal energy and temperature are the same.	M.4.5.2a M.4.5.4a	M.B.1
b. Temperature is a property of a particular material or object (e.g., metal is naturally colder than plastic).	M.4.5.4 H.4.5.4	H.B.3a
c. The temperature of an object depends on its size.	M.4.5.2b H.4.5.1	M.B.1 H.B.1
4. Objects with different temperatures, which are either in constant contact with each other or in contact with air at a different temperature, do not necessarily move toward the same temperature.	M.4.5.2a	M.B.2
5. Conduction and Convection		
a. Objects that readily become warm (conductors of heat) do not readily become cold.		
b. Heat and cold are different, rather than being opposite ends of continuum. Heat and cold flow like liquids. Cold can be transferred.	M.4.5.2a M.4.5.4c	M.B.3 M.B.4
c. Heat only travels upward.		
6. Expansion and Contraction		
a. All solids expand at the same rate.		
b. All substances (including water) expand when heated.	M.4.5.3d M.4.5.4B	M.B.5 M.B.6
c. Expansion of matter is due to expansion of particles rather than to increased particle speed and particle spacing.		
7. Thermal Conductivity		
a. Thermal conductivity is the maximum amount of heat a substance can conduct.		
b. Skin is a good thermometer.	H.4.5.3	H.B.2 H.B.3a H.B.3b
c. Sweaters will make you warmer.		
8. Specific Heat Capacity		
a. Specific heat capacity is the same as the thermal energy of a substance.		
b. (Specific) heat capacity is the maximum amount of heat (thermal energy) that a substance can have.	H.4.5.1	H.B.1
9. Thermal Equilibrium		
a. Thermal equilibrium is equivalent to the steady flow of heat.		
b. Objects at the same temperature are not necessarily in thermal equilibrium.	H.4.5.4 H.4.5.5	H.B.3d
10. Change of State (melting and freezing)		
a. When temperature at boiling or freezing remains constant, something is "wrong". Temperature should change since thermal energy is being added or removed		
b. Ice cannot change temperature.	H.4.5.2	H.B.7
c. The temperature of an object drops when it freezes.		
d. Melting/freezing and boiling/condensation are often understood only in terms of water.		

Student Difficulty. <sup>†</sup> Students often believe that:	Where Addressed	
	Essential Knowledge	Learning Outcome
e. At the atomic scale, the constant temperature during melting and boiling can be explained by increased energy “overcoming” the attractive forces between the particles of the solid or liquid.		

† See also P.2.1 for conceptual difficulties with the conservation of energy principle.

## Grades 5-8

### Table of Content Boundaries

PHENOMENA, REPRESENTATIONS AND MODELS, AND TECHNICAL VOCABULARY
<b>Middle School</b> (Grades 5-8)
<b>OBSERVATIONS/PHENOMENA</b> (Real World) <ul style="list-style-type: none"> <li>• <b>Objects and Events.</b> Hot and cold water, thermometers, long metal rods, metal cubes, candles, and other equipment or demonstration materials for convection, conduction, and radiant thermal energy transfers.</li> </ul>
<b>REPRESENTATIONS/MODELS</b> <ul style="list-style-type: none"> <li>• <u>Energy diagrams</u></li> <li>• Visual representations, animations, or computer simulations of convection, conduction, and radiant thermal energy transfers (including infrared photograph).</li> </ul>
<b>TECHNICAL VOCABULARY</b> <ul style="list-style-type: none"> <li>• thermal energy transfer (heat)</li> <li>• conduction, convection, and radiant thermal energy transfers</li> </ul>

Underlined words and phrases are defined in the Glossary.

### M.B.4 Example Energy Diagrams

Example 1. Your hand is held next to, but not touching, a cup of hot chocolate. The system is the cup of hot chocolate and your hand.

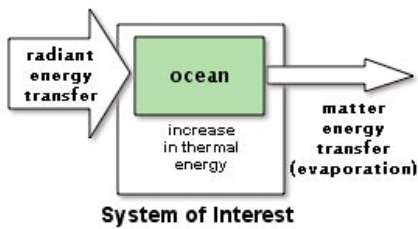
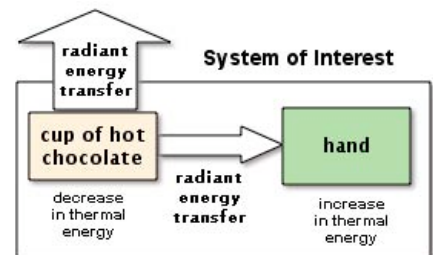

Example 2. The sun warms the ocean. The defined system is the ocean.

Example 3. You hold your hand about 18 inches above a small candle. The defined system is the candle and your hand.

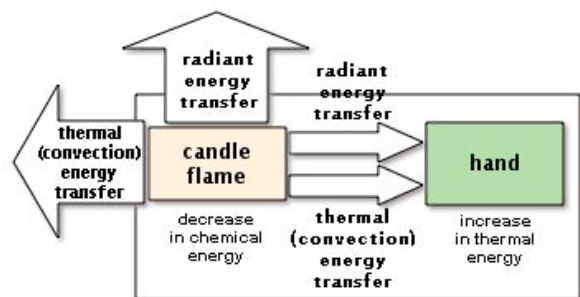

## Grades 9-12

### Table of Content Boundaries

PHENOMENA, REPRESENTATIONS AND MODELS, AND TECHNICAL VOCABULARY
High School (Grades 9-12)
<p><b>OBSERVATIONS/PHENOMENA</b> (Real World)</p> <ul style="list-style-type: none"> <li>• <b>Objects and Events.</b> Same as for middle school. Additional events include heating and cooling solids, water, and air, boiling water, and freezing water. See also Suggested Experiments or Demonstrations below.</li> </ul> <p><i>Exclusions.</i> Heating or cooling other liquids than water.</p>
<p><b>REPRESENTATIONS/MODELS</b></p> <ul style="list-style-type: none"> <li>• Mathematical representation of the conservation of energy for special situations in which the only transfers of energy into and/or out of a system are thermal energy transfers (heat) and/or mechanical energy transfers (work), and the only change of energy within a system is an increase or decrease of thermal energy:</li> </ul> $\Delta E_{\text{system}} = E_{\text{in}} - E_{\text{out}}$ $\Delta E_{\text{thermal}} = (Q_{\text{in}} - Q_{\text{out}}) + (W_{\text{in}} - W_{\text{out}})$ <ul style="list-style-type: none"> <li>• Visual representations, animations, and computer simulations of the specific heat of different materials and thermal conductivity.</li> </ul>
<p><b>TECHNICAL VOCABULARY</b></p> <ul style="list-style-type: none"> <li>• transfer of thermal energy (heat)</li> <li>• specific heat</li> <li>• thermal conductivity</li> </ul>

Underlined words and phrases are defined in the Glossary.

### Suggested Experiments or Demonstrations

- Heating and/or cooling different masses of the same material by the same method for the same time interval [H.B.1]
- Heating one end of different materials of approximately the same shape and length by the same method for the same time interval [to establish a relative scale of thermal conductivities from good insulators to good conductors; metals are good conductors. [H.B.2]
- Students touch objects in the room (metals, wood, plastics, rugs or blankets, etc) to determine if they feel like they are at the same temperature or different temperatures. [H.B.3]
- Heating and/or cooling the same mass of different substances by the same method for the same time interval to establish the difference between thermal energy transfer (heat), thermal energy, and temperature. [H.4.5.3]
- Hold different flat objects (e.g., rough and smooth dark and light colored paper of different sizes) close to a heat source (e.g., long filament bulb) for the same time interval. [H.4.5.5]

### H.B.7 Example Problems

Example #1. The air in a closed pump is compressed quickly by pushing on the piston with an average force,  $F_{\text{ave}}$ , for a distance  $\Delta x$ . The system is the air in the pump.

The conservation of energy equation for this situation is:

$$\Delta E_{\text{system}} = E_{\text{in}} - E_{\text{out}}$$

$$\Delta E_{\text{thermal}} = (Q_{\text{in}} - Q_{\text{out}}) + (W_{\text{in}} - W_{\text{out}})$$

$$\Delta E_{\text{thermal}} = W_{\text{in}} = F_{\text{ave}} \Delta x$$

Example #2. A Styrofoam cup of hot tea is left in the room until it reaches room temperature. The system is the tea in the cup.

The conservation of energy equation for this situation is:

$$\Delta E_{\text{system}} = E_{\text{in}} - E_{\text{out}}$$

$$\Delta E_{\text{thermal}} = (Q_{\text{in}} - Q_{\text{out}}) + (W_{\text{in}} - W_{\text{out}})$$

There is no transfer of mechanical energy into or out of the system, and assume that the transfer of thermal energy out of the Styrofoam cup is negligible. The change in the thermal energy of the tea is  $c_t m_t (T_{\text{room}} - T_{\text{initial}})$ , where  $c_t$  is the specific heat of tea,  $m_t$  is the mass of the tea,  $T_{\text{room}}$  is the temperature of the room, and  $T_{\text{initial}}$  is the initial temperature of the tea.

$$\Delta E_{\text{thermal}} = -Q_{\text{out}}$$

$$c_t m_t (T_{\text{room}} - T_{\text{initial}}) = -Q_{\text{out}}$$

**Example #3.** Cool water from the tap is poured into an electric tea kettle and heated. The system is the water, and the time interval is from just after the water is heated to just before the water boils (100°C).

The conservation of energy equation for this situations is

$$\Delta E_{\text{system}} = E_{\text{in}} - E_{\text{out}}$$

$$\Delta E_{\text{thermal}} = (Q_{\text{in}} - Q_{\text{out}}) + (W_{\text{in}} - W_{\text{out}})$$

There is no transfer of mechanical energy into or out of the system, and assume that the transfer of thermal energy out of the electric tea kettle is negligible. The change in the thermal energy of the water is  $c_w m_w (T_{\text{final}} - T_{\text{initial}})$ , where  $c_w$  is the specific heat of water,  $m_w$  is the mass of the water,  $T_{\text{final}}$  is the final temperature of the water (100°C), and  $T_{\text{initial}}$  is the initial temperature of the cool water from the tap.

$$\Delta E_{\text{thermal}} = Q_{\text{in}}$$

$$c_w m_w (T_{\text{final}} - T_{\text{initial}}) = Q_{\text{in}}$$





## INSTRUCTIONAL GUIDANCE FOR STANDARD 5. FORCES, ENERGY AND FIELDS

*Attractive and repulsive interactions at a distance (e.g., gravitational, magnetic, electrical and electromagnetic) can be described and explained using a field model. The field model explains how objects exert attractive and repulsive forces on each other at a distance, and where energy is stored in the system.*

### OBJECTIVE 5.1 FORCES AND FIELDS (Grades 5-8 and Grades 9-12)

*Students understand that the field model explains how objects exert attractive and repulsive forces on each other at a distance: their fields are the agents of the interaction.*

#### **Table of Common Student Conceptual Difficulties Grades 5-8 and Grades 9-12**

Students' conceptual difficulties with fields persist through several years. This table shows the overlap between the middle school years and high school.

Student Difficulty. † Students often believe that:	Where Addressed	
	Essential Knowledge	Performance Expectation
1. Field lines are real. Field lines can begin/end anywhere. There are a finite number of field lines. If a charge or compass is not on a field line, it feels no force.	Field lines are not introduced; field diagrams are used instead.	
2. All forces have to be contact forces.	M.5.1.1	M.B.1
3. Fields don't exist unless there is something to detect them.	M.5.1.1 H.5.1.1	M.B.6 H.B.6
4. Forces at a point exist without a compass, mass, or charge there.	M.5.1.3	M.B.2 M.B.4
5. A field and a force are the same thing and in the same direction.	M.5.3.1a M.5.1.3b	M.B.3 M.B.5
6. a. Magnetic fields are the same as electric fields. b. The electric force is the same as the gravitational force.	H.5.1.2 H.5.1.3	H.B.3 H.B.4 H.B.5
7. Fields are not 3-dimensional.	M.5.1	H.B.5

† See also conceptual difficulties for Objective 3.4 (Gravitational Interaction and Forces) and Objective 3.5 (Magnetic and Electric Interactions and Forces).

### Grades 5-8

#### **Table of Content Boundaries**

PHENOMENA, REPRESENTATIONS AND MODELS, AND TECHNICAL VOCABULARY Middle School (Grades 5-8)
<p><b>OBSERVATIONS/PHENOMENA</b> (Real World)</p> <ul style="list-style-type: none"> <li>• Objects. Long springs, cords, strips of rubber sheeting (see first comment below); large, strong bar and horseshoe magnets; several small compasses and a few good compasses; spring scale with unit mass and a plumb line.</li> <li>• Events/Phenomena. Magnetic and gravitational interaction, interaction between two wooden balls with attached spring.</li> </ul> <p><i>Exclusions:</i> Interaction between two magnets or two planets.</p>

**PHENOMENA, REPRESENTATIONS AND MODELS, AND TECHNICAL VOCABULARY**

**Middle School** (Grades 5-8)

**REPRESENTATIONS/MODELS**

- Magnetic field diagrams
- Gravitational field diagrams
- Animations and computer simulations of field diagrams

*Exclusions:* Vector **field line** diagrams are excluded; field diagrams are limited to one magnet or planet.

**TECHNICAL VOCABULARY**

- magnetic field model
- gravitational field model

*Exclusions:* *Electrical field model* (introduced in grades 9-12)

Underlined words and phrases are defined in the Glossary.

**M.B.1 Investigating and Inventing the Field Model**

J. Myron Atkin and Robert Karplus (1962) described how to introduce 2nd-grade students to the ideas of direct interactions and interactions-at-a-distance, and the field model of magnetic interactions. A brief summary, with language appropriate to middle-school, is given below.

Experiment #1: Two students pull in a rope in opposite directions. The interactions are student 1 ↔ rope and rope ↔ student 2. While the two students are interacting, it is not a direct interaction but an “interaction-at-a-distance.” The rope made the interaction possible.

Experiment #2. Show two wooden balls held together by a strip of rubber tacked to the balls. Students identify system is the two balls, the rubber strip, and two thumbtacks. The direct interactions are ball 1 ↔ thumbtack 1, thumbtack 1 ↔ rubber sheet, rubber sheet ↔ thumbtack 2, and thumbtack 2 ↔ ball 2. The interaction-at-a-distance is ball-ball. The force of one ball on the other ball is weak when the balls are close together, and stronger when the balls are farther apart. *The rubber sheet makes the interaction-at-a-distance possible.*

Experiment #3. Repeat Experiment 2 with a long spring. The interaction-at-a-distance is the ball-ball. The spring makes the interaction-at-a-distance possible.

Experiment #4. Attach horseshoe magnets to two low-friction carts, mounted to attract each other. The interaction-at-a-distance is the magnet-magnet interaction. The magnetic force decreases with increasing distance between the magnets. Ask: Is there something now between the two magnets that make the interaction-at-a-distance possible? Students explore interaction of two magnets (at a fixed distance apart) with other objects (e.g., small compass, steel nail suspended on a string). Even though invisible, there is evidence of something between the two magnets that make the interaction-at-a-distance possible. This “something” is called the magnetic field.

Of course, there are other instructional strategies for introducing the idea of a magnetic field to students.

**Examples of Magnetic Field Diagrams**

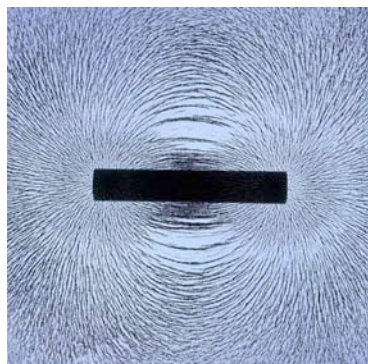
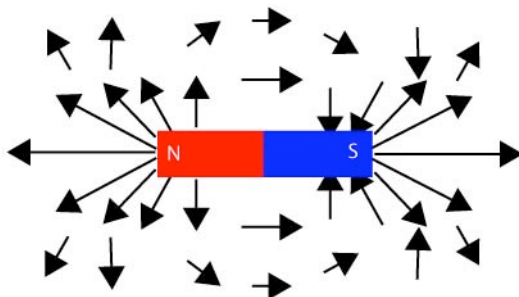

It is impossible to avoid iron-filings photos of magnetic fields. Students should know that the iron filings only show the direction of the magnetic field, not the magnitude of the magnetic forces

**Examples of Gravitational Field Diagrams**

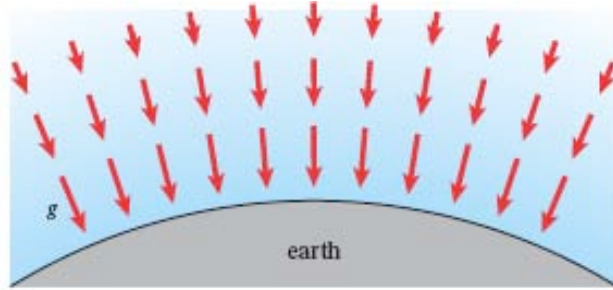

Grades 9-12

**Table of Content Boundaries**

PHENOMENA, REPRESENTATIONS AND MODELS, AND TECHNICAL VOCABULARY
High School (Grades 9-12)
<p><b>OBSERVATIONS/PHENOMENA</b> (Real World)</p> <ul style="list-style-type: none"> <li>Different planets and moons (gravitational field strength), different magnitudes of point charges, dipoles, two large capacitor plates with uniform charge distributions, large sheet with uniform charge distribution.</li> </ul> <p><i>Exclusions:</i> More complex charge distributions.</p>
<p><b>REPRESENTATIONS/MODELS</b></p> <ul style="list-style-type: none"> <li>Analogies to other quantities that have a values at each point in space (e.g., temperature, pressure)</li> <li>Gravitational and electrical <u>field diagrams</u></li> </ul> <p><i>Exclusions:</i> Field line diagrams are excluded. Magnetic and electromagnetic interactions excluded.</p>
<p><b>TECHNICAL VOCABULARY</b></p> <ul style="list-style-type: none"> <li>electric field strength, <math>E = F_e/q</math>.</li> <li>gravitational field strength (intensity); <math>g = F_g/m</math>.</li> </ul>

**H.B.5 Examples of Electric Field Diagrams**

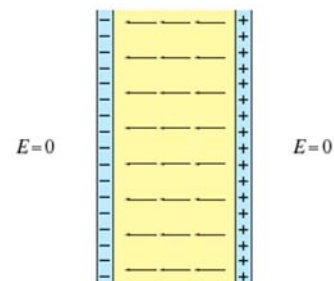
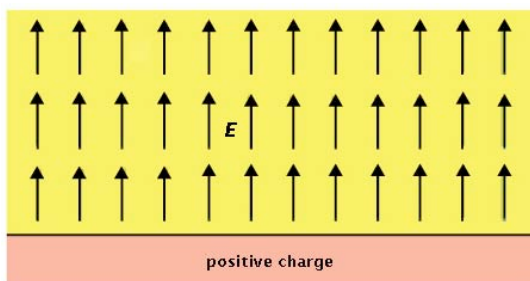
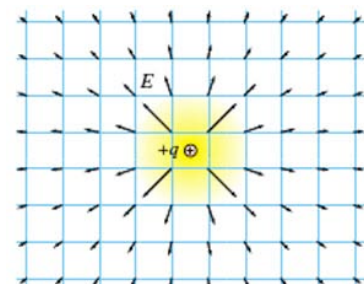
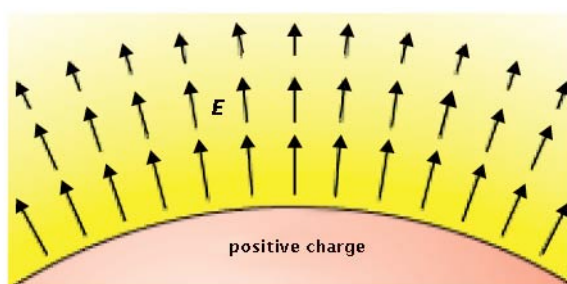

Electrical field of large uniformly charged sheet.

Electrical field of a charged capacitor.

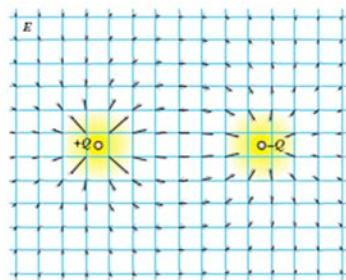

Electrical field of a dipole.

**H.B.1. Table of the Gravitational Field Strength on the Surface of Planets and Moon.**

	Mercury	Venus	Earth	Moon	Mars	Jupiter	Saturn	Uranus	Neptune	Pluto
$g$ (N/kg)	3.76	8.89	9.81	1.63	3.70	2.31	8.98	8.72	10.98	0.58

Example Problem(s).

- Calculate your weight on Earth in Newtons.
- On which planet would you weigh the least? The most? Explain your reasoning.
- Calculate your weight on these two planets.
- Would your weight be larger on the moon or on Pluto? Explain your reasoning.
- Calculate your weight on the Moon.

**OBJECTIVE 5.2****ENERGY AND FIELDS** (Grades 5-8 and Grades 9-12)

*Students understand that the field model explains where the energy is stored in a system of two mutually attracting or repelling objects -- in the field of the system. Only systems (not single objects) can have field (potential) energies. Energy can be transferred to and from the field of the system.*

**Table of Common Student Conceptual Difficulties Grades 5-8 and Grades 9-12**

Students' conceptual difficulties with potential energy persist through several years. This table shows the overlap between the middle school years and high school.

Student Difficulty. <sup>+</sup> Students often believe that:	Where Addressed	
	Essential Knowledge	Learning Outcome
1. The only type of potential energy is gravitational.	M.5.2.2 H.5.2.4	M.B.3 M.B.4
2. Potential energy is not energy. It becomes energy when it is transferred.	M.5.2.2 H.5.2.4	M.B.2 M.B.4
3. Gravitational Potential Energy <ol style="list-style-type: none"> <li>Gravitational potential energy depends only on the height of an object.</li> <li>When an object is released to fall, the gravitational potential energy immediately becomes all kinetic energy.</li> </ol>	H.5.2.3	H.B.1 H.B.2

Student Difficulty. <sup>†</sup> Students often believe that:	Where Addressed	
	Essential Knowledge	Learning Outcome
4. Single Objects Have Potential Energy <ul style="list-style-type: none"> <li>a. An object has to stop in order to have potential energy.</li> <li>b. The potential energy that an object has before it starts moving is more than its kinetic energy at the final stage of motion.</li> <li>c. Objects always have potential energy. Potential energy is a thing that objects hold (like cereal stored in a closet).</li> </ul>	M.5.2.1 H.5.2.4	M.B.1 H.B.4 H.B.5
5. "Voltage" <ul style="list-style-type: none"> <li>a. There is no connection between "voltage" and electric field.</li> <li>b. Voltage is energy</li> </ul>	H.5.2.5	H.B.5

<sup>†</sup> See also conceptual difficulties for Objective 3.4 (Gravitational Interaction and Forces) and Objective 3.5 (Magnetic and Electrical Interactions and Forces)

## Grades 5-8

### Table of Content Boundaries

PHENOMENA, REPRESENTATIONS AND MODELS, AND TECHNICAL VOCABULARY
Middle School (Grades 5-8)
<p><b>OBSERVATIONS/PHENOMENA</b> (Real World)</p> <ul style="list-style-type: none"> <li>• <b>Events and Objects.</b> Dropping and lifting small objects, stretching and compressing springs or stretching rubber bands.</li> </ul> <p><i>Exclusions:</i> Electric charge fields.</p>
<p><b>REPRESENTATIONS/MODELS</b></p> <ul style="list-style-type: none"> <li>• <u>Analogue model</u> of stretching and compressing a spring to increasing or decreasing magnetic field energy.</li> <li>• Analogue model of stretching a spring to increasing gravitational field energy.</li> </ul>
<p><b>TECHNICAL VOCABULARY</b></p> <ul style="list-style-type: none"> <li>• magnetic field energy</li> <li>• gravitational field energy</li> </ul> <p><i>Exclusions:</i> The phrase "potential energy" is not introduced until grades 9-12.</p>

Underlined words and phrases are defined in the Glossary.

### M.B.2. and M.B.3 Suggested Experiment

Use books or blocks to support a *smooth* wood or Plexiglas board. Sprinkle iron filings thinly over the board. Hold two strong repelling magnets, far apart, under the board. Observe the pattern of iron filings. Slowly move the repelling magnets closer together and observe what happens to the iron filings. Repeat the procedure for separating repelling magnets, separating attracting magnets, and moving attracting magnets closer together.

### M.B.3 Suggested Animations

PhET Interactive Simulations, University of Colorado, Boulder (<http://phet.colorado.edu/index.php>) has produced three animations that help students visualize magnetic fields and how electromagnets and generators work: *Magnet and Compass*, *Magnets and Electromagnets*, and *Generators*.

### M.B.4 Example Response

**Question.** Predict how the gravitational field energy changes (a) when an object is moved at a constant speed from the ground to a height  $h$  above the ground, and (b) when the object is released and falls to the ground.

**Example Response.** When an object is lifted, to a height  $h$ , the gravitational field increases, similar to storing energy by stretching a spring. When the object is released and falls toward the ground, the gravitational field energy decreases, similar to releasing a stretched spring. The energy appears as an increase in the motion (kinetic) energy of the object.

## Grades 9-12

### Table of Content Boundaries

PHENOMENA, REPRESENTATIONS AND MODELS, AND TECHNICAL VOCABULARY
High School (Grades 9-12)
<p><b>OBSERVATIONS/PHENOMENA</b> (Real World)</p> <ul style="list-style-type: none"> <li>• <b>Events and Objects.</b> Similar to middle school, but with the addition of different methods of separating charges.</li> </ul> <p><i>Exclusions:</i> Electromagnetic interactions are excluded.</p>
<p><b>REPRESENTATIONS/MODELS</b></p> <ul style="list-style-type: none"> <li>• <u>Energy diagrams</u></li> <li>• Mathematical representation of the conservation of energy for systems that include magnetic, gravitational or electric field potential energies. For situations in which the only transfers of energy are mechanical energy transfers (<i>work</i>), and with the system defined as the two magnets, the Earth and the object, or the two charged objects, then <math>\Delta E_{\text{kinetic}} + \Delta E_{\text{elastic}} + \Delta E_{\text{thermal}} + \Delta E_{\text{chemical}} + \Delta PE_{\text{field}} = W_{\text{in}} - W_{\text{out}}</math></li> <li>• Visual representations, animations, and computer simulations of different methods of separating charges (e.g., battery, van de Graaff machine, charging two materials by friction then separating two materials, capacitor)</li> </ul>
<p><b>TECHNICAL VOCABULARY</b></p> <ul style="list-style-type: none"> <li>• potential energy</li> <li>• gravitational (field) potential energy</li> <li>• electric (field) potential energy</li> </ul>

Underlined words and phrases are defined in the Glossary.

### H.B.3 Example Problem

You hold together two repelling magnets, the defined system, close together on a table. You release the magnets and they each slide a distance  $\Delta x$  across the table before coming to a stop. The time interval is from the instant you release the magnets to the instant the magnets come to a stop.

The conservation of energy equation is:

$$\Delta E_{\text{system}} = E_{\text{in}} - E_{\text{out}}$$

$$\Delta PE_{\text{magnets}} = W_{\text{in}} - W_{\text{out}}$$

$$\Delta PE_{\text{magnets}} = -2f_k \Delta x$$

The decrease the magnetic field energy of the magnets is equal to the transfer of mechanical energy (work) out the system to the table and air (friction and drag). The changes in thermal energy of the system (due to friction) and the transfer of mechanical energy to the air are assumed to be negligible.

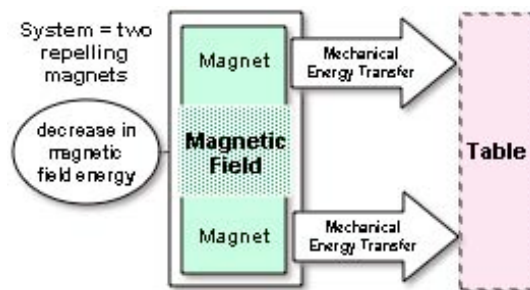

### H.B.4 Example Problem

A ball is dropped from a height  $h$  above the floor. The time interval is just after the ball is released to just before it hits the floor.



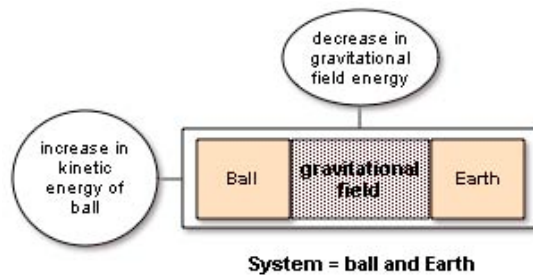

The conservation of energy equation for the Earth-ball system is.

$$\Delta E_{\text{system}} = E_{\text{in}} - E_{\text{out}}$$

$$\Delta E_{\text{kinetic}} + \Delta PE_{\text{grav field}} = W_{\text{in}} - W_{\text{out}}$$

$$1/2mv^2 - mgh = -W_{\text{out}}$$

$$1/2mv^2 = mgh - W_{\text{out}}$$

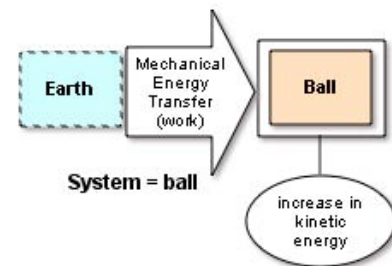

The conservation of energy equation for the ball system is.

$$\Delta E_{\text{system}} = E_{\text{in}} - E_{\text{out}}$$

$$\Delta E_{\text{kinetic}} = W_{\text{in}} - W_{\text{out}}$$

$$1/2mv^2 = F_{\text{ext}}h - W_{\text{out}}$$

$$= mgh - W_{\text{out}}$$

For objects that do not fall too far or too fast through the atmosphere, the mechanical energy transfer out of the system to the air (work done on the air) is very small and can be neglected.

### H.B.5 Example Problem

You rub together a piece of fur and a rubber rod, the defined system, then slowly move the fur and rod apart at a constant speed with an average force  $F$ . The time interval is from just as you start rubbing the fur and rubber rod together to just as you have separated the fur and rubber rod a distance  $\Delta x$ .

The conservation of energy equation is:

$$\Delta E_{\text{system}} = E_{\text{in}} - E_{\text{out}}$$

$$\Delta PE_{\text{electric field}} + \Delta E_{\text{thermal}} = W_{\text{in}}$$

$$\Delta PE_{\text{electric field}} + \Delta E_{\text{thermal}} = F_{\text{ext}}\Delta x$$

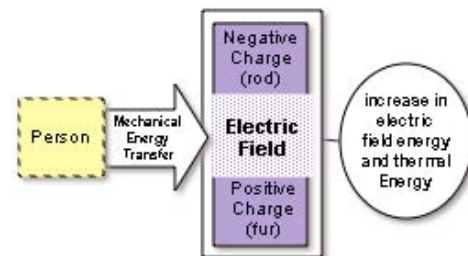

### H.B.5 Other Methods of Separating Charges

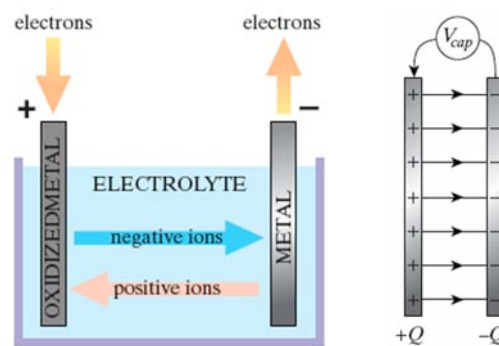

In a van de Graaff machine, a nonconducting conveyer belt carries charges to a hollow conducting dome that rests on a nonconducting support.

In a battery, two conducting terminals are submerged in a solution containing mobile ions. A chemical reaction with the ions at one terminal deposits electrons, while the chemical reaction at the other terminal detaches an electron from the terminal.

A capacitor consists of two conducting plates, separated by a nonconductor. When connected to a battery, the capacitor acquires opposite charges on each plate, which can be stored for a long time.

### H.B.9 Suggested Animations

PhET Interactive Simulations, University of Colorado, Boulder (<http://phet.colorado.edu/index.php>), has several useful simulations, including: *Electric Field of Dreams* and *Electric Field Hockey*.

Ruth Chabay has also produced many animations of what happens to the electric field of a system of charged particles in different circumstances (<http://www4.ncsu.edu/~rwchabay/emimovies/>. Chabay, R. and Sherwood, B., *Electric and Magnetic Interactions*, (Wiley, New York, 1995). For example, the four pictures below show what happens to the electric field when two attracting charged particles are released and move closer together.

These interactive computer simulations and animations can help students visualize that the energy stored in the field around the two charged objects decreases as they move closer together.

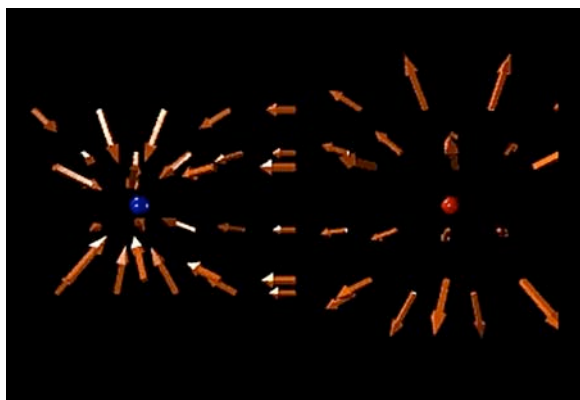

(a)

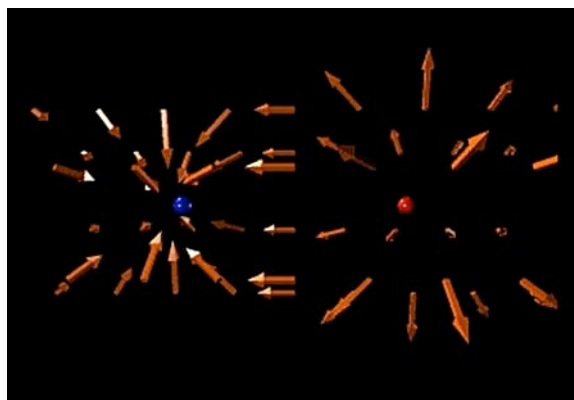

(b)

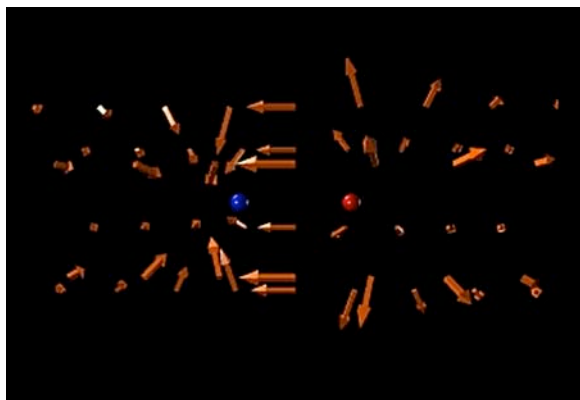

(c)

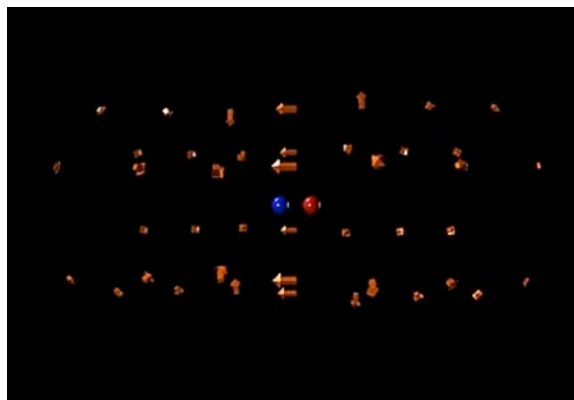

(d)

## OBJECTIVE 5.3

### ELECTROMAGNETISM AND FIELDS (Grades 5-8 and Grades 9-12)

*Students understand that an electromagnetic interaction occurs when a flow of charged particles creates a magnetic field around the moving particles, or when a changing magnetic field creates an electric field.*

#### Table of Common Student Conceptual Difficulties Grades 5-8 and Grades 9-12



Students' conceptual difficulties with electromagnetism persist through several years. This table shows the overlap between the middle school years and high school.

Student Difficulty. <sup>+</sup> Students often believe that:	Where Addressed	
	Essential Knowledge	Learning Outcome
1. Connection Between Current Electricity and Magnetism <ol style="list-style-type: none"> <li>Charges, when released, will move toward the poles of a magnet.</li> <li>North and south magnetic poles are the same as positive and negative charges.</li> <li>Magnetic poles can be isolated.</li> <li>A suspended battery (2-ended) will align in the north-south direction like a magnet.</li> </ol>	-----	M.B.1
2. Only magnets produce magnetic fields (forces).	M.5.3.2 H.5.3.2	M.B.3 H.B.4
3. Only charges can produce electric fields (forces).	M.5.3.1 H.5.3.4	M.B.4 H.B.2
4. Generating Electricity <ol style="list-style-type: none"> <li>When generating electricity only the magnet can move.</li> <li>Generating electricity requires no work.</li> <li>A magnetic field, rather than a changing magnetic field, causes an electric current.</li> </ol>	M.5.3.2	M.B.5 M.B.5 H.B.2
5. Charges at rest can experience magnetic forces.	M.5.3.1 H.5.3.3	M.B.2 M.5.5 H.B.3

<sup>+</sup> See also conceptual difficulties in Objectives 3.5 (Magnetic and Electrical Interactions and Forces)

## Grades 5-8

### Table of Content Boundaries

PHENOMENA, REPRESENTATIONS AND MODELS, AND TECHNICAL VOCABULARY
Middle School (Grades 5-8)
<p><b>OBSERVATIONS/PHENOMENA</b> (Real World)</p> <ul style="list-style-type: none"> <li><b>Objects:</b> Magnets and simple battery and bulb circuits; simple motors and hand-held generators</li> <li><b>Events:</b> moving magnets and coils of wires; moving magnet near current-carrying wires, building a simple motor; investigating a hand-held generator.</li> </ul> <p><i>Exclusions:</i> Investigating changing electric and magnetic fields is done in grades 9-12.</p>
<p><b>REPRESENTATIONS/MODELS</b></p> <ul style="list-style-type: none"> <li>Visual representations, animations, and computer simulations of motors and generators.</li> </ul> <p><i>Exclusions:</i> Field representations of electromagnetism.</p>
<p><b>TECHNICAL VOCABULARY</b></p> <ul style="list-style-type: none"> <li>generator</li> <li>electromagnetic interaction</li> </ul>

### M.B.1 Connection Between Electric Circuits and Magnetism

Most students think there is a direct connection between electric charges and the magnetic poles – positive charges are attracted to north poles and negative charges to south poles. A suspended battery is like a magnet and will orient in the geographic north-south direction. A magnet can be cut in half to isolate a north pole and a south pole (like charges).

A simple exploration to begin to explore the connection is to place a current-

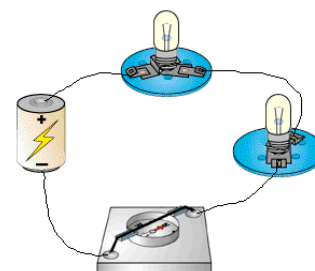

carrying wire above and below a compass.

**M.B.2 and M.B.3 Experimenting with Motors and Analyzing Generators**

There are many ways to investigate the variables that influence the size of the magnetic force on a rotating coil of wire, from very simple qualitative explorations (see diagram of motor at right) to more complex experimental apparatus. Similarly, there are simple ways to investigate how a generator works, from using a hand-held generator to light a bulb to more complex experimental apparatus.

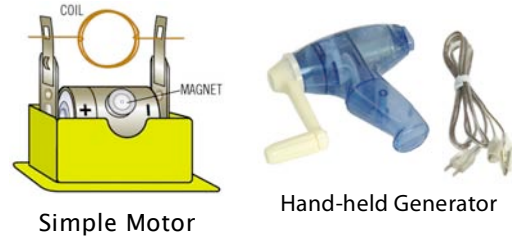

**M.B.5 Example Problem.** In which cases below (a through g) will a current flow in a loop? Explain your reasoning.

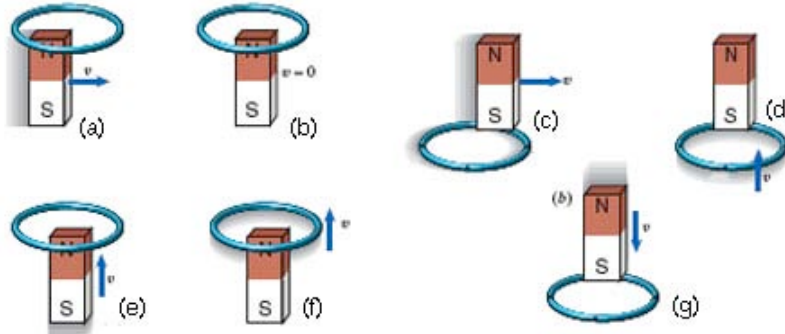

**M.B.4 Experiment**

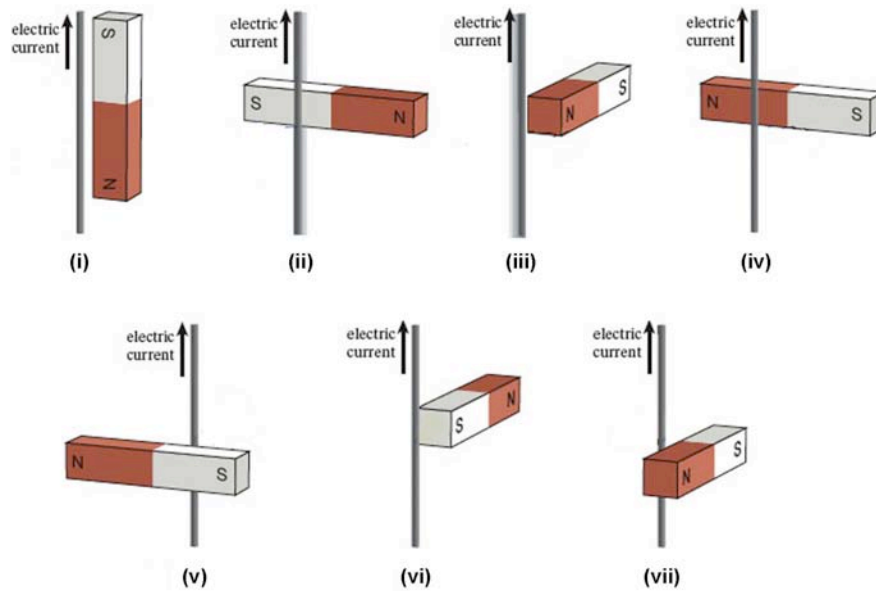

Some different orientations of magnet and current carrying wire are shown above.

## Grades 9-12

### Table of Content Boundaries

PHENOMENA, REPRESENTATIONS AND MODELS, AND TECHNICAL VOCABULARY High School (Grades 9-12)
<p><b>OBSERVATIONS/PHENOMENA</b> (Real World)</p> <ul style="list-style-type: none"> <li>• <b>Objects:</b> Magnets, wire loops with bulb, simple circuits with current-carrying wires, coils and loops of wire; old, broken generators, motors, microphones and speakers.</li> <li>• Magnetic fields around wires with electric current, induced current in wire loops, effect of radio waves on a wire antenna.</li> </ul>
<p><b>REPRESENTATIONS/MODELS</b></p> <ul style="list-style-type: none"> <li>• Visual representations, animations, and computer simulations of Faraday's law, the magnetic field around wires, the effects of changing magnetic and electric fields, generators, motors, microphones, and speakers.</li> </ul> <p><i>Exclusions:</i> Electromagnetic equations</p>
<p><b>TECHNICAL VOCABULARY</b></p> <ul style="list-style-type: none"> <li>• Faraday's Law</li> </ul> <p><i>Exclusions:</i> Oersted's Law, Ampere's Law, and so on.</p>

Underlined words and phrases are defined in the Glossary.

Two good sources of interactive computer simulations and animations in electromagnetism:

1. PhEt Interactive Simulations, University of Colorado, Boulder (<http://phet.colorado.edu/index.php>).
2. Chabay, R. and Sherwood, B., Electric and Magnetic Interactions, (Wiley, New York, 1995) (<http://www4.ncsu.edu/~rwchabay/emimovies/>).



## APPENDIX A

### FIVE PRINCIPLES OF HOW STUDENTS LEARN\*

During the last four decades, scientists have engaged in research that has increased our understanding of human cognition, providing greater insight into how knowledge is organized, how experience shapes understanding, how people monitor their own understanding, how learners differ from one another, and how people acquire expertise. From this emerging body of research, scientists and others have been able to synthesize a number of underlying principles of human learning.† This growing understanding of how people learn has the potential to influence significantly the nature of education and its outcomes.

**Principle 1: Principled Conceptual Knowledge. Learning with understanding is facilitated when new and existing knowledge is structured around the major concepts and principles of the discipline.**

Highly proficient performance in any subject domain requires knowledge that is both accessible and usable. A rich body of content knowledge about a subject area is a necessary component of the ability to think and solve problems in that domain, but knowing many disconnected facts is not enough. Research clearly demonstrates that experts' content knowledge is structured around the major organizing principles and core concepts of the domain, the "big ideas" (e.g., Newton's second law of motion in physics, the concept of evolution in biology, and the concept of limit in mathematics). These big ideas lend coherence to experts' vast knowledge base; help them discern the deep structure of problems; and, on that basis, recognize similarities with previously encountered problems. Research also shows that *experts'* strategies for thinking and solving problems are closely linked to rich, well-organized bodies of knowledge about subject matter. *Their knowledge is connected and organized, and it is "conditionalized" to specify the context in which it is applicable.‡*

*If one conceives of ... [a learning progression] as moving students along a continuum toward greater expertise, then ... [science courses] should have as their goal fostering students' abilities to recognize and structure their growing body of content knowledge according to the most important principles of the discipline. Therefore, curriculum and instruction ... should be designed to develop in learners the ability to see past the surface features of any problem to the deeper, more fundamental principles of the discipline.*

*Curricula that emphasize breadth of coverage and simple recall of facts may hinder students' abilities to organize knowledge effectively because they do not learn anything in depth, and thus are not able to structure what they are learning around the major organizing principles and core concepts of the discipline. Even students who prefer to seek*

understanding are often forced into rote learning by the quantity of information they are asked to absorb.

**Principle 2: Prior Knowledge. Learners use what they already know to construct new understandings.**

When students come to advanced study, they already possess knowledge, skills, beliefs, concepts, conceptions, and misconceptions that can significantly influence how they think about the world, approach new learning, and go about solving unfamiliar problems. People construct meaning for a new idea or process by relating it to ideas or processes they already understand. This prior knowledge can produce mistakes, but it can also produce correct insights. Some of this knowledge base is discipline specific, while some may be related to but not explicitly within a discipline. Research on cognition has shown that successful learning involves linking new knowledge to what is already known. These links can take different forms, such as adding to, modifying, or reorganizing knowledge or skills. How these links are made may vary in different subject areas and among students with varying talents, interests, and abilities. *Learning with understanding, however, involves more than appending new concepts and processes to existing knowledge; it also involves conceptual change and the creation of rich, integrated knowledge structures.*

... Moreover, when prior knowledge is not engaged, students are likely to fail to understand or even to separate knowledge learned in school from their beliefs and observations about the world outside the classroom. ... Effective teaching involves gauging what learners already know about a subject and finding ways to build on that knowledge. *When prior knowledge contains misconceptions, there is a need to reconstruct a whole relevant framework of concepts, not simply to correct the misconception or faulty idea. Effective instruction entails detecting those misconceptions and addressing them, sometimes by challenging them directly."*

**Principle 3: Metacognition. Learning is facilitated through the use of metacognitive strategies that identify, monitor, and regulate cognitive processes.**

To be effective problem solvers (*qualitative or quantitative*) and learners, students need to determine what they already know and what else they need to know in any given situation. *They must consider both factual knowledge – about the task, their goals, and their abilities – and strategic knowledge about how and when to use a specific procedure to solve the problem at hand. In other words, to be effective problem solvers, students must be metacognitive. Empirical studies show that students who are*

metacognitively aware perform better than those who are not.

Metacognition is an important aspect of students' intellectual development that enables them to benefit from instruction and helps them know what to do when things are not going as expected. For example, research demonstrates that students with better-developed metacognitive strategies will abandon an unproductive problem-solving strategy very quickly and substitute a more productive one, whereas students with less effective metacognitive skills will continue to use the same strategy long after it has failed to produce results. The basic metacognitive strategies include (1) connecting new information to former knowledge; (2) selecting thinking strategies deliberately; and (3) planning, monitoring, and evaluating thinking processes.

Experts have highly developed metacognitive skills related to their specific area of expertise. *If students in a subject area are to develop problem-solving strategies consistent with the ways in which experts in the discipline approach problems, one important goal ... should be to help students become more metacognitive. Fortunately, research indicates that students' metacognitive abilities can be developed through explicit instruction ...* It is important to note that the teaching of metacognitive skills is often best accomplished in specific content areas since *the ability to monitor one's understanding is closely tied to the activities and questions that are central to domain-specific knowledge and expertise* (NRC, 2000b).

**Principle 4: Differences Among Learners. Learners have different strategies, approaches, patterns of abilities, and learning styles that are a function of the interaction between their heredity and their prior experiences.**

*... among learners of the same age, there are important differences in cognitive abilities, such as linguistic and spatial aptitudes or the ability to work with symbolic quantities representing properties of the natural world, as well as in emotional, cultural, and motivational characteristics.* Additionally, by the time students reach high school, they have acquired their own preferences regarding how they like to learn and at what pace. Thus, some students will respond favorably to one kind of instruction, whereas others will benefit more from a different approach. Educators need to be sensitive to such differences so that instruction and curricular materials will be suitably matched to students' developing abilities, knowledge base, preferences, and styles.

*Appreciation of differences among learners also has implications for the design of appropriate assessments and evaluations of student learning.* Students with different learning styles need a range of opportunities to demonstrate their knowledge and skills. For example, some students work well under pressure, while the performance of others is significantly diminished by time constraints. Some excel at recalling information, while others are more adept at performance-based tasks. Some express themselves well in writing, while others do not.

Thus using one form of assessment will work to the advantage of some students and to the disadvantage of others.

**Principle 6: Situated Learning. The practices and activities in which people engage while learning shape what is learned.**

Research on the situated nature of cognition indicates that the way people learn a particular domain of knowledge and skills and the context in which they learn it become a fundamental part of what is learned. When students learn, they learn both information and a set of practices, and the two are inextricably related. McLellan (1996, p. 9) states that situated cognition "involves adapting knowledge and thinking skills to solve unique problems ... and is based upon the concept that knowledge is contextually situated and is fundamentally influenced by the activity, context, and culture in which it is used." Learning, like cognition, is shaped by the conventions, tools, and artifacts of the culture and the context in which it is situated.

*Because the practices in which students engage as they acquire new concepts shape what and how the students learn, transfer is made possible to the extent that knowledge and learning are grounded in multiple contexts. Transfer is more difficult when a concept is taught in a limited set of contexts or through a limited set of activities. When concepts are taught only in one context, students are not exposed to the varied practices associated with those concepts. As a result, students often miss seeing the concepts' applicability to solving novel problems encountered in real life, in other classes, or in other disciplines. It is only by encountering the same concept at work in multiple contexts that students can develop a deep understanding of the concept and how it can be used, as well as the ability to transfer what has been learned in one context to others.*

If the goal of education is to allow learners to apply what they learn in real situations, learning must involve applications and take place in the context of authentic activities. J. S. Brown and colleagues (1989, p. 34) define authentic activities as "ordinary practices of a culture"—activities that are similar to what actual practitioners do in real contexts. A. L. Brown and colleagues (1993) offer a somewhat different definition: given that the goal of education is to prepare students to be lifelong learners, activities are authentic if they foster the kinds of thinking that are important for learning in out-of-school settings, whether or not those activities mirror what practitioners do. Regardless of which definition is adopted, the importance of situating learning in authentic activities is clear. Collins (1988) notes the following four specific benefits: (1) students learn about the conditions for applying knowledge, (2) they are more likely to engage in invention and problem solving when learning in novel and diverse situations and settings, (3) they are able to see the implications of their knowledge, and (4) they are supported in structuring knowledge in ways that are appropriate for later use.

*Teachers can engage learners in important practices that can be used in different situations by drawing upon real-world exercises, or exercises that foster problem-solving skills and strategies that are used in real-world situations. ...*

Problem-based and case-based learning are two instructional approaches that create opportunities for students to engage in practices similar to those of experts.

Technology also can be used to bring real-world contexts into the classroom. The committee emphasizes that with all of these approaches, *care must be taken to provide multiple opportunities for students to engage in activities in which the same concept is at work; otherwise learning could become overly contextualized.*

- \* The five learning principles are excerpts from Chapter 6 of *Learning and Understanding: Improving Advanced Study of Mathematics and Science in U.S. High Schools* (National Research Council, 2002). Many of the references in the original have been removed to make the principles easier to read.
- † The research on which these principles are based has been summarized in *How People Learn: Mind, Brain, Experience and School (Expanded Edition)*, National Research Council, 2000.
- ‡ The *blue, italicized portions* are particularly important aspects of the learning principles that were used to develop the learning progressions for the physics college-ready standards.





## APPENDIX B

### RESEARCH USED FOR THE TABLES OF COMMON STUDENT CONCEPTUAL DIFFICULTIES



There are several identical lists of misconceptions or preconceptions available on the Web. Many of these lists can be traced back to a posting of a list by Bill Weiler of U. Illinois via the PHYS-L group 9/1998 (e.g., a list compiled by the Operation Physics Elementary/middle school Physics Education Outreach Project of the American Institute of Physics, available at <http://amasci.com/miscon/opphys.html>). This list was checked and determined that the listed items came from the two books (Driver, Guesne, & Tiberghien, 1985; Driver, 1994). Another list available from the University of Dallas (<http://phys.udallas.edu/C3P/Preconceptions.pdf>) *Helping Students Learn Physics Better—Preconceptions and Misconceptions: A Guide to Enhancing Conceptual Understanding*). This list appears to be compilation of misconceptions from research articles primarily published in *The Physics Teacher* and the *American Journal of Physics*.

These lists were revised based on later research, and newer research added as needed in the *Tables of Common Student Conceptual Difficulties* for each objective. It is impossible to reference all the research literature used to construct each row in the Tables; only research summaries are referenced. The research base includes:

- The cognitive psychology of learning and solving problems (National Research Council, 2000);
- Physics education research on students' conceptual difficulties (undifferentiated concepts and alternative or naïve conceptions, sometimes called preconceptions or misconceptions, from elementary school through first year college (e.g., Driver, Guesne, & Tiberghien, 1985; Driver, 1994; McDermott & Redish, 1999, and AAAS *Benchmarks for Science Literacy Online* at <http://www.project2061.org/publications/bsl/online/index.php?chapter=15>);
- Research on students' difficulties with qualitative and quantitative problem solving in physics (e.g., Maloney, 1994; McDermott & Redish, 1999; Hsu, Brewster, Foster, & Harper, 2004; National Research Council, 2002);
- Research in physics curriculum and instructional strategies based on principles of learning (Abell & Lederman (Eds.), *Handbook of Research in Science Education* (2007); National Research Council, 2002; Arons, 1996; Redish, 2003; Leonard, Dufresne, Gerace, & Mestre (2002).); and
- Recent research indicating that students in grades K-8 can, with appropriate instruction, learn concepts and reasoning skills at a much earlier ages than assumed by the national science standards (e.g., National Research Council, 2006).

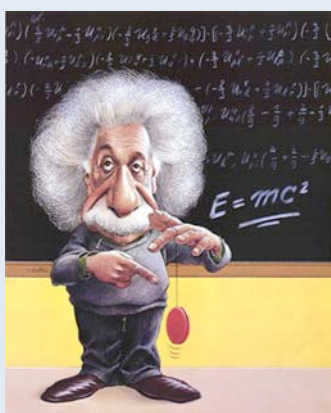



## APPENDIX C

### SUMMARY OF RESEARCH USED TO DEVELOP THE STANDARDS‡

#### 1. Conceptual Difficulties Learning Physics

- a. Students at all grade levels leave current physical science and physics courses with essentially the same conceptual difficulties (including misconceptions, undifferentiated concepts, and over-generalized concepts) as when they entered these courses. For example, after an introductory college physics course, students still confuse position with velocity and velocity with acceleration, just as they did in middle school and high school (e.g., Trowbridge and McDermott, 1980, 1981). Moreover, these misconceptions are directly related to some of the conceptual difficulties students have with Newton's Laws, gravitational, electric charge and magnetic forces and fields, electromagnetic forces, and linear momentum. Another example is that students think that the principle of energy conservation is useless and never use it to solve problems (e.g., Driver and Warrington, 1985, Kautz, Heron, Loverude, & McDermott, 2005). There is sufficient research about physics misconceptions at all levels (35-40 years and over 600 research papers) to identify *common* students conceptual difficulties in every physics content area grades K-12.
- b. Most elementary and middle school science teachers, and many high school physics teachers have essentially the same conceptual difficulties as their students.\*\* (e.g., Cohen, Eylon & Ganiel, 1983;; Galili & Bar, 1992; Trumper, 1996a, 1996b; Palmer, 1997; Heller & Finley, 1992; Bendall, Galili and Goldberg, 1993).
- c. Many of these conceptual difficulties appear to be closely related to curricular and instructional practices.
  - (i) On average, middle school physical science and high school physics teachers spend less than 5% of their classroom time helping students make sense of experimental results, newly presented concepts (from textbook reading, lecture, or lecture-demonstration), or with the application of the concepts beyond recognition and recall (Horizon Research Inc., 2001, 2002a, 2002b). From Middle school to high school to college, too many of essentially the same ideas are taught over and over again much too fast for deep learning to occur.
  - (ii) AAAS's Project 2061 reviewed middle school and high school curriculum materials (including teacher's guides) to determine how currently available learning materials align with national learning goals (Kesidou & Roseman, 2002). They found that the middle and high school programs that they examined were unlikely to result in students developing understandings of key learning goals. Their critique showed that the materials covered many topics at a superficial level, focused on technical vocabulary, failed to consider students' prior knowledge, lacked coherent scientific explanations of real-world phenomena, and provide students with few opportunities to develop explanations of phenomena.
- (iii) *Physics misconceptions are perpetuated through all levels of K-12 education – from textbooks to some State Science Standards and Assessments.* Teachers and textbook writers have the teaching misconception that they should make physics concepts as simple as possible for students by providing short, pithy definitions (e.g., energy is the ability to do work; velocity is speed in a particular direction; and so on). These definitions are either wrong or very misleading. They fail to provide students with the deep conceptual knowledge or problem-solving tools they need to be successful in physics at either the scientific literacy level or the college readiness level.
- d. In 2000, Horizon Research Inc. conducted a national survey (5,728 teachers) of science and mathematics education. They also observed and rated the quality of science and mathematics lessons (Weiss, Pasley, Smith, Banilower, & Heck, 2003). Some results of these studies are outlined below.
  - (i) Middle School (Fulp, 1002). Instruction in physical science (physics and chemistry) at the middle school level varies greatly from state to state. Just over half of the nations middle schools offer general science and integrated science courses; only about 16 percent of the nations middle schools offer a physical science class. [This has changed since 2000. Now the majority of schools offer an 8th grade physical science course.] At most, physics topics are taught for about one-half of an academic year. This averages about 120 hours of instruction (not counting off-task time during science classes, assemblies and other special events, other required curriculum such as health education, and the growing amount of time spent on mandatory state testing). Only about eight percent of middle school science lessons were rated high quality in lesson design and instruction; low ratings are given to 75 percent of lessons. Ratings were weakest for providing adequate time and structure for sense making or wrap-up, teachers' ability to adjust instruction according to student understanding, and teacher's ability to ask questions that enhance student learning.
  - (ii) High School (Banilower, 2002). In high school science, about eleven percent of the lessons were rated high quality in design (with 60 percent rated low quality), and only 14 percent were rated high quality in instruction (with 74 percent

rated low quality). The weakest areas are providing adequate time and structure for sense making and wrap-up, the use of investigative instructional strategies, and the teacher's ability to ask questions that enhance student learning.

- e. Recent research (in the last 10-20 years) indicate that children in grades K-8, are able to learn concepts and reasoning skills at a much earlier ages than assumed by the national standards *with appropriate curriculum and instruction* based on the Principles of Learning (*Taking Science to School: Learning and Teaching Science in Grades K-8*, National Research Council, 2006)

"Children from all backgrounds and all socioeconomic levels show evidence of sophisticated reasoning skills. Although they may lack knowledge and experience, they can and do engage in a wide range of subtle and complex reasoning processes. These processes can form the underpinnings of scientific thinking." (from *Ready, Set, Science: Putting Research to Work in K-8 Science Classrooms*, National Research Council, 2007, page 7).

## 2. Difficulties Learning How to Solve Physics Problems

- a. Expanded Version of the first Principle of Learning, Appendix A. Expert physics problems solvers have a hierarchical organization of physics knowledge that is related to using their knowledge to solve problems. This organization starts with core physics principles or theories in their most general form, for example kinematics (describing the motion of objects), Newton's Laws of Motion, and the principle of energy conservation. These principles are stored in memory *with the conditions under which they can be applied* (e.g., when the object is speeding up, slowing down, and/or changing direction, then it is accelerating; when the acceleration is not constant, then it is more difficult to solve problems; when the sum of forces on an object is zero, then there is no change in velocity of the object; when the system is open, then energy can be transferred into or out of the system). This is followed by specific physics concepts for different applicability conditions, such as definitions of acceleration for different special cases – constant acceleration and average acceleration.
- b. Expert physics problem solvers use the cues in a non-routine problem situation† to decide what general principles to use to approach the problem. They then do an extensive "qualitative analysis" of the problem. This includes deciding the assumptions that need to be made to solve the problem, using their knowledge of the conditions of applicability of concepts and principles to draw representations of the problem (e.g., motion diagrams, force diagrams, energy diagrams), and translating the assumptions and representation(s) of the

problem into mathematical representations. Experts then plan how to solve the problem (e.g., What additional information do I need to solve this problem? Can I extract this knowledge from the problem situation or estimate the unknown information?). Only after this qualitative analysis of the problem do experts use the rules of mathematics (e.g., algebra or calculus) to solve the problem (see references in Maloney, 1994). [Note: Of course, the process is not as linear as implied by this brief description – there are many feedback loops and often more trial and error.]

- c. Physics instruction from middle school through college fails to: (1) provide students with the deep conceptual knowledge they need for the qualitative analysis of problems; (2) promote students' development of hierarchical knowledge of physics principles and concepts, including their conditions of applicability; (3) teach real-world problem solving as a series of decisions; and (4) promote the metacognitive skills students need to make decisions in real-world problem solving. By the time students have finished high school or an introductory college course, their physics knowledge is organized around the surface features of problem situations (e.g., inclined planes, free fall, collisions, and so on) and specific equations that are associated these surface features. Consequently, students do not do qualitative analyses of problems, and even if their knowledge is correct, they cannot solve slightly unfamiliar problems (see references in Maloney, 1994).
- d. Research studies in physics education have shown that students' problem solving skills *and* conceptual knowledge improve when: (1) students are provided with framework (scaffolding) for the decisions that need to be made to solve the problem; (2) instruction focuses explicitly on physics representations -- how to select a system of interest, how to draw motion diagrams, how to draw free-body force diagrams, and so on; and (3) instruction focuses explicitly on the conditions of applicability of the physics concepts and principles (Larkin & Bracket, 1976; van Heuvalin, 1991; Heller, Keith, and Anderson, 1992; Mestre, Dufresne, Gerace, Hardiman, & Touger, 1993; Leonard, Dufresne & Mestre, 1996; Bango & Eylon, 1997) This improvement, however, depends on the types of problems students are asked to solve – only instruction which includes real-world experimental situations and/or context-rich word problems result in an improvement (e.g., van Heuvalin, 1991; Heller & Hollbaugh, 1992; Cummings, Marx, Thornton, & Kuhl, 1999.)

‡ These summary findings are closely related to the Principles of Learning, five of which are described briefly in Appendix A, pages 145 to 147. For the purposes of this document, only example research studies or research summaries have been included as references.

\*\* This is a statistical statement and not a disparaging comment. The statement reflects the fact that teachers are a product of a kindergarten-through-college educational system that teaches too many of the same ideas over and over again much too fast for deep learning to occur. There are notable exceptions and master teachers at all grade levels.

† This includes problems that are "real" to physicists -- problems that they do not initially know how to solve. The problems in introductory college textbooks are not real problems for physicists, and they use automatic "routines" that they know will solve the problem.

## GLOSSARY

The purpose of this glossary is to communicate and clarify how these standards are using terms. Others may use these terms in slightly different ways. The objective in brackets after each term refers to the first objective in which the term was used or defined. Many terms are the same as in the *Science College Board Standards for College Success™*.

**absorption spectra** Refers to the dark lines that appear in the visible spectrum when a cold gas is located between the glowing gas and a prism or diffraction grating (or spectrometer). The pattern of different frequencies is unique for each element. [Objective 1.3]

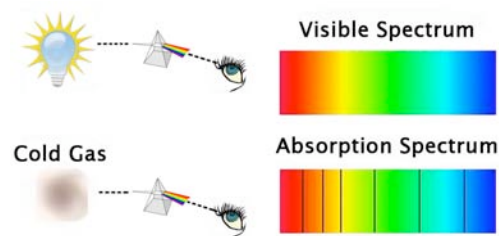

**accuracy** Refers to the bias in data — the difference between the mean of the measurements and the reference value, or “true value.” [Objective 3.1]

**alpha decay** Alpha decay of a radioactive isotope is the release of an alpha particle consisting of two protons and two neutrons (nucleus of a helium atom) from the nucleus. [Objective 2.3]

**amplitude** The distance from the equilibrium line to the crest of a wave. This is often viewed as one-half of the total wavelength. Amplitude is always taken to be positive. [Objective 4.3]

**analogue model** Scientists find it useful to compare a new idea about a system, process, or event with something that is familiar. The thing that is familiar is called an analogue model of the system, process, or event. Analogue models can be physical (e.g., small model car in wind tunnel), verbal, and visual. [Objective 2.1]

**atomic scale** See glossary entry for *domains of magnitude*.

**beta decay** Beta decay of a radioactive isotope is the release of beta particles, which are fast-moving electrons, from the nucleus. [Objective 2.3]

**charging by induction** Charging by induction is a method used to charge a metal object without actually touching the object to any other charged object. A charged object is brought near (but not touching) a metal conductor. A second object that can serve as a source or sink of charge is brought in contact with the metal conductor, then removed. Finally the charged object is removed. The metal conductor is left with a charge opposite that of the original charged object. [Objective 3.5]

**claim** An assertion that is based on evidence or physics knowledge. Claims can be based on the following: natural or human-designed systems and phenomena, observations of the natural world, results of a planned investigation, scientific questions, or answers to a posed question. [Objective 2.1]

**compression (longitudinal) wave** In a compression (longitudinal) wave (e.g., slinky, sound waves), the particles of the medium vibrate back and forth along the same direction as (parallel to) the wave disturbance. Some waves, such as seismic waves, have both compression and transverse components. [Objective 4.3]

**conceptual difficulties** Refers to *common* undifferentiated concepts, alternative or naïve conceptions (sometimes called misconceptions), and mistakes or errors found in the science and physics education research literature. [Introduction to the Standards]

**conservation principle** A quantity is conserved when the total change in the quantity within a system ( $\Delta Q_{\text{system}}$ ) is equal to the total transfer of the quantity into or out of the system ( $Q_{\text{in}} - Q_{\text{out}}$ ). [Objective 2.1]

**cosmic scale** See glossary entry for *domains of magnitude*.

**defined system** See glossary entry for *system of interest*.

**defining characteristics of interactions** Interactions can be classified by the following characteristics:

- (1) The conditions necessary for the interaction to occur (e.g., two objects must be touching, one object must be charged, one object must be moving, one object must be a solid and the other a fluid, etc.);
- (2) The evidence of the interaction – the observed changes; and
- (3) The variables that influence the strength of the interaction (forces, energies, and/or fields). For students in high school, the variables that influence the strength of the interaction are force laws (e.g., empirical relationship for the sliding frictional force, Newton’s universal law of gravitation) and energy and/or field laws (e.g., Ohm’s law). *See also Glossary entries for [interaction](#) and [force law](#).* [Objective 2.1]

**domains of magnitude** In these standards, domains of magnitude refer to three convenient ranges of distance (meters) and time (seconds). The macro (human) domain (distance and time larger than about  $10^{-6}$  and smaller than about  $10^{+10}$ ) corresponds roughly with what can be perceived and measured with either human senses or simple instruments (e.g., optical microscopes and telescopes). The cosmic domain (distance and time larger than about  $10^{+10}$ ) is so great it is almost beyond imagination, and requires instruments or procedures that depend on long chains of reasoning to understand how they work. Similarly, the atomic domain (smaller than  $10^{-6}$  and larger than  $10^{-14}$ ) and subatomic domain (smaller than  $10^{-14}$ ) are tiny beyond imagination, and it requires a great deal of physics knowledge to understand the measurement instruments. [Objective 1.1]

**emission spectra** Refers to the bright lines that appear at different frequencies (energies) of visible light when a prism or diffraction grating (or spectrometer) is placed in front of a glowing gas source. The pattern of energies (frequencies) that appear is unique for each element. [Objective 1.3]

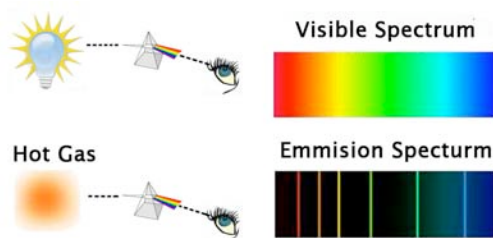

**energy diagram** An energy diagram for a specific event or problem situation represents the type and direction of energy transfers (e.g., thermal energy transfer, electrical energy transfer) within and/or across the boundary of a defined system during a defined time interval. An energy diagram can also include the type and direction of changes (increase, stay the same, decrease) of energy changes within a system (e.g., increase in the kinetic energy of a falling object, decrease in the gravitational potential energy of an Earth-object system). A labeled shape (e.g., box, oval) often represents the objects/subsystems within a system and outside the boundaries of the system, and a labeled arrow often represents energy transfers (see Instructional Guidance for Standard 1 and Standard 4). The example below includes both energy transfers and energy changes for a one-bulb circuit with the defined system of interest the bulb and wires.

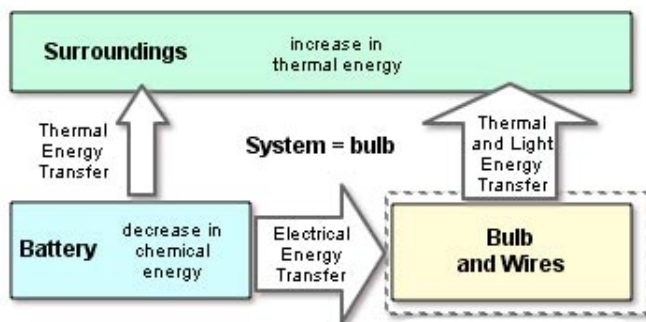

At the high school level, the energy diagram can be a bar graph showing the relative changes in energy within the defined system and the energy transfers into and out of the system. [Objective 2.2, Objectives 4.1 through 4.4] *See also glossary entries for [problem](#) and [system of interest](#).*

**evidence** Data (from investigations, scientific observations, the findings of other scientists, historic reconstruction and/or archived data) that have been represented, analyzed and interpreted in the context of a specific [scientific question](#). Modes of representing data could include, but are not limited to, verbal summaries, diagrams, summary charts and tables, frequency plots, bar graphs (histograms), and scatter plots. These representations, based on accepted physics knowledge and mathematics processes or procedures, are used to interpret the data in terms of properties, trends or patterns. [Objective 2.1]



**explain** See Glossary entry for *explanation*.

**explanation** A scientific explanation includes (1) a claim about natural or designed objects, systems or phenomena; (2) the evidence, which can consist of empirical evidence or observations; and (3) the reasoning that links the claim with the evidence. A scientific explanation can specify causal relationships, generalizations (inductive and analogical), contrasting relationships or proposed models. An explanation also specifies, based on physics knowledge, how or why a natural or designed system has its observed properties, or how an observed phenomenon occurs.

**field diagram** A field diagram shows the strength and direction of a field at different locations around the object producing the field. Field diagrams represent the magnetic, gravitational, electrical, and electromagnetic fields.

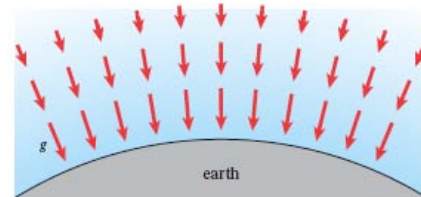

**force diagram** The forces acting on an object can be represented by arrows drawn on an isolated picture of the object. The direction of each arrow shows the direction of the push or the pull. [Objective 3.2]

- For a pushing force, the head of the arrow is placed at the approximate point or surface where the force acts on the system. For a pulling force, the tail of the arrow is placed at the approximate point where the force acts on the system. For long-range forces, the tail of the arrow is placed at the center of the object.
- The length of the arrow represents the (relative) size of the force—longer arrows for larger forces and shorter arrows for weaker forces. If two forces have the same value, the arrows should be equal in length.
- Each force arrow is labeled by a symbol (often a letter) and described by identifying the type of interaction, whether the force is a push or a pull, and the interacting object causing the force.

Example. A student pushes a toy car along a table as the car speeds up



Force Diagram in Direction of Motion

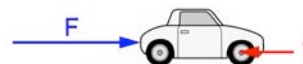

**F** is the contact push applied by my hand on the car

**f** is the frictional push of the rubbing parts in the wheel-axle subsystem on the car

**force law** A force law for an interaction is the empirical approximation or mathematical representation of the variables that determine the magnitude of the forces between the two interacting objects. Force laws are the third defining characteristic of an interaction. See also glossary entry for *defining characteristics of interactions*. [Objective 3.3]

**frequency** The amount of cycles that have been completed in one second. It is measured in hertz (Hz). [Objective 4.3]

**gamma Rays** Gamma decay of a radioactive isotope is the release of radiant energy that is like infrared, visible light, or x-ray, only at a much higher energy. Gamma rays are a type of radiation that results from a redistribution of electric charge within a nucleus. A gamma ray is a high-energy photon. [Objective 2.3]

**interactions** Two objects (which can be a defined quantity of a solid, liquid or gas) interact when they act on or influence each other to cause some effect. The evidence of the interaction is usually the effect — an observed change (e.g., change in motion, shape, mass, temperature, state) of one or both objects. Interaction is a statement of causality in science. In these standards, interactions are described, explained, and predicted with the concepts of forces, energy transfers, linear momentum transfers, and fields. [Objective 1.1]

**investigate** Refers to a variety of ways in which students can gather observations, data and evidence to solve a problem (which can be a laboratory problem, a demonstration, a project, or a word problem rich in context). The observation or idealized data for some problems can sometimes be gathered from computer simulation models. At the middle school level, investigations are often qualitative explorations of phenomena. See also glossary entries for *data*, *evidence*, and *problem*. [Objective 2.1]

**macro (human) scale** See glossary entry for *domains of magnitude*.

**mental model** In these standards, a mental model refers to simplified, idealized set of related ideas from a theory, without the complexities of the full theory. [Objective 1.3] See *glossary entry for theory*.

**methods of energy storage** In these standards, energy can be stored in seven ways.

- Energy can be stored in elastic objects, such as rubber bands or springs. The *elastic energy* of an object changes when it is stretched or compressed. [Objective 4.1]
- Energy can be stored in the motion of objects. Motion (kinetic) energy changes when an object's speed changes. [Objective 4.1]
- Energy can be stored in a system of chemicals. The *chemical energy* of a system changes when the chemicals are allowed to react and new substances are produced. [Objective 4.1]
- Energy can be stored because the object has a temperature and state (solid, liquid, or gas). The *thermal (internal) energy* of an object changes when its temperature or state changes. [Objective 4.1]
- Energy can be stored in the fields of mutually attracting and repelling objects, as in *gravitational field energy*, *electrical field energy*, and *magnetic field energy*. [Objective 5.2]

**Methods of energy transfer** In these standards, energy can be transferred by five methods.

- A *mechanical energy transfer (work)* occurs when an object pushes or pulls the interacting object, which moves while the force acts. [Objective 4.1]
- An *electrical energy transfer* occurs when an energy source (e.g., battery) is connected in a closed circuit to an electrical device (e.g., bulb, motor) and an electrical current flows. [Objective 4.2]
- A *mechanical wave energy transfer* occurs when a vibrating energy source produces a wave disturbance in a material, which travels to a distant receiver without the transfer of the material. [Objective 4.3]
- A *radiant energy transfer* (e.g., light) occurs when a source radiates energy to its surroundings (energy receivers). Radiant energy transfer does not require a material between the source and the receivers. [Objective 4.4]
- A *thermal energy transfer (heat)* occurs when energy is transferred between a warmer object and cooler objects in the surroundings (receivers). Thermal energy transfers usually result in a change in the thermal energy, chemical energy, or kinetic energy of one or both interacting objects. [Objective 4.5]

**momentum diagram (one dimension)** A momentum diagram for a specific event or problem situation includes a vector for the initial momentum of the defined system, a vector for the final momentum, and a vector for the change in momentum of the system. The change in momentum can be found by **vector subtraction**. The momentum diagram often includes a statement about momentum transfer (impulse) by an external force. [Objective 2.2]

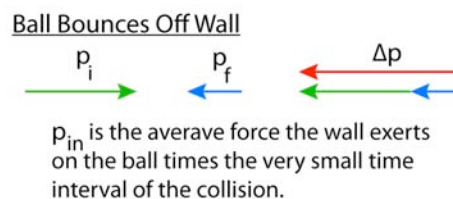

**motion diagram** For middle school, a motion diagram shows the position at each successive clock reading of one or more objects traveling in one direction in a straight line, as shown in the example below. [Objective 3.1]

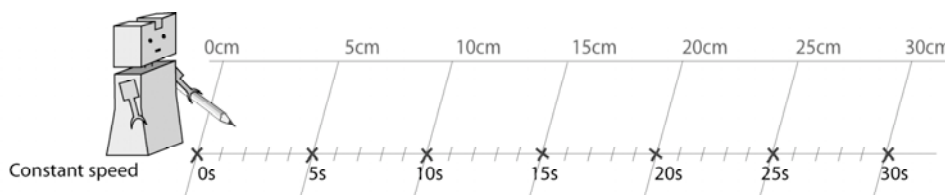

The motion diagram gradually becomes more abstract moving into high school. Dots represent the moving object at specified instants and times along a convenient coordinate axis, the position and velocity are specified at all relevant times at all relevant instants – initial time, final time, and instants when the motion of the object changes (unknowns are labeled with a question mark). Finally, the acceleration is indicated at all relevant times or time intervals. The example below is the motion diagram for a car that accelerates uniformly for 7 seconds then moves with a constant velocity for 4 seconds.



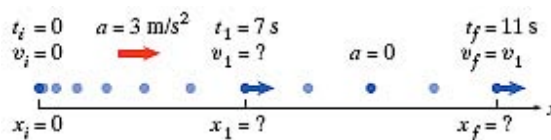

**multistep problem** A problem in which the solver must find several (i.e., two or more) intermediate pieces of information, which must then be used in generating the solution to the entire problem. Multistep problems can be experimental problems, project-based problems, or context-rich word problems.

**particle** In middle school, particle refers to the atoms and molecules of the small-particle model of matter. In high school, particle sometimes refers to subatomic particles. [Objective 1.3] See glossary entry for [subatomic particles](#).

**Michelson-Morley experiment** With a new instrument called an interferometer, Albert A. Michelson and Edward W. Morley (1887) arranged one set of light beams to travel parallel to the direction of the earth's motion through space, another set to travel crosswise to the motion. The experimental result was that the speed of the Earth through the ether was zero. This experiment, like most important new science, was done at the very limit of available techniques. The results were long in dispute. It was only after the invention of lasers that it became easy to show beyond reasonable doubt that the speed of light in a vacuum is invariable -- independent of the speed of the observer.

**photoelectric effect** The photoelectric effect occurs when electrons are released from a metal surface as a result of light shining on that surface. The surprising results were: (a) Red light will not cause the ejection of electrons, no matter what the intensity. (b) A violet light will eject electrons, but their maximum kinetic energies are greater than those for intense light of higher frequencies (higher energy). (c) As the intensity of the incident light is increased, more electrons are emitted, but their maximum kinetic energy does not increase. [Objective 1.4]

**positron** A positron has the same mass as an electron, but is positively charged.

**postulate** A statement that is assumed to be true and is used as the basis of an argument or theory. [Objective 1.4]

**precision** Refers to the spread in a group of measurements. [Objective 3.1]

**problem** A problem is non-routine question to be answered through a hands-on investigation, a demonstration, a project, or by solving word problems rich in context. All problems have two characteristics: (1) the context is real world (i.e., no idealized situations); and (2) some information is observable, measurable, or known. Problems require at least two steps of reasoning, and can be either qualitative or quantitative. See also glossary entries for [qualitative](#) and [quantitative](#). [Objective 1.1]

**qualitative** The reasoning and justification of a description, explanation or prediction requires only comparing the relative sizes or magnitudes of the variable(s) identified in the problem (e.g., increasing, decreasing, or the same; twice as large). [Introduction to Standards]

**quantitative** The reasoning and justification of an explanation or prediction requires the use of equations and/or numbers for the variables identified in the problem. . [Introduction to Standards]

**ray diagram** A diagram showing the path (direction) of a "beam" of light. Three or four short rays are shown to emphasize the concept that light is radiated in all directions from each point of a light source or object (diffuse reflection). The example at right shows the path of three light rays (one from the sun, two from diffuse reflection off surrounding objects) to an apple, then to the eye of an observer. [Objective 4.4]

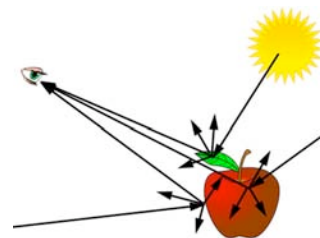

**scientific question** A question that leads to an empirical investigation (collecting and interpreting data to develop an explanation). Types of scientific questions include existence, causal/functional and exploratory questions that involve collecting novel data (NOT testing a hypothesis). [Objective 3.1]

**subatomic particles** Refers to photons, electrons, protons, neutrons, and other particles (e.g., muons, pions, neutrinos). [Objective 1.3]

**subatomic scale** See glossary entry for *domains of magnitude*.

**system of interest** A defined system for a problem. A system is defined by identifying the boundaries of the system and the surrounding objects that could interact with the system. [Objective 1.1] (See also glossary entries for *problem* and *interactions*.)

**theory** A system of scientific explanations or related observations that has been rigorously tested by the scientific community at large. It is often based on numerous verified hypotheses, and as the theory is tested over time, it is revised but is seldom replaced completely. All scientific theories are subject to continuous testing, and when new evidence comes to light that refutes the theory, the theory must then be abandoned or revised to account for this new evidence; otherwise it cannot be tested and therefore cannot be considered scientific. [Objective 1.3]

**totally inelastic collision** An inelastic collision in which the two colliding objects stick together. After the collision, the two objects (stuck together) travel with the same velocity. [Objective 2.2]

**transverse wave** In a transverse wave (e.g., ropes, springs), the particles of material vibrate at right angles to (perpendicular to) the direction the wave disturbance moves through the material. [Objective 4.4]

**two-source interference pattern** When two sources of two- or three-dimensional mechanical waves are vibrating in sync (i.e., in the same direction at the same time), a pattern of locations of constructive and destructive interference is produced. The wavelength and the spacing of the two sources determine the interference pattern. The greater the separation of the sources relative to the wavelength, the larger the number of destructive interference (nodal) curves. [Objectives 1.3 & 4.3]



**vector addition** To add vectors in one dimension, place the tail of the second vector in the sum at the tip of the first vector, then the tail of the third vector in the sum to the tip of the second vector, and so on. The vector representing the sum runs from the tail of the first vector to the tip of the last vector.

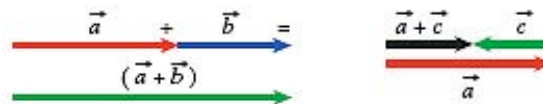

**vector subtraction** To subtract two vectors in one dimension, reverse the direction of the vector being subtracted and add the inverted vector to the vector from which you are subtracting. The vector representing the difference runs from the tail of the first vector to the tip of the second vector. [Objective 3.1]

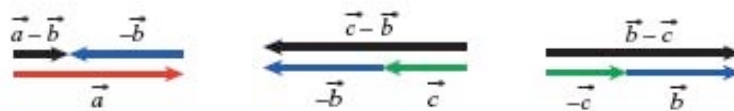

**wavelength** The length (measured in meters) of one complete wave cycle. Thus, after every wavelength, the wave is at a point that is identical to the one where it started — wave motion is periodic. [Objective 4.3]

**weight** The everyday term for the gravitational force (pull) of Earth (or other planet or moon) on objects located on or near Earth's surface (or other planet or moon). [Objective 3.4]



## REFERENCES

- Abell, S. K., & Lederman, N. G. (Eds.). (2007). *Handbook of research in science education*. London: Routledge.
- American Association for the Advancement of Science. (1993). *Benchmarks for science literacy*. New York: Oxford University Press.
- American Association for the Advancement of Science. (2001). *Atlas of science literacy Volume 1*. Washington, D.C.: Author.
- American Association for the Advancement of Science. (2007). *Atlas of science literacy Volume 2*. Washington, D.C.: Author.
- American Association for the Advancement of Science. (2009). The physical setting. In *Benchmarks on-line* (chapter 4). Retrieved April 6, 2010, from <http://www.project2061.org/publications/bsl/online/index.php?chapter=4#chaptoc>
- American Association for the Advancement of Science. (2009). The research base. In *Benchmarks on-line* (chapter 15). Retrieved March 13, 2010, from <http://www.project2061.org/publications/bsl/online/index.php?chapter=15>
- Arons, A. (1977). *The various language: An inquiry approach to the physical sciences*, New York, NY: Wiley
- Arons, A. (1996). *Teaching introductory physics*. Hoboken, N.J.: John Wiley & Sons, Inc.
- Atkin, J.M. and Karplus, R. (1962). Discovery or Invention? in R. G. Fuller (Ed), *A love of discovery: Science Education – the second career of Robert Karplus*, New York, NY: Kluwer Academic/Plenum Publishers (2001: 84-89).
- Bango, E. & Eylon, B. (1997). From problem solving to a knowledge structure: An example from the domain of electromagnetism, *Am. J. Phys.* **65**, 726-736.
- Banilower, E. R., (2002). 2000 National survey of science and mathematics education: Status of high school physics teaching, NC: Horizon Research Inc, <http://2000survey.horizon-research.com/reports/>
- Bendall, S., Galili, I., and Goldberg, F. (1993). Prospective elementary school teachers' prior knowledge about light," *J. Res. Sci. Teach.* **30**:9, 1169-1187.
- Brown, A.L., Ash, D., Rutherford, M., Nakagawa, K., Gordon, A., & Campione, J.C. (1993). Distributed expertise in the classroom. In G. Salomon (Eds.), *Distributed Cognitions* (pp. 188-228). New York: Cambridge University Press.
- Brown, J. S., Collins, A., & Duguid, P. (1989). Situated Cognition and the Culture of Learning. *Educational Researcher*, **18**(1), 32-42.
- Cohen, R., Eylon, B., and Ganiel, U. (1983). Potential difference and current in simple electric circuits: A study of students' concepts, *Am. J. Phys.* **51**, 407-412.
- College Board (2006), *College Board Standards for College Success™: Mathematics and Statistics*, New York, NY: The College Board.
- College Board (2009), *Science: College Board Standards for College Success™*, New York, NY: The College Board.
- Collins, A. (1988). *Cognitive apprenticeship and instructional technology*. (Technical Report No. 6899). BBN Labs Inc., Cambridge, MA.
- Donati, O., Missiroli, G.F., and Pozzi, G. (1973). An Experiment on Electron Interference, *American Journal of Physics*, **41**, 639
- Driver, R. & Warrington, L. (1985). Students' use of the principle of energy conservation in problem situations, *Physics Education*. **20**: 171-176
- Driver, R., Guesne, E., & Tiberghien, A. (Eds.). (1985). *Children's ideas in science*. Philadelphia: Open University Press.
- Driver, R., Squires, A., Rushworth, P., & Wood-Robinson, V. (1994). *Making sense of secondary science: Research into children's ideas*. London: Routledge.
- Feynman, R. (1985), *QED: The strange theory of light and matter*, Princeton University Press, ISBN 0691024170 .
- Fulp, S.L. (2002). 2000 National survey of science and mathematics education: Status of middle school science teaching, NC: Horizon Research Inc, <http://2000survey.horizon-research.com/reports/>

- Galili, I. and V. Bar, V. (1992). Motion implies force: Where to expect vestiges of the misconception? *Int. J. Sci. Educ.* **14**:1, 63-81 (1992).
- Goldberg, F., Bendall, S., Heller, P., & Poel, R. (2006). *InterActions in Physical Science*. Armonk, NY: It's About Time, Herff Jones Education Division.
- Haber-Shaim, Gardner, Dodge, Shore, & Walter (1991). Physical Science (PSSC),
- Heller, P. & Finley, F. (1992). Variable uses of alternative conceptions: A case study in current electricity, *J. Res. Sci. Teach.* **29**(3), 259-275
- Heller, P. & Hollabaugh, M. (1992). Teaching problem solving through cooperative grouping. Part 2: Designing problems and structuring groups. *Am. J. Phys.* **60**(7), 637-645.
- Heller, P., Keith, R., & Anderson, S. (1992). Teaching problem solving through cooperative grouping. Part 1: Groups versus individual problem solving. *Am. J. Phys.* **60**(7), 627-636.
- Hsu, L., Brewster, E., Foster, T. M., & Harper, K. A. (2004), Resource Letter RPS-1: Research in problem solving, *Am. J. Phys.*, **72**(9), 1147.
- Jewett Jr., J. W. (2008a). Energy and the confused student I: Work, *The Phys. Teach.* **46**: 1.
- Jewett Jr., J. W. (2008b). Energy and the confused student II: Systems, *The Phys. Teach.* **46**: 81.
- Jewett Jr., J. W. (2008c). Energy and the confused student III: Language, *The Phys. Teach.* **46**: 149.
- Jewett Jr., J. W. (2008d). Energy and the confused student IV: A global approach to energy, *The Phys. Teach.* **46**: 210.
- Karplus, R. (2003). *Introductory physics: A model approach*, F. Braunshwig (Ed.), Buzzards Bay, MA: Captain's Engineering Services.
- Kautz, C.H., Heron, P.R.L., Loverude, M.E., and McDermott, L.C. (2005) Student understanding of the ideal gas law, Part I: A macroscopic perspective, *Am. J. Phys.* **73**(11) 1055-1063.
- Kennedy, R. J.; Thorndike, E. M. (1932). Experimental establishment of the relativity of time. *Physical Review* **42** (3): 400–418. [doi:10.1103/PhysRev.42.400](https://doi.org/10.1103/PhysRev.42.400).
- Kesidou, S., & Roseman, J. (2002), How well do middle school science programs measure up? Findings from Project 2061's curriculum review. *J. Res. Sci. Teach.* **39**(6), 522–549.
- Leonard, W.J., Dufresne, R. J., Gerace, W. J. & Mestre, J. P. (2002). *Minds-On Physics*, Kendall Hunt: NJ.
- Leonard, W.J., Dufresne, R.J. & Mestre, J.P. (1996). Using qualitative problem-solving strategies to highlight the role of conceptual knowledge in solving problems. *Am. J. Phys.* **64**, 1495-1503.
- Maloney, D. P. (1994). Research on problem solving: Physics. In D. L. Gabel (Ed.), *Handbook of research on science teaching and learning* (pp. 327-356), Macmillan, NY.
- Mazur, E. (2005), *Physics*, trial test version of textbook for introductory physics, Prentice Hall.
- McDermott, L. C. & Redish, E. F. (1999). Resource letter on physics education research, *Am. J. Phys.*, **67**(9):755.
- McLellan, H. (1996). Situated learning: Multiple perspectives. In H. McLellan (Ed.), *Situated learning perspectives* (pp. 5-17). Englewood Cliffs, NJ: Educational Technology Publications.
- Mestre, J. P., Dufresne, R. J., Gerace, W. J., Hardiman, P. T., & Touger, J. S. (1993). Promoting skilled problem-solving behavior among beginning physics students. *J. Res. Sci. Teach.* **30**(3), 303-317.
- Michelson A. A. & Morley E. W. (1887). On the relative motion of the earth and the luminiferous ether. *American Journal of Science* **34**: 333–345.
- Millar, R. (2005). *Teaching about energy*, England: University of York, Department of Educational Studies Research Paper 2005/11, ISBN: 1 85342 626 1.
- Morse, R. A. (1992). Teaching about electrostatics, Washington DC: AAPT Press

- National Research Council (2006). *Taking science to school: Learning and teaching in grades K-8*. Washington, DC: National Academy Press.
- National Research Council (2007). *Ready, set, science: Putting research to work in K-8 science classrooms*, Washington, DC: National Academy Press
- National Research Council. (1996). *National science education standards*. Washington, D.C.: The National Academies Press.
- National Research Council. (1999). *How people learn: Brain, mind, experience, and school*. J. Bransford, A. L. Brown, & R. R. Cocking (Eds.). Washington, D.C.: The National Academies Press.
- National Research Council. (2002). *Learning and understanding: Improving advanced study of mathematics and science in U.S. high schools*. Washington, D.C.: The National Academies Press.
- National Research Council. (2005). *How students learn: Science in the classroom*. M. S. Donovan & J. Bransford (Eds). Washington, D.C.: The National Academies Press.
- Pacific Research Institute (1999). *Developing and Implementing Standards*. Retrieved from [http://www.pacificresearch.org/pu/sab/educat/ac\\_standards/main.html](http://www.pacificresearch.org/pu/sab/educat/ac_standards/main.html)
- Palmer, D. (1997). The effect of context on students' reasoning about forces, *Int. J. Sci. Educ.* **19**:6, 681-696
- Parker, S. (1972). A Single-Photon Double-Slit Interference -- A Demonstration, *Am J Phys* **40**, 1003-1006
- Purcel E, M. (1984). *Electricity and magnetism*, in Berkeley Physics Course. 2nd ed. Vol. 2, NY: McGraw-Hill
- Redish, E. F. (2003), *Teaching physics with the physics suite*, New York: Wiley (pre-publication available online at <http://www2.physics.umd.edu/~redish/Book/>).
- Smith, C. L., Wiser, M., Anderson, C. W., & Krajcik, J. (2006). Implications of research on children's learning for standards and assessment: A proposed learning progression for matter and the atomic molecular theory. Focus Article. *Measurement: Interdisciplinary Research and Perspectives*, **14**, 1-98.
- Swackhamer, G. (2010). *Cognitive Resources for Understanding Energy* (pages 22-39). Retrieved April 25, 2008 from (<http://modeling.asu.edu/Projects-Resources.html>).
- Thomas B. Fordham Institute (2005). *The State of State Science Standards - 2005*. Thomas B. Fordham Institute. Retrieved from <http://www.edexcellence.net/doc/Science%20Standards.FinalFinal.pdf>
- Trumper, R. (1996a). A cross-college age study about physics students' conceptions of force in pre-service training for high school teachers, *Phys. Educ.* **31**:4, 227-236
- Trumper, R. (1996b). A survey of Israeli physics students' conceptions of energy in pre-service training for high school teachers, *Research in Science & Technological Education*, **14**(2),179-182.
- van Heuveln, A. (1991). Overview Case Study Physics, *Am. J. Phys.* **59**(10), 898-905.
- Van Heuveln, A. (1999). *ActivPhysics*, Addison Wesley: NY.
- Walborn S.P., Terra Cunha M.O., Padua S., and C. H. Monken, C.H. (2002), Entanglements, *Physical Review A*, (**65**, 033818)
- Weiss. I. R., Pasley. J. D., Smith, P. S., Banilower, E. R., and Heck, D. J. (2003). Looking inside the classroom: A study of K-12 mathematics and Science Education in the United States, NC: Horizon Research Inc, <http://www.horizon-research.com/insidetheclassroom/reports/looking/>
- Westphal, P. (2010). *A Financial Asset Model of Energy*. Retrieved June 12, 2009 from (<http://modeling.asu.edu/Projects-Resources.html>).

